



HARVEST BELTS®



CATALOGUE 2010

I edition

HARVEST BELTS®

Catalogue 2010
1st edition



HARVEST BELTS®



CATALOGUE 2010

I edition



Case Intl. Harvester 715.....	5
Case Intl. Harvester 915.....	6
Case Intl. Harvester 1400NA.....	7
Case Intl. Harvester 1400NA -1440E.....	8
Case Intl. Harvester 1460NA.....	9
Case Intl. Harvester 1460NA - 1460E.....	10
Case Intl. Harvester 1480.....	11
Case Intl. Harvester 1480NA.....	12
Case Intl. Harvester 1620.....	13
Case Intl. Harvester 1640.....	14
Case Intl. Harvester 1640 Engin.....	15
Case Intl. Harvester 1660.....	16
Case Intl. Harvester 1660 Engin.....	17
Case Intl. Harvester 1680 Engin.....	19
Claas Columbus.....	20
Claas Commandor 114.....	21
Claas Commandor 115.....	22
Claas Commandor 116 - 228.....	23
Claas Commandor 116 - 228.....	24
Claas Consul.....	25
Claas Dominator 48.....	26
Claas Dominator 56-66.....	27
Claas Dominator 68.....	28
Claas Dominator 76.....	29
Claas Dominator 80 - 85.....	30
Claas Dominator 86.....	31
Claas Dominator 88 VX.....	32
Claas Dominator 96.....	33
Claas Dominator 98 VX.....	34
Claas Dominator 98.....	35
Claas Dominator 100 - 105.....	36
Claas Dominator 106.....	37
Claas Dominator 108 - 118 Hydr.....	38
Claas Dominator 108 - 118 Hydr.....	39
Claas Dominator 108 - 118 Mech.....	40
Claas Dominator 108 VX.....	41
Claas Dominator 112.....	42
Claas Dominator 114.....	43
Claas Dominator 115.....	44
Claas Dominator 116.....	45
Claas Dominator 204 - 203 MEGA.....	46
Claas Dominator 218 - 208 MEGA.....	47
Claas Europa.....	48
Claas Jaguar 60.....	49
Claas Jaguar 70 SF.....	50
Claas Jaguar 75 - 71.....	51
Claas Jaguar 682S - SL.....	52
Claas Jaguar 685 - 690.....	53
Claas Jaguar 695 - 685 SL.....	54
Claas Jaguar 840 - 820.....	55
Claas Lexion 410 - 405.....	56
Claas Lexion 430 - 415.....	57
Claas Lexion 460 - 440.....	58
Claas Lexion 480.....	59
Claas Matador - STD - Gigant.....	60
Claas Medion 320 - 310.....	61
Claas Medion 340.....	62
Claas Mercator 50 - 60.....	63
Claas Mercator 570 - 75.....	64
Claas Mercator.....	65
Claas Mercur.....	66
Claas Protector.....	67
Claas Senator.....	68
Deutz Fahr 3630 - M 3640.....	69
Deutz Fahr M 2385.....	70
Deutz Fahr M 2480 - M 2780.....	71
Deutz Fahr M 2480 - M 2780.....	72
Deutz Fahr M 3280.....	73
Deutz Fahr M 3570 - M 3578.....	74
Deutz Fahr Topliner 4060 - 4065.....	75
Deutz Fahr Topliner 4070.....	76
Fortschritt E 514.....	77
Fortschritt E 516 - E 517.....	78
Fortschritt E 524 - E 525.....	79
Fortschritt E 527.....	80
John Deere 1032 - 1042 - 1052.....	81
John Deere 1055.....	82
John Deere 1065 - 1068.....	83
John Deere 1169 - 1169 HYDRO 4.....	84
John Deere 1170.....	85
John Deere 1174 - 1174 HYDRO 4.....	86
John Deere 1188 - 1188 HYDRO 4.....	87
John Deere 2054 - 2056 - 2058.....	88
John Deere 2054 - 2056 - 2058.....	89

John Deere 2064 - 2066.....	90
John Deere 2254 - 2256 - 2258.....	91
John Deere 2264 - 2266.....	92
John Deere 4420.....	93
John Deere 6600 SIDEHILL.....	94
John Deere 6600.....	95
John Deere 6620.....	96
John Deere 6620.....	97
John Deere 7700.....	98
John Deere 7700.....	99
John Deere 8820.....	100
John Deere 9400.....	101
John Deere 9500.....	102
John Deere 9600.....	103
John Deere 9650 STS - 9750 STS.....	104
John Deere CTS 2 (EUROPE).....	105
John Deere CTS (EUROPE).....	106
John Deere CTS (USA).....	107
Laverda 3200.....	108
Laverda 3300 AL.....	109
Laverda 3300.....	110
Laverda 3350 (EX AL 112).....	111
Laverda 3350 (EXM 112).....	112
Laverda 3450 (EX AL 132).....	113
Laverda 3700.....	114
Laverda 3900.....	115
Laverda M 84.....	116
Laverda M 90.....	117
Massey Ferguson 510 - 515.....	118
Massey Ferguson 540.....	119
Massey Ferguson 550.....	120
Massey Ferguson 760 - 765.....	121
Massey Ferguson 760 - 765.....	122
Massey Ferguson 860 - 865.....	123
Massey Ferguson 8560.....	124
Massey Ferguson 8570.....	125
Massey Ferguson 8590.....	126
Massey Ferguson 9720.....	127
Massey Ferguson Swather 885.....	128
New Holland 1520.....	129
New Holland 1530.....	130
New Holland 1540 - 1540 AL.....	131
New Holland 1545.....	132
New Holland 1550.....	133
New Holland 8030.....	134
New Holland 8040.....	135
New Holland 8050.....	136
New Holland 8055.....	137
New Holland 8060.....	138
New Holland 8070.....	139
New Holland 8080.....	140
New Holland 9630 - 9640 - 9645.....	141
New Holland FX 300 -FX 375.....	142
New Holland M 80.....	143
New Holland M 89.....	144
New Holland M 103.....	145
New Holland M 122.....	146
New Holland M 133 - M 135.....	147
New Holland Swather 1112 - 1114.....	148
New Holland Swather 2450 - 2550.....	149
New Holland T 75 - TR 85.....	150
New Holland TC-52 TC-54 TC-56.....	151
New Holland TC-57.....	152
New Holland TF-42 - TF-44.....	153
New Holland TR-75.....	154
New Holland TR-85.....	155
New Holland TR-86.....	156
New Holland TR-95.....	157
New Holland TR-96.....	158
New Holland TR-70.....	159
New Holland TR-97.....	160
New Holland TR-98.....	161
New Holland TX-30.....	162
New Holland TX-32.....	163
New Holland TX-34.....	164
New Holland TX-36.....	165
New Holland TX 62-TX 63-TX 64-TX 65-TX 66-TX 67-TX 68-TX.....	166
New Holland TX 62-TX 63-TX 64-TX 65-TX 66-TX 67-TX 68-TX.....	167

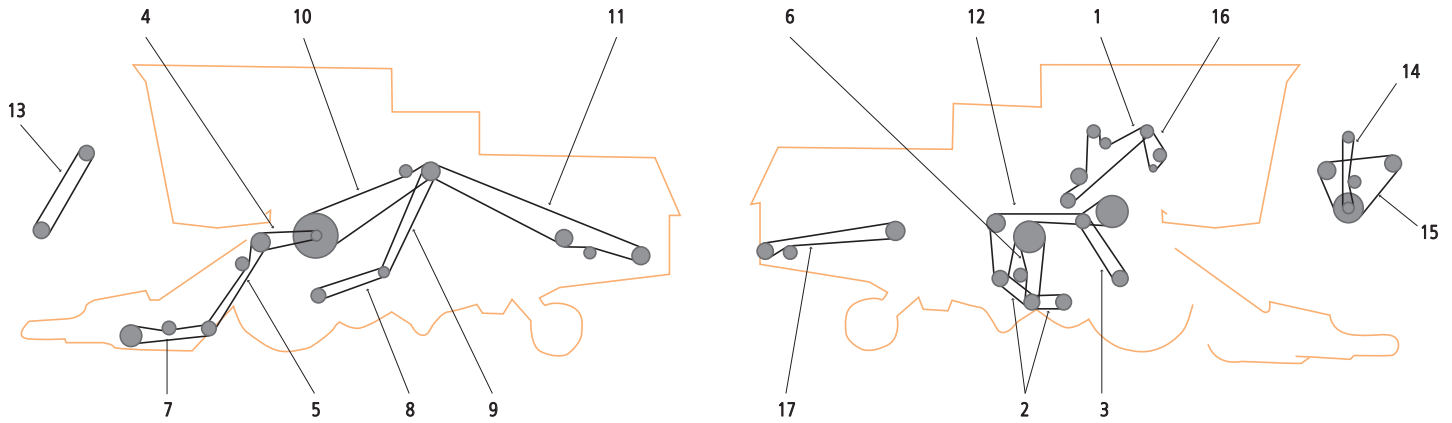

ITEM	APPLICATION	QUANTITY OF V-BELTS IN DRIVE	OE PART NUMBER	COMMENT
0	FAN. WATER PUMP AND ALTERNATOR IH D310	1	3955539R1	X
0	COMPRESSOR. AC	1	936331R1	X
1	GRAIN TANK EXT WITH RAISED LEVELLING AUGER	1	150433C1	
1	ELEVATOR DRIVE. W/O RAISED LEVELLING AUGER	1	937928R1	
1	ELEVATOR DRIVE. WITH RAISED LEVELLING AUGER	1	937929R1	
2	FAN DRIVE. MATCHED PAIR	1	170954C11	X
2	FAN DRIVE	1	178936C1	X
3	SHAKER SHAFT DRIVE	1	188716C1	
4	FEEDER DRIVE. REGULAR	1	937932R1	
5	FEEDER JACKSHAFT DRIVE	1	176566C1	X
5	FEEDER JACKSHAFT DRIVE X2 BELT RICE ONLY	1	176577C1	
5	FEEDER JACKSHAFT DRIVE. RICE	1	176657C1	X
6	UNLOADER DRIVE. BELT DRIVE	1	559064R1	
6	UNLOADER HYDROSTATIC DRIVE	1	1656676C1	
7	AUGER AND KNIFE DRIVE (112)	1	191305C1	
7	AUGER AND KNIFE DRIVE (150)	1	559064R1	
7	AUGER AND KNIFE DRIVE (102)	1	178019C1	
8	PROPULSION DRIVE (BELT DRIVE)	1	173110C1	X
9	PROPULSION JACKSHAFT DRIVE	1	150436C2	X
10	SEPARATOR DRIVE	1	171226C1	
11	STRAW CHOPPER DRIVE	1	174614C2	
12	STRAW WALKER AND FAN JACKSHAFT	1	170948C1	X
13	UNLOADER JACKSHAFT DRIVE. HYDROSTAT	1	175545C1	
13	UNLOADER JACKSHAFT DRIVE	1	179317C2	
14	VARIABLE SPEED CYLINDER DRIVE (PRIMARY)	1	171101C2	
15	CYLINDER DRIVE. VARIABLE SPEED	1	171130C1	X
16	TAILINGS AUGER DRIVE	1	627297R1	X
17	STRAW SPREADER	1	589622R1	

X - not in standard offer

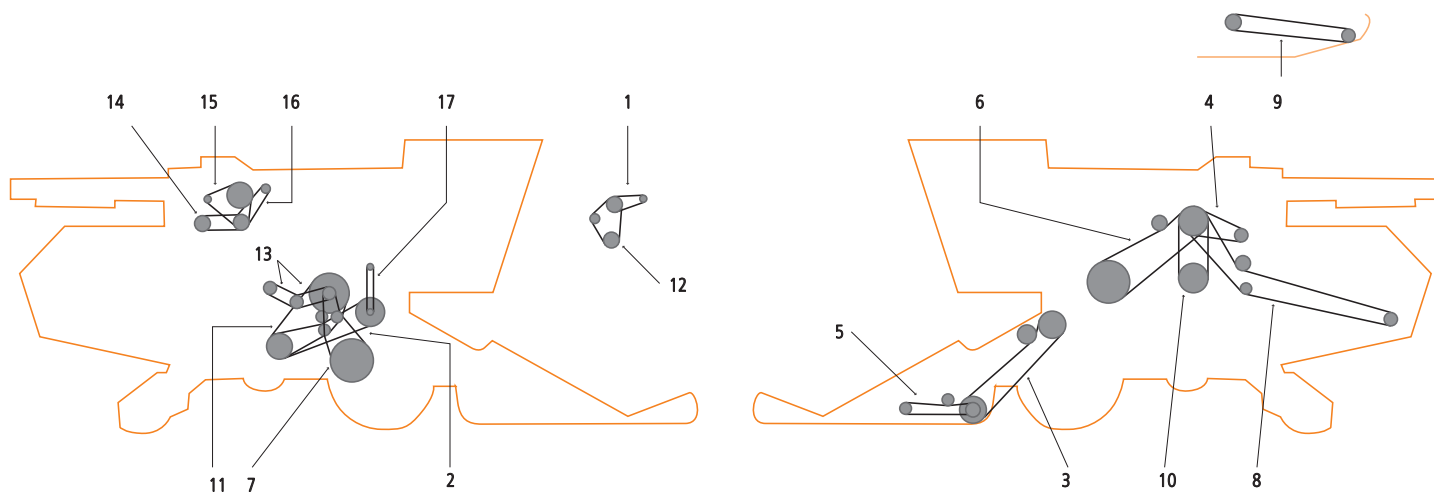

ITEM	APPLICATION	QUANTITY OF V-BELTS IN DRIVE	OE PART NUMBER	COMMENT
0	STRAW CHOPPER JACKSHAFT DRIVE	1	160871C1	
0	ROTARY AIR SCREEN DRIVE	1	168725C1	
0	ROTARY AIR SCREEN DRIVE	1	172360C1	
0	ROTARY AIR SCREEN DRIVE	1	38331K	
0	FEEDER. FAST SPEED FOR BOLT ATT. FEEDER	1	633728R2	
2	CYLINDER DRIVE	1	174509C1	
3	FEEDER JACKSHAFT DRIVE	1	176565C1	
3	FEEDER JACKSHAFT DRIVE	1	176566C1	X
3	FEEDER JACKSHAFT DRIVE	1	176567C1	
3	FEEDER JACKSHAFT DRIVE	1	176576C1	
3	FEEDER JACKSHAFT DRIVE	1	176577C1	
4	HYDRAULIC REEL PUMP DRIVE. DIESEL	1	179007C1	
5	KNIFE DRIVE	1	178019C1	
6	SEPARATOR DRIVE. GAS	1	166598C2	
6	SEPARATOR DRIVE. DIESEL	1	168665C2	
7	SHAKER SHAFT DRIVE. 265 RPM	1	564494R2	
7	SHAKER SHAFT DRIVE. 280 RPM	1	632702R1	
8	STRAW CHOPPER DRIVE	1	160870C1	
8	STRAW CHOPPER DRIVE	1	174642C1	
8	STRAW CHOPPER DRIVE	1	177499C1	
9	STRAW SPREADER DRIVE	1	196371C1	
9	STRAW SPREADER DRIVE	1	161821C1	
10	UNLOADER JACKSHAFT DRIVE	1	160173C1	
11	CYLINDER DRIVE. VARIABLE	1	164006C1	X
12	FAN. WATER PUMP. GENERATOR (DIESEL ONLY)	1	528419R91	X
12	FAN. WATER PUMP. GENERATOR W/414 ENGINE	1	537072R92	X
13	SEPARATOR FAN DRIVE	1	164999C92	X
15	FAN. ALTERNATOR. WATER PUMP (W/AC)	1	402253R91	
16	GOVERNOR BELT	1	532031R2	
17	CYLINDER SPEED DRIVE	1	167099C	X

X - not in standard offer

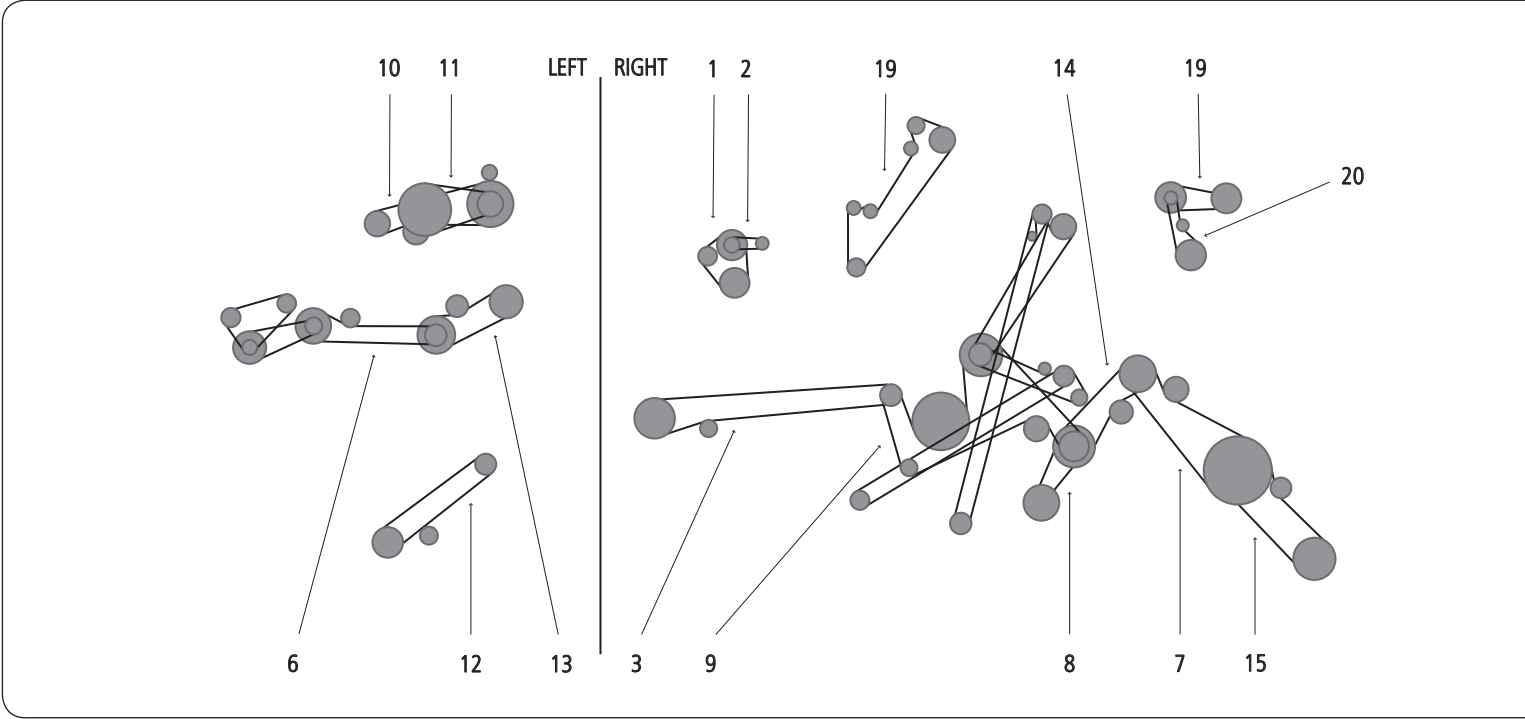

ITEM	APPLICATION	QUANTITY OF V-BELTS IN DRIVE	OE PART NUMBER	COMMENT
1	WATER PUMP, FAN ALTERNATOR	1	537072R92	X
2	AIR CONDITIONING COMPRESSOR	1	874097C1	X
3	STRAW SPREADER DRIVE	1	153359C1	
6	UNLOADER AUGER DRIVE	1	191290C1	
7	FEEDER DRIVE	1	192738C1	
8	CLEANING FAN DRIVE	1	195396C2	
9	ELEVATOR DRIVE UNIT	1	186509C2	X
9	ELEVATOR DRIVE UNIT	1	192360C1	
10	SEPARATOR DRIVE	1	191241C3	
11	ROTOR VARIATOR DRIVE	1	244420A1	X
12	REEL DRIVE PUMP	1	197414C2	
12	REEL DRIVE PUMP	1	1315315C1	X
13	AUXILIARY PUMP DRIVE	1	191288C3	
14	FAN JACKSHAFT DRIVE	1	191305C1	
15	FEEDER JACKSHAFT DRIVE	1	1313095C2	
15	FEEDER JACKSHAFT DRIVE	1	1313097C3	
19	FAN JACKSHAFT	1	181359C1	X
20	SLOW SPEED FAN JACKSHAFT	1	610521R1	

X - not in standard offer

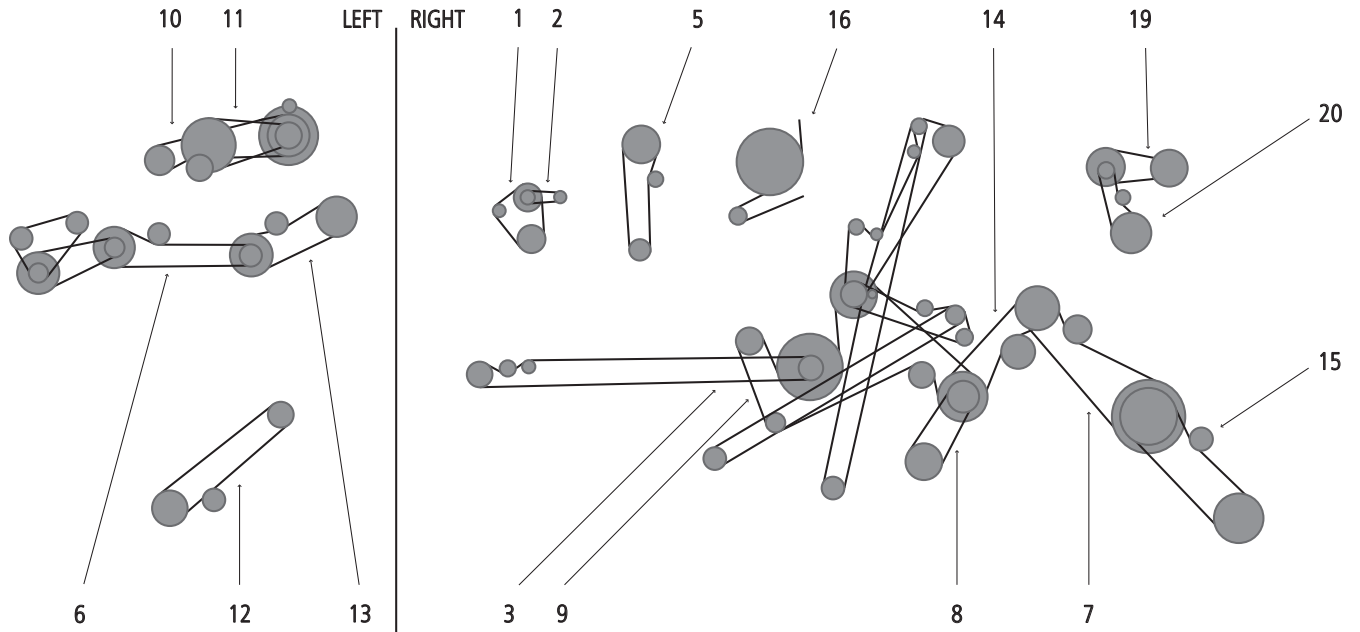

ITEM	APPLICATION	QUANTITY OF V-BELTS IN DRIVE	OE PART NUMBER	COMMENT
1	WATER PUMP, FAN ALTERNATOR	1	537072R92	X
2	AIR CONDITIONING COMPRESSOR	1	874097C1	X
3	STRAW SPREADER DRIVE	1	196371C1	
5	STRAW CHOPPER DRIVE	1	181012C1	
6	UNLOADER AUGER DRIVE	1	191290C1	
7	FEEDER DRIVE	1	192738C1	
8	CLEANING FAN DRIVE	1	195396C2	
9	ELEVATOR DRIVE UNIT	1	186509C2	X
10	SEPARATOR DRIVE	1	191241C3	
11	ROTOR VARIATOR DRIVE	1	244420A1	X
12	REEL DRIVE PUMP WITHOUT ROCK TRAP	1	197414C2	
12	REEL DRIVE PUMP WITH ROCK TRAP	1	1315315C1	X
12	REEL DRIVE PUMP WITHOUT ROCK TRAP	1	197411C1	
13	AUXILIARY PUMP DRIVE	1	191288C3	
14	FAN JACKSHAFT DRIVE	1	191305C1	
15	FEEDER JACKSHAFT DRIVE	1	1313095C2	
15	FEEDER JACKSHAFT DRIVE	1	1313097C3	
16	CLEANING UNIT DRIVE WITH STRAW CHOPPER	1	181055C1	
19	FAN JACKSHAFT	1	181359C1	X
20	SLOW SPEED FAN JACKSHAFT	1	610521R1	

X - not in standard offer

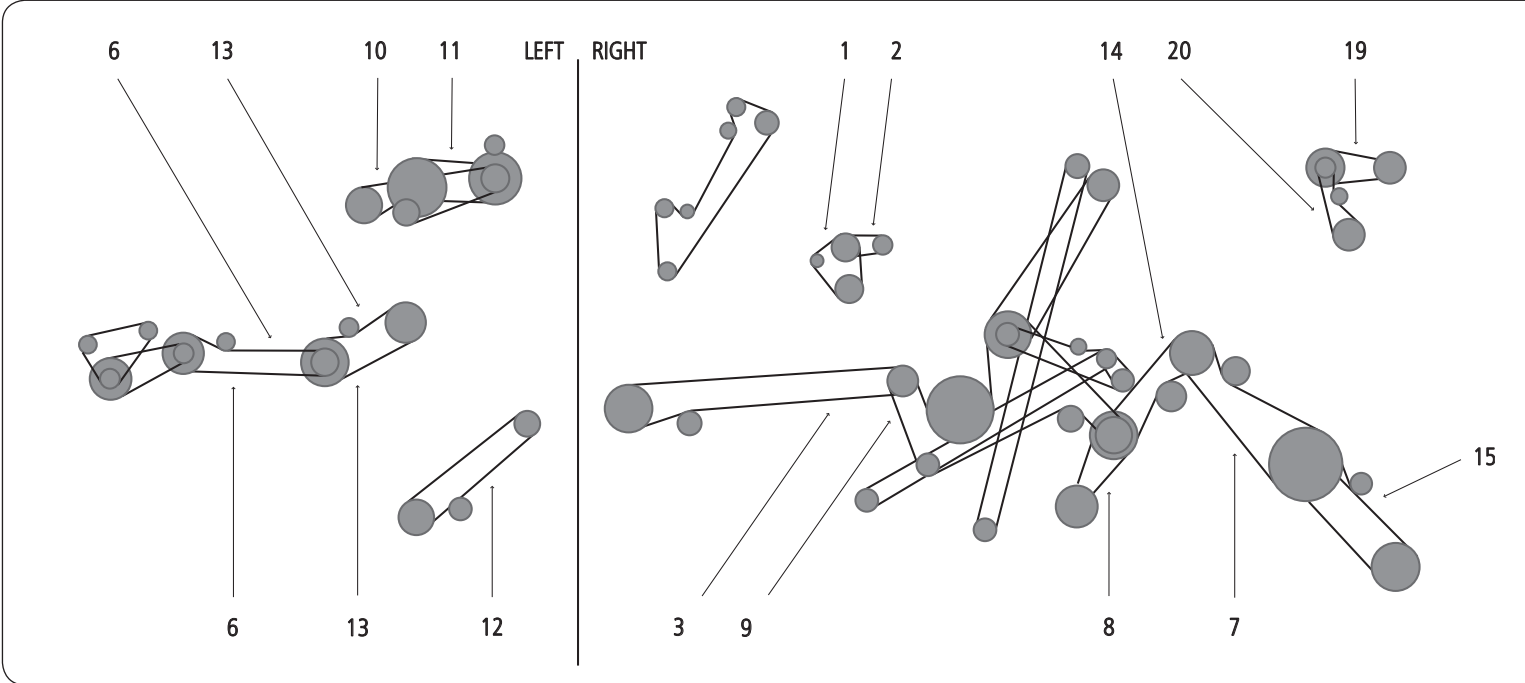

ITEM	APPLICATION	QUANTITY OF V-BELTS IN DRIVE	OE PART NUMBER	COMMENT
1	WATER PUMP. FAN ALTERNATOR	1	537072R92	X
2	AIR CONDITIONING COMPRESSOR	1	874097C1	X
3	STRAW SPREADER DRIVE	1	153359C1	
6	UNLOADER AUGER DRIVE	1	191290C1	
7	FEEDER DRIVE	1	192738C1	
8	CLEANING FAN DRIVE	1	195396C2	
9	ELEVATOR DRIVE UNIT	1	186509C2	X
9	ELEVATOR DRIVE UNIT	1	192360C1	
10	SEPARATOR DRIVE	1	191241C3	
11	ROTOR VARIATOR DRIVE	1	244420A1	X
12	REEL DRIVE PUMP WITHOUT ROCK TRAP	1	197414C2	
12	REEL DRIVE PUMP WITH ROCK TRAP	1	1315315C1	X
13	AUXILIARY PUMP DRIVE	1	191288C3	
14	FAN JACKSHAFT DRIVE	1	191305C1	
15	FEEDER JACKSHAFT DRIVE	1	1313095C2	
15	FEEDER JACKSHAFT DRIVE	1	1313097C3	
19	FAN JACKSHAFT	1	181359C1	X
20	SLOW SPEED FAN JACKSHAFT	1	610521R1	

X - not in standard offer

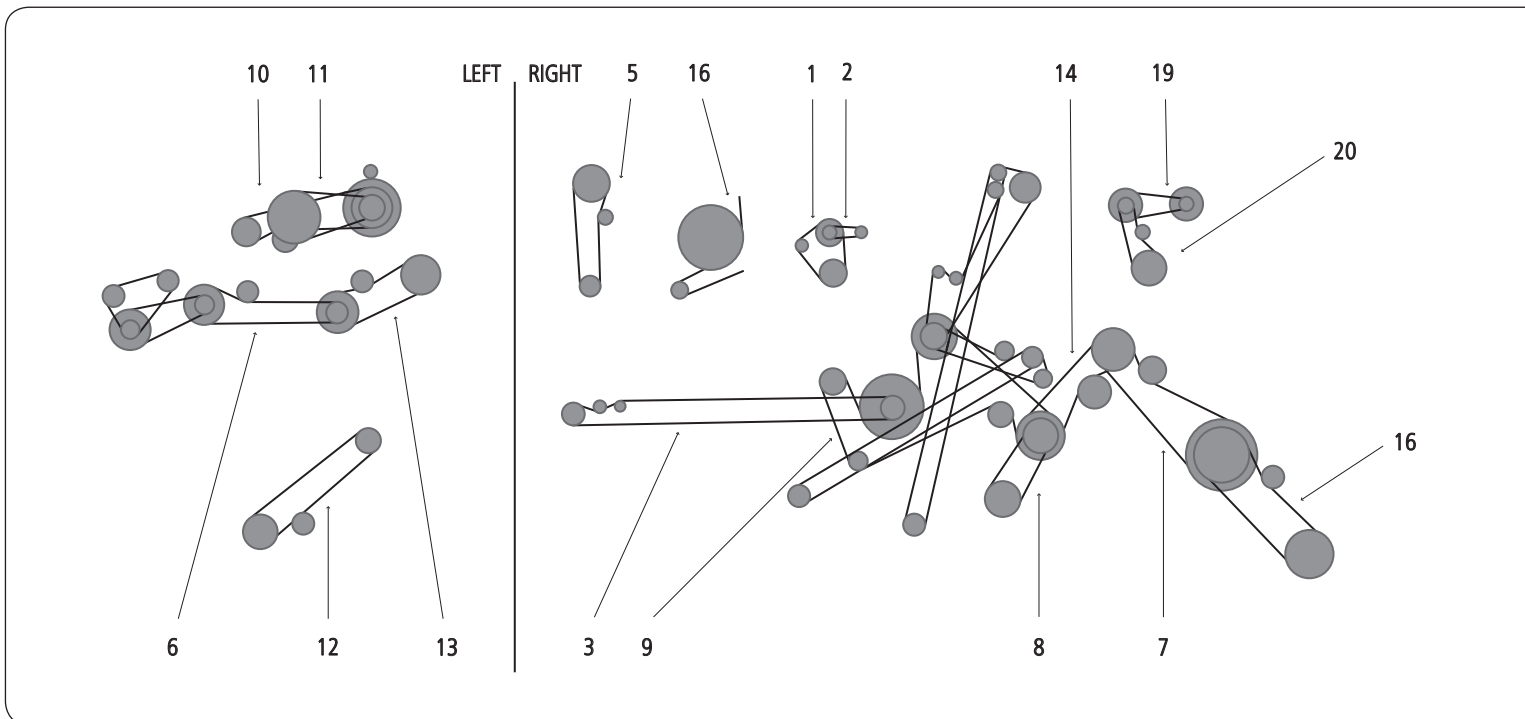

ITEM	APPLICATION	QUANTITY OF V-BELTS IN DRIVE	OE PART NUMBER	COMMENT
1	WATER PUMP, FAN ALTERNATOR	1	537072R92	X
2	AIR CONDITIONING COMPRESSOR	1	874097C1	X
3	STRAW SPREADER DRIVE	1	196371C1	
5	STRAW CHOPPER DRIVE	1	181012C1	
6	UNLOADER AUGER DRIVE	1	191290C1	
7	FEEDER DRIVE	1	192738C1	
8	CLEANING FAN DRIVE	1	195396C2	
9	ELEVATOR DRIVE UNIT	1	186509C2	X
10	SEPARATOR DRIVE	1	191241C3	
11	ROTOR VARIATOR DRIVE	1	244420A1	X
12	REEL DRIVE PUMP WITHOUT ROCK TRAP	1	197414C2	
12	REEL DRIVE PUMP WITH ROCK TRAP	1	1315315C1	X
12	REEL DRIVE PUMP WITHOUT ROCK TRAP	1	197411C1	
13	AUXILIARY PUMP DRIVE	1	191288C3	
14	FAN JACKSHAFT DRIVE	1	191305C1	
15	FEEDER JACKSHAFT DRIVE	1	1313095C2	
15	FEEDER JACKSHAFT DRIVE	1	1313097C3	
16	CLEANING UNIT DRIVE WITH STRAW CHOPPER	1	181055C1	
19	FAN JACKSHAFT	1	181359C1	X
20	SLOW SPEED FAN JACKSHAFT	1	610521R1	

X - not in standard offer

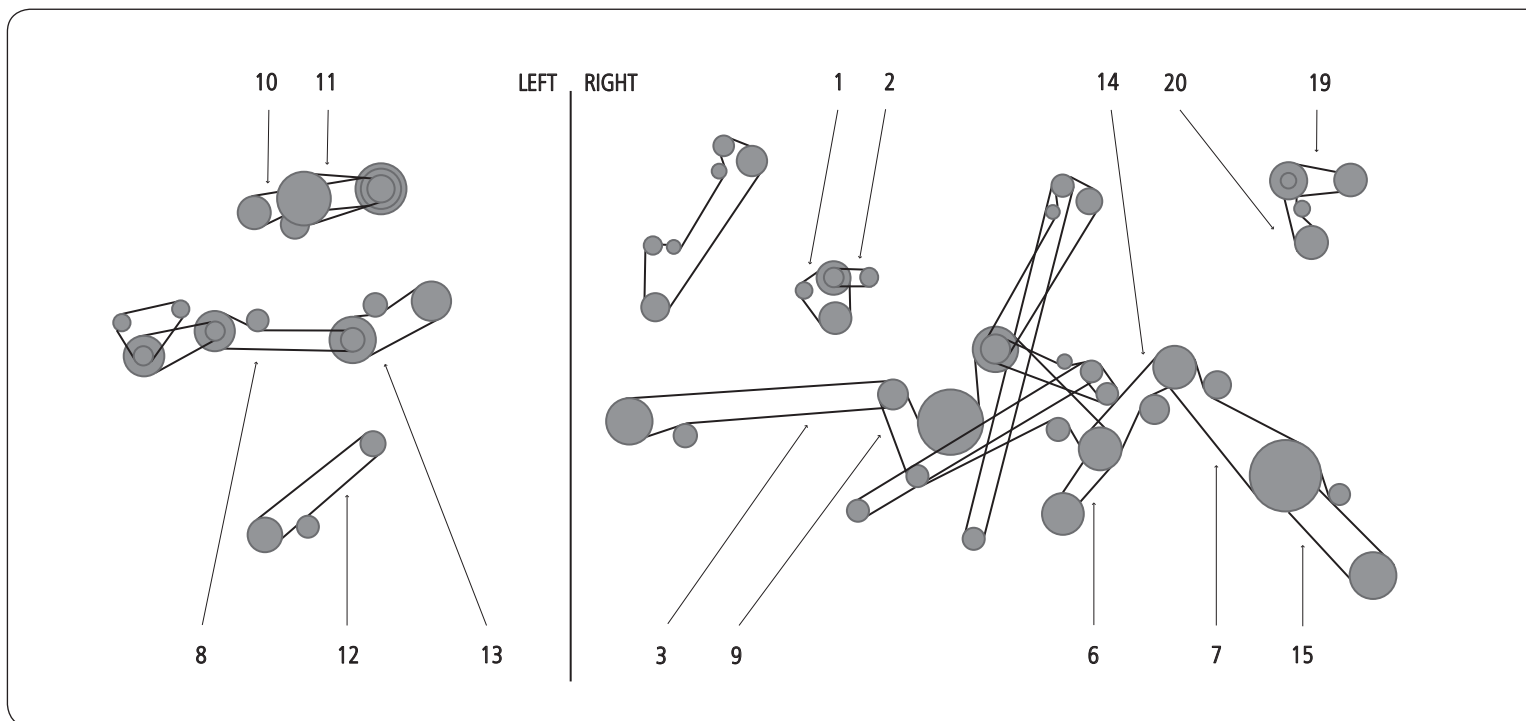

ITEM	APPLICATION	QUANTITY OF V-BELTS IN DRIVE	OE PART NUMBER	COMMENT
1	WATER PUMP, FAN ALTERNATOR	1	537072R92	X
2	AIR CONDITIONING COMPRESSOR	1	874097C1	X
3	STRAW SPREADER DRIVE	1	153359C1	
6	UNLOADER AUGER DRIVE	1	191291C1	
7	FEEDER DRIVE	1	194528C1	
8	CLEANING FAN DRIVE	1	195396C2	
9	ELEVATOR DRIVE UNIT	1	186509C2	X
10	SEPARATOR DRIVE	1	191244C1	
11	ROTOR VARIATOR DRIVE	1	244422A1	X
12	REEL DRIVE PUMP WITHOUT ROCK TRAP	1	197414C2	
12	REEL DRIVE PUMP WITH ROCK TRAP	1	197480C2	
13	AUXILIARY PUMP DRIVE	1	191288C3	
14	FAN JACKSHAFT DRIVE	1	188213C1	
15	FEEDER JACKSHAFT DRIVE	1	1313097C3	
15	FEEDER JACKSHAFT DRIVE	1	1308489C2	
19	FAN JACKSHAFT	1	181359C1	X
20	SLOW SPEED FAN JACKSHAFT	1	610521R1	

X - not in standard offer

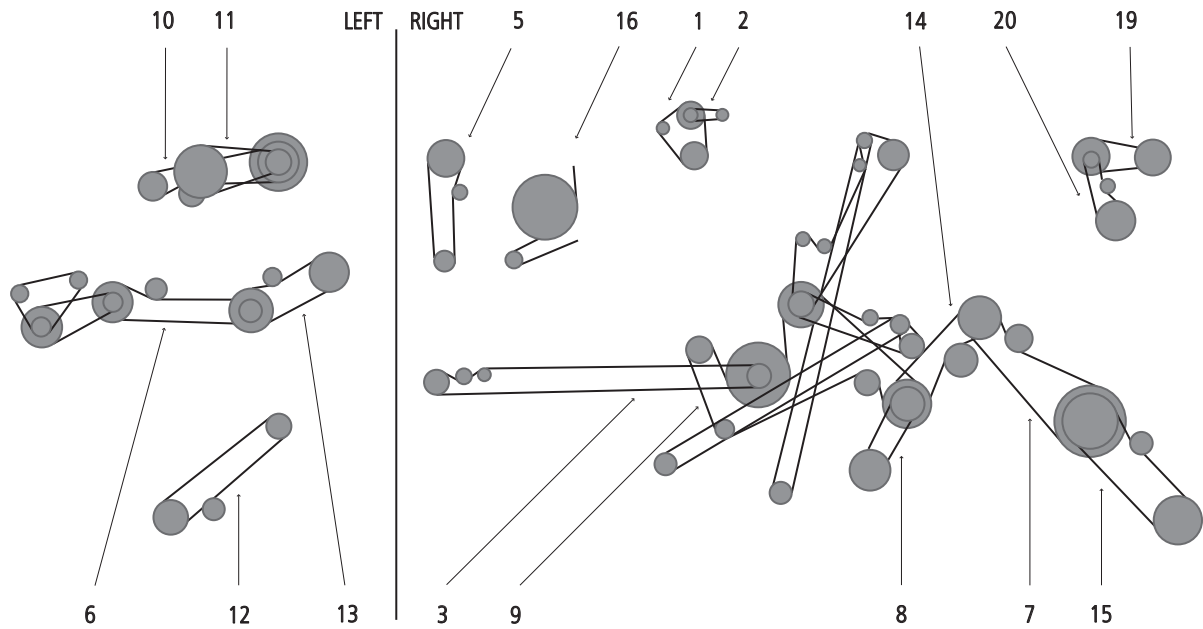

ITEM	APPLICATION	QUANTITY OF V-BELTS IN DRIVE	OE PART NUMBER	COMMENT
1	WATER PUMP, FAN ALTERNATOR	1	537072R92	X
2	AIR CONDITIONING COMPRESSOR	1	874097C1	X
3	STRAW SPREADER DRIVE	1	196371C1	
5	STRAW CHOPPER DRIVE	1	181013C1	
6	UNLOADER AUGER DRIVE	1	191291C1	
7	FEEDER DRIVE	1	194528C1	
8	CLEANING FAN DRIVE	1	195396C2	
9	ELEVATOR DRIVE UNIT	1	186509C2	X
10	SEPARATOR DRIVE	1	191244C1	
11	ROTOR VARIATOR DRIVE	1	244422A1	X
12	REEL DRIVE PUMP	1	197414C2	
12	REEL DRIVE PUMP	1	197480C2	
13	AUXILIARY PUMP DRIVE	1	191288C3	
14	FAN JACKSHAFT DRIVE	1	188213C1	
15	FEEDER JACKSHAFT DRIVE	1	1313097C3	
15	FEEDER JACKSHAFT DRIVE	1	1308489C2	
16	CLEANING UNIT DRIVE WITH STRAW CHOPPER	1	181055C1	
19	FAN JACKSHAFT	1	181359C1	X
20	SLOW SPEED FAN JACKSHAFT	1	610521R1	

X - not in standard offer

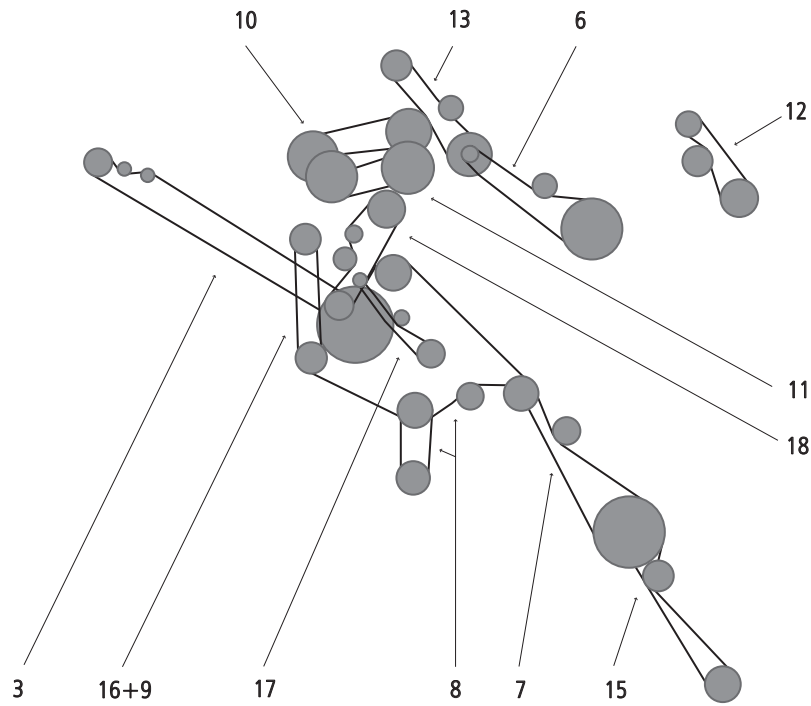

ITEM	APPLICATION	QUANTITY OF V-BELTS IN DRIVE	OE PART NUMBER	COMMENT
1	WATER PUMP, FAN ALTERNATOR	1	130724C91	
2	AIR CONDITIONING COMPRESSOR	1	280210C2	
2	AIR CONDITIONING COMPRESSOR	1	874097C1	X
3	STRAW SPREADER DRIVE	1	589622R1	
5	STRAW CHOPPER DRIVE	1	182945C1	
6	UNLOADER AUGER DRIVE	1	195143C1	
7	FEEDER DRIVE	1	186509C2	X
7	FEEDER DRIVE	1	186377C1	
8	CLEANING FAN DRIVE	1	599060R1	
9	ELEVATOR DRIVE UNIT	1	183049C1	
10	SEPARATOR DRIVE	1	191241C3	
11	ROTOR VARIATOR DRIVE	1	1302174C1	X
12	REEL DRIVE PUMP	1	197414C2	
13	AUXILIARY PUMP DRIVE	1	191288C3	
15	FEEDER JACKSHAFT DRIVE	1	197412C1	
16	CLEANING UNIT DRIVE WITH STRAW CHOPPER	1	186509C2	X
17	TAILINGS ELEVATOR DRIVE	1	674965R2	X
18	GRAIN ELEVATOR DRIVE	1	182619C1	
18	GRAIN ELEVATOR DRIVE	1	181433C1	

X - not in standard offer

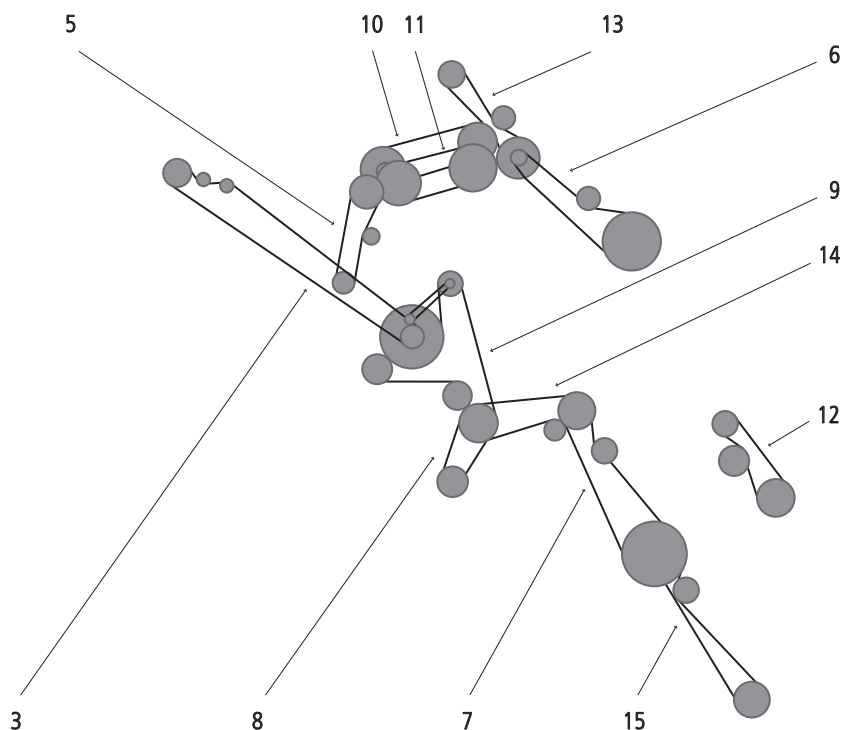

ITEM	APPLICATION	QUANTITY OF V-BELTS IN DRIVE	OE PART NUMBER	COMMENT
1	WATER PUMP, FAN ALTERNATOR	1	537072R92	X
2	AIR CONDITIONING COMPRESSOR	1	164550R2	
3	STRAW SPREADER DRIVE	1	196371C1	
5	STRAW CHOPPER DRIVE	1	1315265C1	
6	UNLOADER AUGER DRIVE	1	191290C1	
7	FEEDER DRIVE WITHOUT ROCK TRAP	1	192738C1	
7	FEEDER DRIVE WITH ROCK TRAP	1	1315168C1	
8	CLEANING FAN DRIVE	1	195396C2	
9	ELEVATOR DRIVE UNIT	1	181055C1	
10	SEPARATOR DRIVE	1	191241C3	
11	ROTOR VARIATOR DRIVE	1	244420A1	X
12	REEL DRIVE PUMP	1	1321564C2	X
12	REEL DRIVE PUMP	1	1321565C1	
13	AUXILIARY PUMP DRIVE	1	191288C3	
14	FAN JACKSHAFT DRIVE	1	191305C1	
15	FEEDER JACKSHAFT DRIVE	1	1313095C2	
15	FEEDER JACKSHAFT DRIVE	1	1313097C3	
19	FAN JACKSHAFT	1	181359C1	X
20	SLOW SPEED FAN JACKSHAFT	1	610521R1	

X - not in standard offer

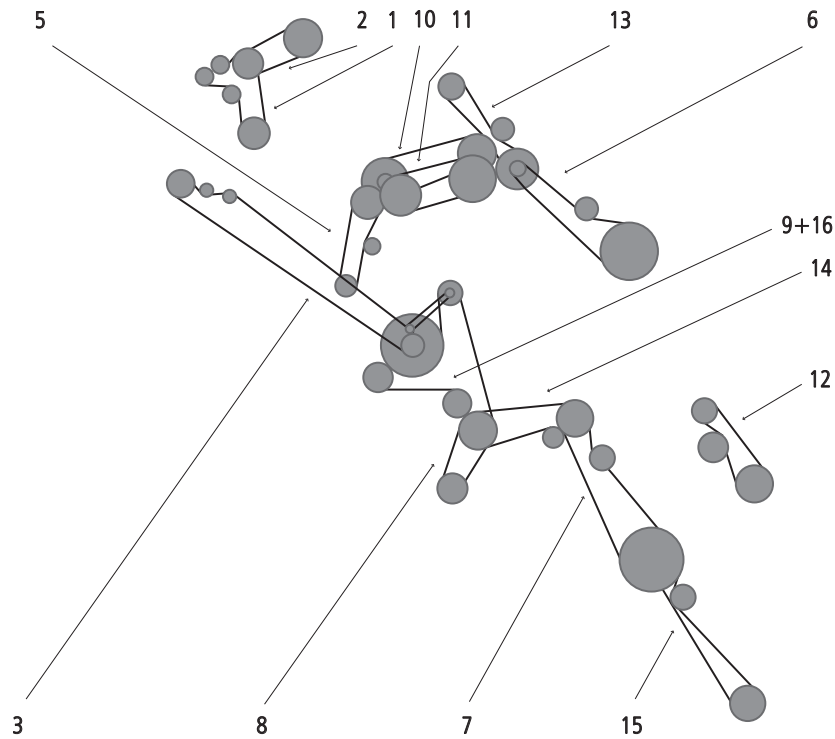

ITEM	APPLICATION	QUANTITY OF V-BELTS IN DRIVE	OE PART NUMBER	COMMENT
1	WATER PUMP, FAN ALTERNATOR	1	J911562	X
2	AIR CONDITIONING COMPRESSOR	1	L72739	
3	STRAW SPREADER DRIVE	1	196371C1	
5	STRAW CHOPPER DRIVE	1	1347157C1	
6	UNLOADER AUGER DRIVE	1	191290C1	
6	UNLOADER AUGER DRIVE	1	1989216C1	
7	FEEDER DRIVE WITHOUT ROCK TRAP	1	192738C1	
7	FEEDER DRIVE WITH ROCK TRAP	1	1315168C1	
8	CLEANING FAN DRIVE	1	195396C2	
9	ELEVATOR DRIVE UNIT	1	186509C2	X
10	SEPARATOR DRIVE	1	191241C3	
11	ROTOR VARIATOR DRIVE	1	244420A1	X
12	REEL DRIVE PUMP (47)	1	1321564C2	X
12	REEL DRIVE PUMP (54.5)	1	1321565C2	
12	REEL DRIVE PUMP (54.5)	1	1330311C2	X
12	REEL DRIVE PUMP (47)	1	1979606C1	
13	AUXILIARY PUMP DRIVE	1	1347387C1	
13	AUXILIARY PUMP DRIVE	1	1970115C1	
14	FAN JACKSHAFT DRIVE	1	191305C1	
15	FEEDER JACKSHAFT DRIVE	1	1313095C2	
15	FEEDER JACKSHAFT DRIVE	1	1313097C3	
16	CLEANING UNIT DRIVE WITH STRAW CHOPPER	1	181055C1	
19	FAN JACKSHAFT	1	181359C1	X
20	SLOW SPEED FAN JACKSHAFT	1	610521R1	

X - not in standard offer

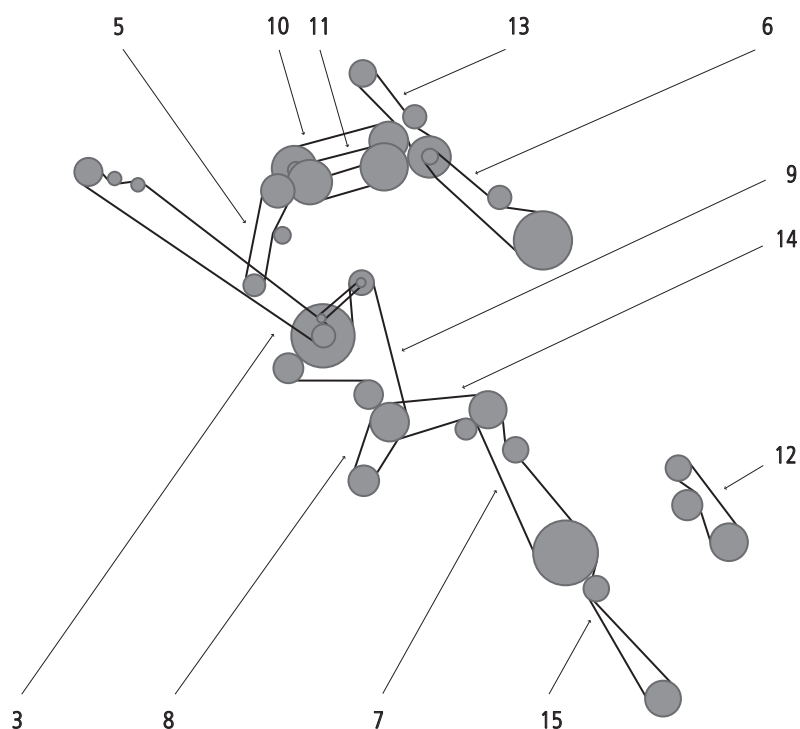

ITEM	APPLICATION	QUANTITY OF V-BELTS IN DRIVE	OE PART NUMBER	COMMENT
1	WATER PUMP, FAN ALTERNATOR	1	537072R92	X
2	AIR CONDITIONING COMPRESSOR	1	164550R2	
3	STRAW SPREADER DRIVE	1	196371C1	
5	STRAW CHOPPER DRIVE	1	1315265C1	
6	UNLOADER AUGER DRIVE	1	191290C1	
7	FEEDER DRIVE WITHOUT ROCK TRAP	1	192738C1	
7	FEEDER DRIVE WITH ROCK TRAP	1	1315168C1	
8	CLEANING FAN DRIVE	1	195396C2	
9	ELEVATOR DRIVE UNIT	1	181055C1	
10	SEPARATOR DRIVE	1	191241C3	
11	ROTOR VARIATOR DRIVE	1	244420A1	X
12	REEL DRIVE PUMP	1	1321564C2	X
12	REEL DRIVE PUMP	1	1321565C1	
13	AUXILIARY PUMP DRIVE	1	191288C3	
14	FAN JACKSHAFT DRIVE	1	191305C1	
15	FEEDER JACKSHAFT DRIVE	1	1313095C2	
15	FEEDER JACKSHAFT DRIVE	1	1313097C3	
19	FAN JACKSHAFT	1	181359C1	X
20	SLOW SPEED FAN JACKSHAFT	1	610521R1	

X - not in standard offer

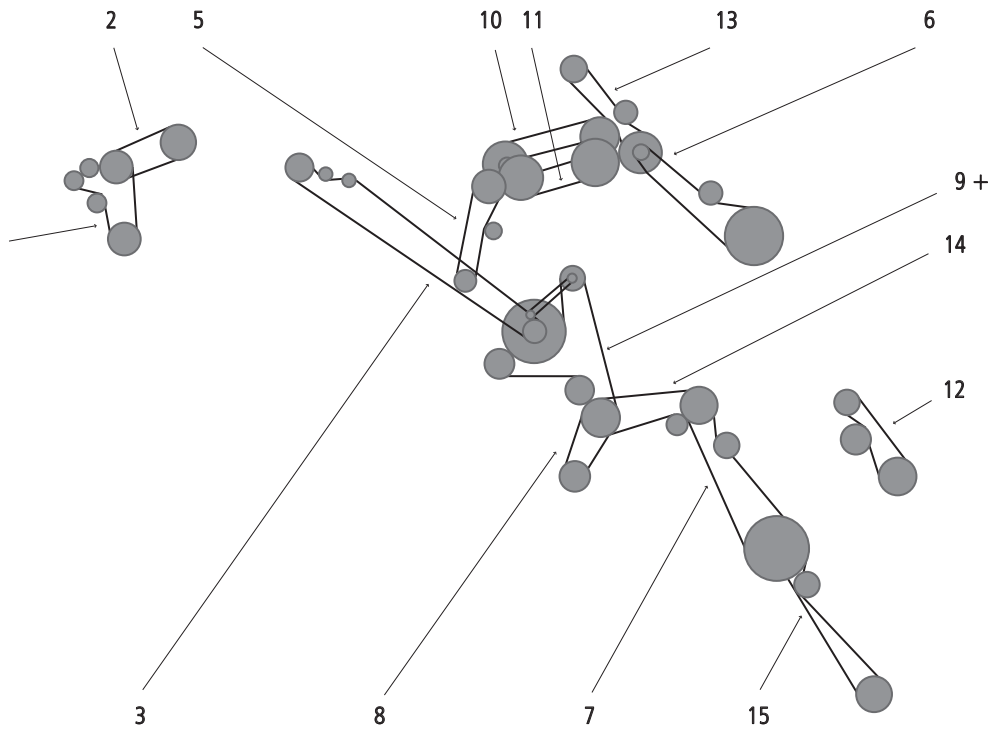

ITEM	APPLICATION	QUANTITY OF V-BELTS IN DRIVE	OE PART NUMBER	COMMENT
1	WATER PUMP. FAN ALTERNATOR	1	J911572	X
1	WATER PUMP. FAN ALTERNATOR	1	J911574	X
2	AIR CONDITIONING COMPRESSOR	1	396829R1	
3	STRAW SPREADER DRIVE	1	196371C1	
5	STRAW CHOPPER DRIVE	1	1347157C1	
5	STRAW CHOPPER DRIVE	1	1315265C1	
6	UNLOADER AUGER DRIVE	1	191290C1	
6	UNLOADER AUGER DRIVE	1	1989216C1	
7	FEEDER DRIVE WITHOUT ROCK TRAP	1	192738C1	
7	FEEDER DRIVE WITH ROCK TRAP	1	1315168C1	
8	CLEANING FAN DRIVE	1	1541569C1	
8	CLEANING FAN DRIVE	1	195396C2	
9	ELEVATOR DRIVE UNIT	1	186509C2	X
10	SEPARATOR DRIVE	1	191241C3	
11	ROTOR VARIATOR DRIVE	1	244420A1	X
12	REEL DRIVE PUMP (47)	1	1321564C2	X
12	REEL DRIVE PUMP (54.5)	1	1321565C2	
12	REEL DRIVE PUMP (54.5)	1	1330311C2	X
12	REEL DRIVE PUMP (47)	1	1979606C1	
13	AUXILIARY PUMP DRIVE	1	1347387C1	
13	AUXILIARY PUMP DRIVE	1	1541699C1	X
13	AUXILIARY PUMP DRIVE	1	1970115C1	
14	FAN JACKSHAFT DRIVE	1	191305C1	
15	FEEDER JACKSHAFT DRIVE	1	1313095C2	
15	FEEDER JACKSHAFT DRIVE	1	1313097C3	
16	CLEANING UNIT DRIVE WITH STRAW CHOPPER	1	181055C1	
19	FAN JACKSHAFT	1	181359C1	X
20	SLOW SPEED FAN JACKSHAFT	1	610521R1	
21	CHAFT SPREADER. UPPER	1	123305A1	
22	CHAFT SPREADER. LOWER	1	123306A1	

X - not in standard offer

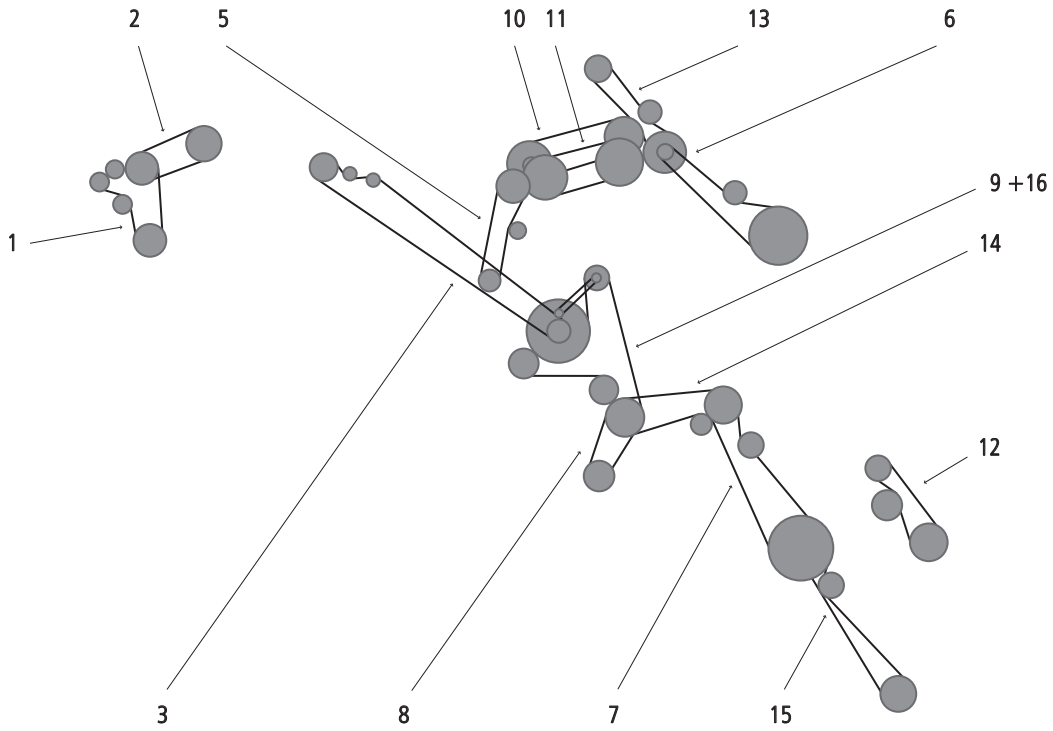

ITEM	APPLICATION	QUANTITY OF V-BELTS IN DRIVE	OE PART NUMBER	COMMENT
1	WATER PUMP. FAN ALTERNATOR	1	J911572	X
1	WATER PUMP. FAN ALTERNATOR	1	J911574	X
2	AIR CONDITIONING COMPRESSOR	1	396829R1	
3	STRAW SPREADER DRIVE	1	196371C1	
5	STRAW CHOPPER DRIVE	1	1347160C1	
5	STRAW CHOPPER DRIVE	1	1315266C1	
6	UNLOADER AUGER DRIVE	1	191291C1	
6	UNLOADER AUGER DRIVE	1	1989217C1	
7	FEEDER DRIVE	1	194528C1	
8	CLEANING FAN DRIVE	1	1541569C1	
8	CLEANING FAN DRIVE	1	195396C2	
9	ELEVATOR DRIVE UNIT	1	186509C2	X
10	SEPARATOR DRIVE	1	1330499C1	
10	SEPARATOR DRIVE	1	1541702C1	
11	ROTOR VARIATOR DRIVE	1	244422A1	X
12	REEL DRIVE PUMP (60)	1	1315226C1	
12	REEL DRIVE PUMP (54.5)	1	1321565C1	
12	REEL DRIVE PUMP (54.5)	1	1330311C2	X
12	REEL DRIVE PUMP (60)	1	1979607C1	X
13	AUXILIARY PUMP DRIVE	1	1347358C1	
13	AUXILIARY PUMP DRIVE	1	1541700C1	X
13	AUXILIARY PUMP DRIVE	1	1970116C1	
14	FAN JACKSHAFT DRIVE	1	188213C1	
15	FEEDER JACKSHAFT DRIVE	1	1313097C3	
15	FEEDER JACKSHAFT DRIVE	1	1308489C2	
16	CLEANING UNIT DRIVE WITH STRAW CHOPPER	1	181055C1	
19	FAN JACKSHAFT	1	181359C1	X
20	SLOW SPEED FAN JACKSHAFT	1	610521R1	
21	CHAFT SPREADER. UPPER	1	123305A1	
22	CHAFT SPREADER. LOWER	1	123307A1	

X - not in standard offer

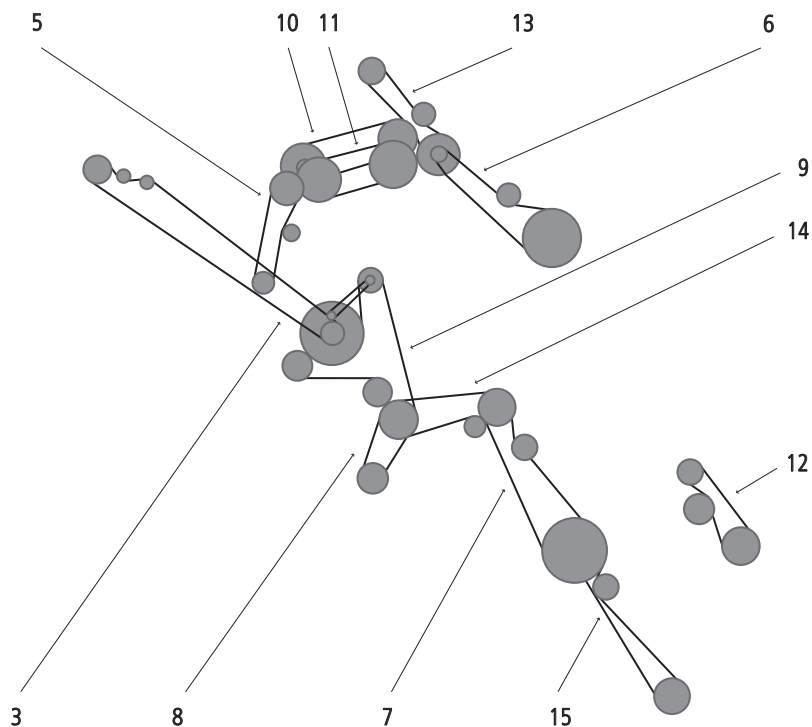

ITEM	APPLICATION	QUANTITY OF V-BELTS IN DRIVE	OE PART NUMBER	COMMENT
1	WATER PUMP, FAN ALTERNATOR	1	131201C92	
2	AIR CONDITIONING COMPRESSOR	1	1250587C1	
3	STRAW SPREADER DRIVE	1	196371C1	
5	STRAW CHOPPER DRIVE	1	1315266C1	
6	UNLOADER AUGER DRIVE	1	191291C1	
7	FEEDER DRIVE WITH ROCK TRAP	1	1315074C1	
7	FEEDER DRIVE WITHOUT ROCK TRAP	1	194528C1	
8	CLEANING FAN DRIVE	1	195396C2	
9	ELEVATOR DRIVE UNIT	1	186509C2	X
10	SEPARATOR DRIVE	1	191244C1	
11	ROTOR VARIATOR DRIVE	1	244422A1	X
12	REEL DRIVE PUMP	1	1315226C1	
12	REEL DRIVE PUMP	1	1321565C1	
13	AUXILIARY PUMP DRIVE	1	191288C3	
14	FAN JACKSHAFT DRIVE	1	188213C1	
15	FEEDER JACKSHAFT DRIVE	1	1313097C3	
15	FEEDER JACKSHAFT DRIVE	1	1308489C2	
16	CLEANING UNIT DRIVE WITH STRAW CHOPPER	1	181055C1	
19	FAN JACKSHAFT	1	181359C1	X
20	SLOW SPEED FAN JACKSHAFT	1	610521R1	

X - not in standard offer

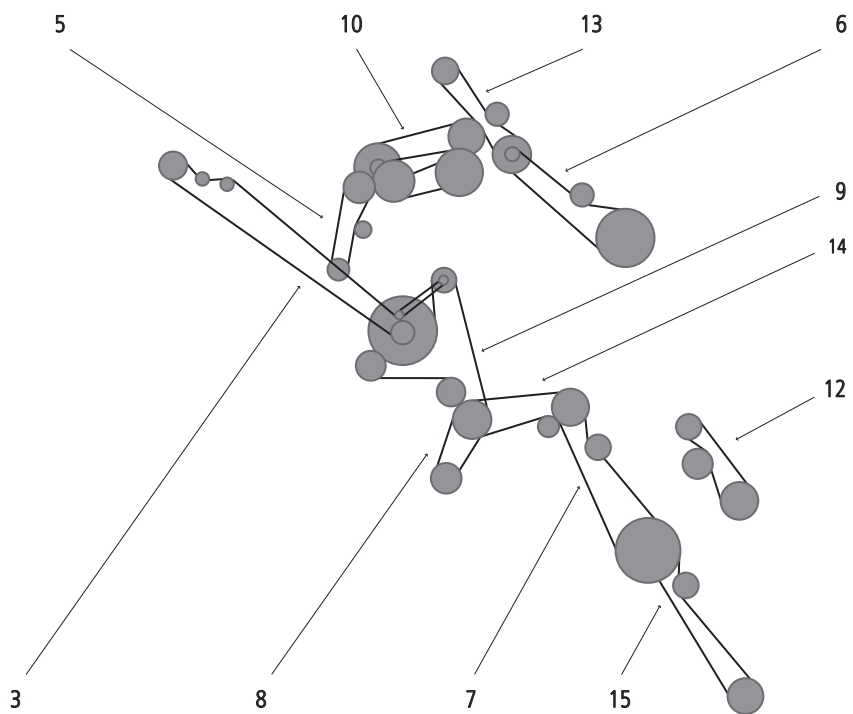

ITEM	APPLICATION	QUANTITY OF V-BELTS IN DRIVE	OE PART NUMBER	COMMENT
1	BALER	1	506880.0	
1	BALER	1	506940.0	
2	ALTERNATOR	1	624131.0	
2	ALTERNATOR	1	750296.0	
2	ALTERNATOR	1	750624.0	
3	KNIFE DRIVE	1	756051.0	
3	KNIFE DRIVE	1	801221.0	
4	TANK UNLOADER	1	756059.0	
5	CUTTING TABLE	1	772657.0	
6	GRAIN SPREADER IN TANK	1	775698.0	
7	PICK-UP	1	800309.0	
8	SHAKER SHOE. FANNING MILL	1	506023.0	
9	THRESHING MACHINE	1	801222.0	
10	TRACTION DRIVE	1	750294.0	
11	TRACTION DRIVE	1	751112.0	
12	SHAKER SHOE. FANNING MILL	1	772658.0	
12	SHAKER SHOE. FANNING MILL	1	772660.0	
13	STRAW WALKER. ELEVATOR	1	773313.0	
13	STRAW WALKER. ELEVATOR	1	774100.0	

X - not in standard offer

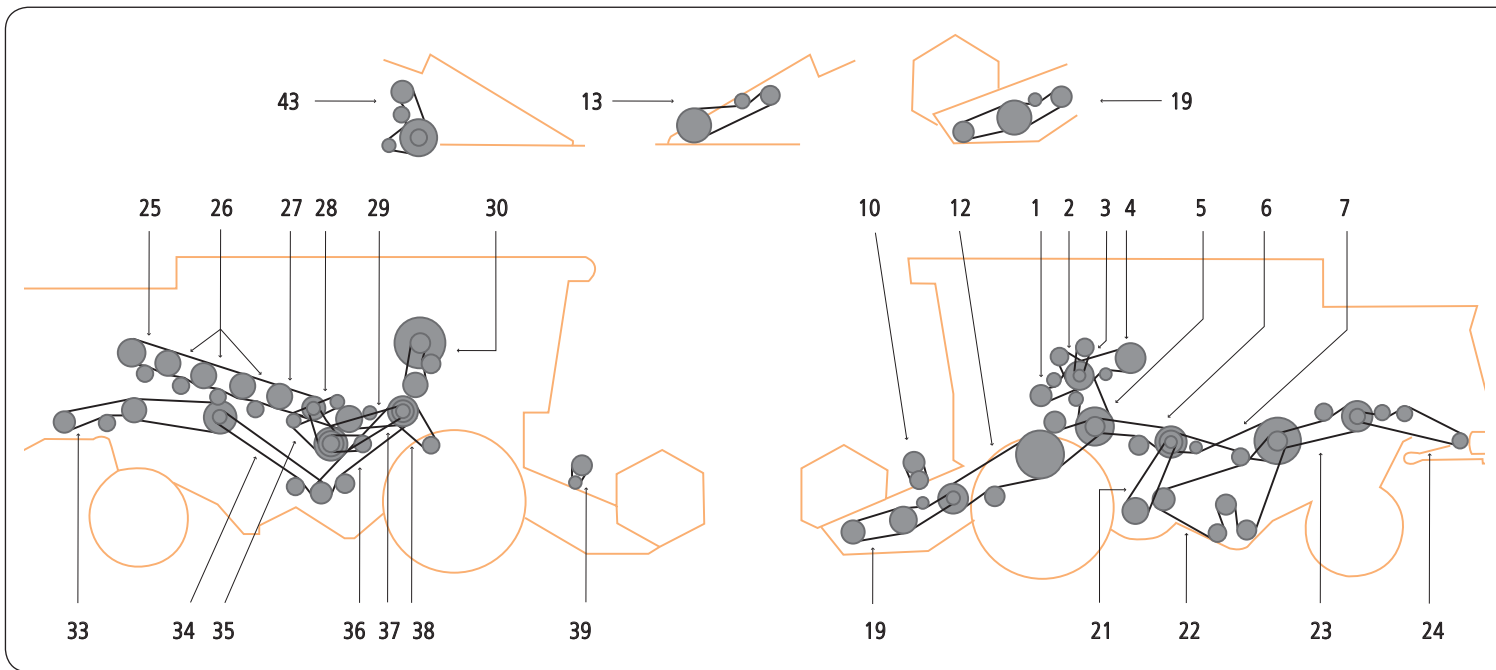

ITEM	APPLICATION	QUANTITY OF V-BELTS IN DRIVE	OE PART NUMBER	COMMENT
1		1	629279.0	
2		1	629002.1	
3		1	629908.1	
4		1	629763.0	
5		1	629000.1	
6		1	603337.0	
7		1	644141.0	
10	TO 5.1 M CUTTING TABLE	1	670224.1	X
12		1	603017.3	
13	FOR MAIZE PICKER	1	692149.0	
13	FOR MAIZE PICKER	1	692150.0	
16	FROM 6.0 M CUTTING TABLE	1	671013.1	
19	TO 5.1 M CUTTING TABLE	1	713506.2	
21		1	603380.0	
22		1	609762.0	
23	FOR STRAW DISTRIBUTOR	1	506671.1	
24	FOR STRAW DISTRIBUTOR	1	640653.1	
25		1	644014.1	
26		1	644015.1	
27		1	644016.1	
29		1	064168.2	
30		1	233843.1	
33	FOR MAIZE	1	061872.0	
33	FOR GRAIN	1	061701.1	
34	FOR STRAW CHOPPER	1	061700.0	
35		1	603247.1	
37		1	644014.1	
38	CYLINDER BY 650-1500 RPM	1	628630.0	
38	CYLINDER BY 500-1400 RPM	1	644177.0	X
39	FROM 6.0 M CUTTING TABLE	1	670224.1	X
43		1	680334.1	

X - not in standard offer

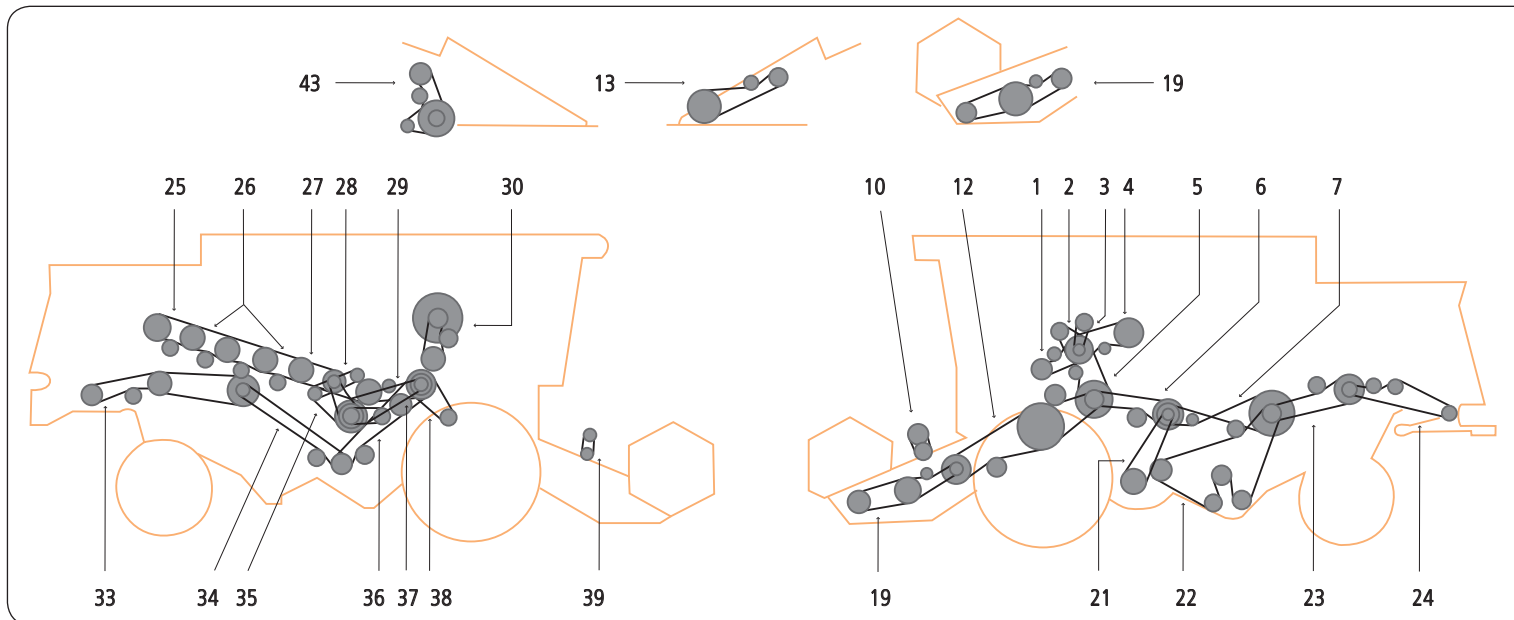

ITEM	APPLICATION	QUANTITY OF V-BELTS IN DRIVE	OE PART NUMBER	COMMENT
1		1	644017.0	
2		1	629002.1	
3		1	629908.1	
4		1	629763.0	
5		1	644018.1	
6		1	603337.0	
7		1	644141.0	
10	TO 5.1 M CUTTING TABLE	1	670224.1	X
12		1	603017.3	
13	FOR MAIZE PICKER	1	692149.0	
13	FOR MAIZE PICKER	1	692150.0	
16	FROM 6.0 M CUTTING TABLE	1	671013.1	
19	TO 5.1 M CUTTING TABLE	1	713506.2	
21		1	603380.0	
22		1	609762.0	
23	FOR STRAW DISTRIBUTOR	1	506671.1	
24	FOR STRAW DISTRIBUTOR	1	640653.1	
25		1	644014.1	
26		1	644015.1	
27		1	644016.1	
29		1	064168.2	
30		1	233843.1	
33	FOR MAIZE	1	061872.0	
33	FOR GRAIN	1	061701.1	
34	FOR STRAW CHOPPER	1	061700.0	
35		1	603247.1	
36	FOR STRAW CHOPPER	1	061700.0	
37		1	644014.1	
38	CYLINDER BY 650-1500 RPM	1	628630.0	
38	CYLINDER BY 500-1400 RPM	1	644177.0	X
39	FROM 6.0 M CUTTING TABLE	1	670224.1	X
42		1	695610.1	X
43		1	680334.1	

X - not in standard offer

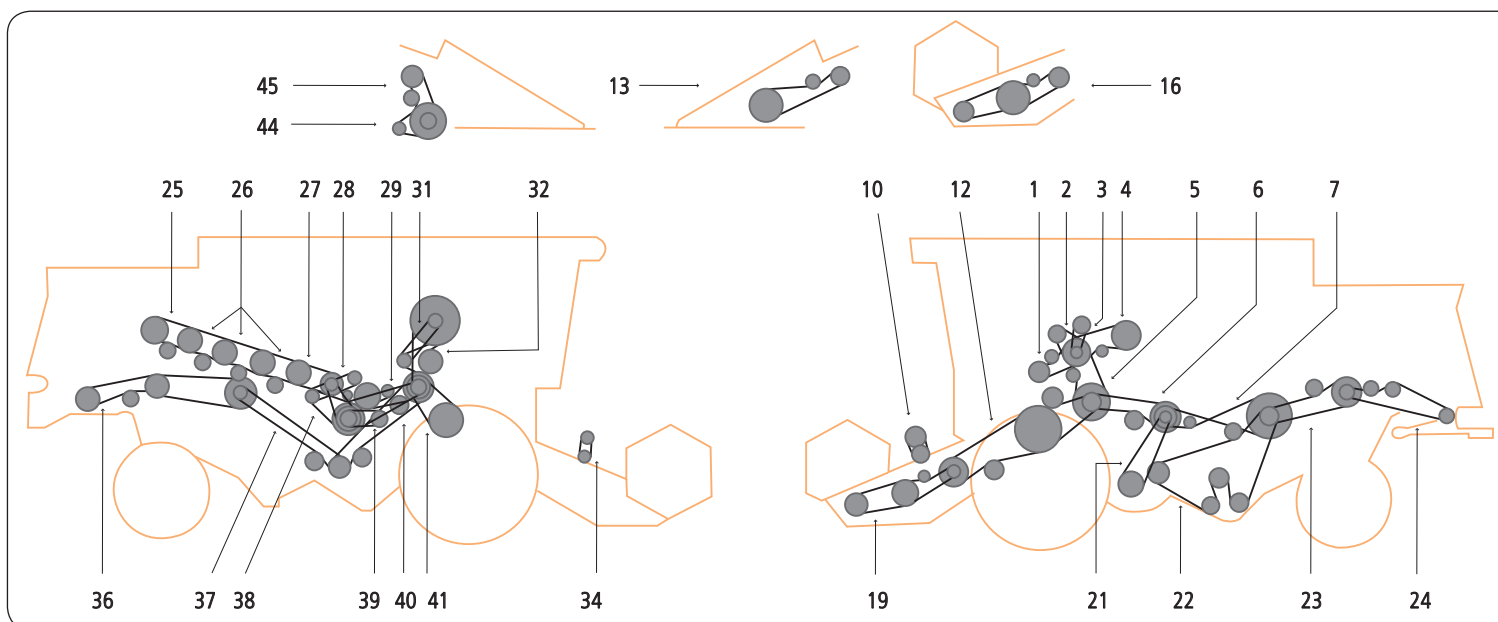

ITEM	APPLICATION	QUANTITY OF V-BELTS IN DRIVE	OE PART NUMBER	COMMENT
1	TRAVEL DRIVE - FROM NO 15900371	1	644017.0	
1	HYDRAULIC PUMP - TO NO 15900370	1	661092.1	
2	HYDRAULIC PUMP - FROM NO 15900371	1	629002.1	
2	AIR CONDITION	1	633030.2	
3	TANK UNLOADING - FROM NO 15900371	1	629908.1	
4	TANK UNLOADING - TO NO 15900370	1	661093.0	
4	THRESHING CYLINDER - TO NO 15900370	1	629763.0	
5	THRESHING MACHINE - FROM NO 15900371	1	644018.1	
5	COUNTERSHAFT - FAN DRIVE	1	644403.0	
6	SHAKER SHOE DRIVE - FROM NO 15900371	1	603337.0	
7	SHAKER SHOE DRIVE - TO NO 15900370	1	644141.1	
7	REEL BY 5.1 M CUTTING TABLE	1	603336.0	
10	CONVEYOR. SHAFT 1463 MM	1	670224.1	X
12	CONVEYOR. SHAFT 1306 MM TO NO 15900460	1	603017.3	
12	CONVEYOR. SHAFT 1306 MM FROM NO 15900461	1	603430.0	
12	FOR MAIZE PICKER	1	644419.0	
13	FOR MAIZE PICKER. HINGED	1	692149.0	
13	CUTTING TABLE FOR MAIZE	1	692150.0	
13	CUTTING MECH. FROM 6.0 M CUTTING TABLE	1	629142.0	
16	CUTTING MECH. BY 5.1 M CUTTING TABLE	1	671013.1	
19	FAN VARI-DRIVE	1	713506.2	
21	SHAKER SHOE	1	603380.0	
22	FOR STRAW DISTRIBUTOR	1	609762.0	
23	GRAIN DISTRIBUTOR	1	506671.1	
23	STRAW DISTRIBUTOR	1	713506.2	
24	8. SEPARATOR CYLINDER	1	640653.1	
25	3. 5. 6. & 7. SEPARATOR CYLINDER	1	644014.1	
26	4. SEPARATOR CYLINDER	1	644015.1	
27	COUNTERSHAFT VARI-DRIVE	1	644016.1	
28	ROTARY SIEVE DRIVE - TO NO 15900370	1	064168.2	
31	ROTARY SIEVE DRIVE - TO NO 15900150	1	644267.0	
32	ROTARY SIEVE COUNTERSHAFT NO 15900151-15900370	1	633030.2	
32	REEL FROM 6.0 M CUTTING TABLE	1	233839.2	
34	STRAW CHOPPER FOR MAIZE	1	670224.1	x
36	STRAW CHOPPER FOR GRAIN	1	061872.0	

ITEM	APPLICATION	QUANTITY OF V-BELTS IN DRIVE	OE PART NUMBER	COMMENT
36	COUNTERSHAFT II - STRAW CHOPPER	1	061701.1	
37	COUNTERSHAFT - STRAW STRIPPER DRUM	1	061700.0	
38	COUNTERSHAFT I - STRAW CHOPPER	1	603247.1	
39	1. & 2. SEPARATOR CYLINDER	1	061700.0	
40	CYLINDER BY 650-1500 RPM TO NO 15900310	1	644014.1	
41	THRESHING CYLINDER RPM 650-1500 FROM 15900311	1	628630.0	
41	THRESHING CYLINDER WITH TWO-STAGE DRIVE	1	644418.0	
41	CYLINDER BY 500-1400 RPM	1	644418.1	
41		1	644177.0	X
45		1	680334.1	
46	ROTARY SIEVE - FROM NO 15900371	1	661345.0	
47	ROTARY SIEVE COUNTERSHAFT - FROM NO 15900371	1	661245.0	
48	DISTRIBUTOR FROM NO 70910057 BY 531 RPM	1	501925.0	
48	DISTRIBUTOR - TO NO 70910056 BY 531 RPM	1	802931.0	
49	DISTRIBUTOR FROM NO 70910057 BY 676 RPM	1	687046.0	
49	DISTRIBUTOR - TO NO 70910056 BY 676 RPM	1	750288.0	
50	GENERATOR - TO NO 15900370	1	133528.0	
50	GENERATOR - FROM NO 15900371	1	133640.0	
51	WATER PUMP - FROM NO 15900370	1	133630.0	
52	COOLING DUST CLEANER	1	664448.0	X

X - not in standard offer

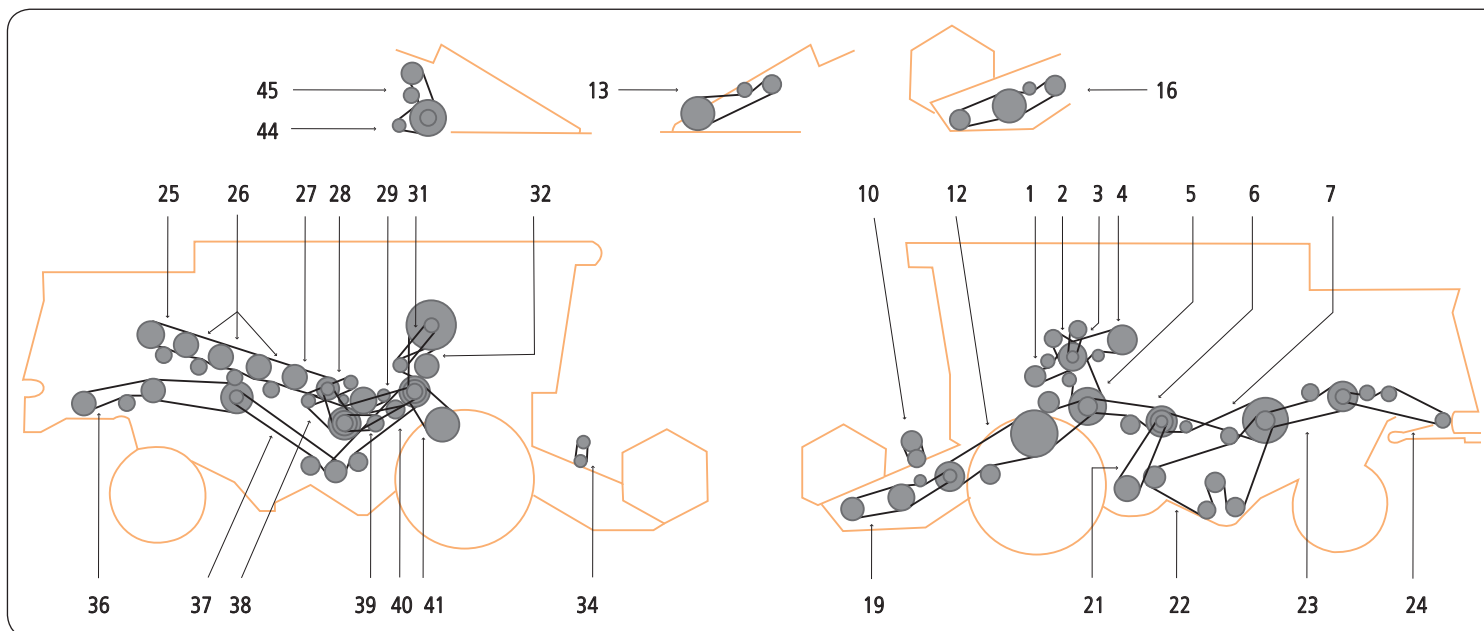

ITEM	APPLICATION	QUANTITY OF V-BELTS IN DRIVE	OE PART NUMBER	COMMENT
1	CUTTING TABLE	1	702509.0	X
2	VARIABLE SPEED	1		
2	CYLINDER DRIVE	1	702536.0	
3	VARIABLE SPEED REEL	1	778561.0	X
4	KNIFE DRIVE	1	778717.0	
5	SHAKER SHOE	1	610830.0	
6	TRACTION VARI-DRIVE	1	702536.0	
7	SHAKER SHOE	1		
7	COUNTERSHAFT	1	703314.0	
8	UNLOADING GRAIN TANK	1	706087.0	
9	STRAW SPREADER	1	706829.0	
10	HYDRAULIC PUMP	1	713506.0	
11	TRACTION DRIVE	1	720695.0	
12	TURNING DRUM DRIVE	1	720696.0	
12	TURNING DRUM DRIVE	1	720866.0	
13	RADIATOR FAN	1	721306.0	
13	RADIATOR FAN	1	721307.0	
14	STRAW WALKER	1	774099.0	
15	VARIABLE SPEED FAN MILL	1	778561.0	X

X - not in standard offer

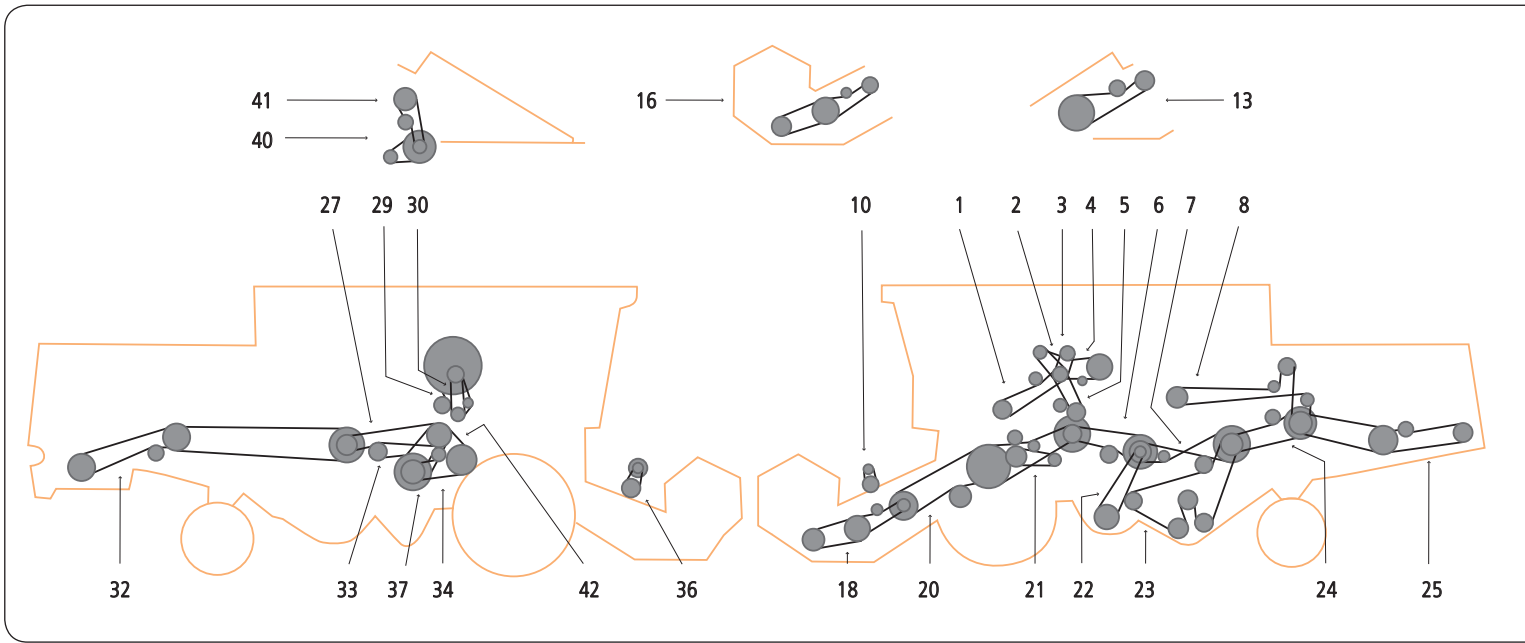

ITEM	APPLICATION	QUANTITY OF V-BELTS IN DRIVE	OE PART NUMBER	COMMENT
3		1	778561.0	X
5		1	724301.0	
8		1	670224.0	X
9		1	724141.0	
10		1	724101.0	
11		1	673614.0	
12		1	767057.0	
13		1	724180.0	
14		1	785176.0	
16		1	724168.0	
17		1	629756.0	
18		1	724248.0	
19		1	603380.0	
24		1	061872.0	
25		1	603015.0	
25		1	603247.0	

X - not in standard offer

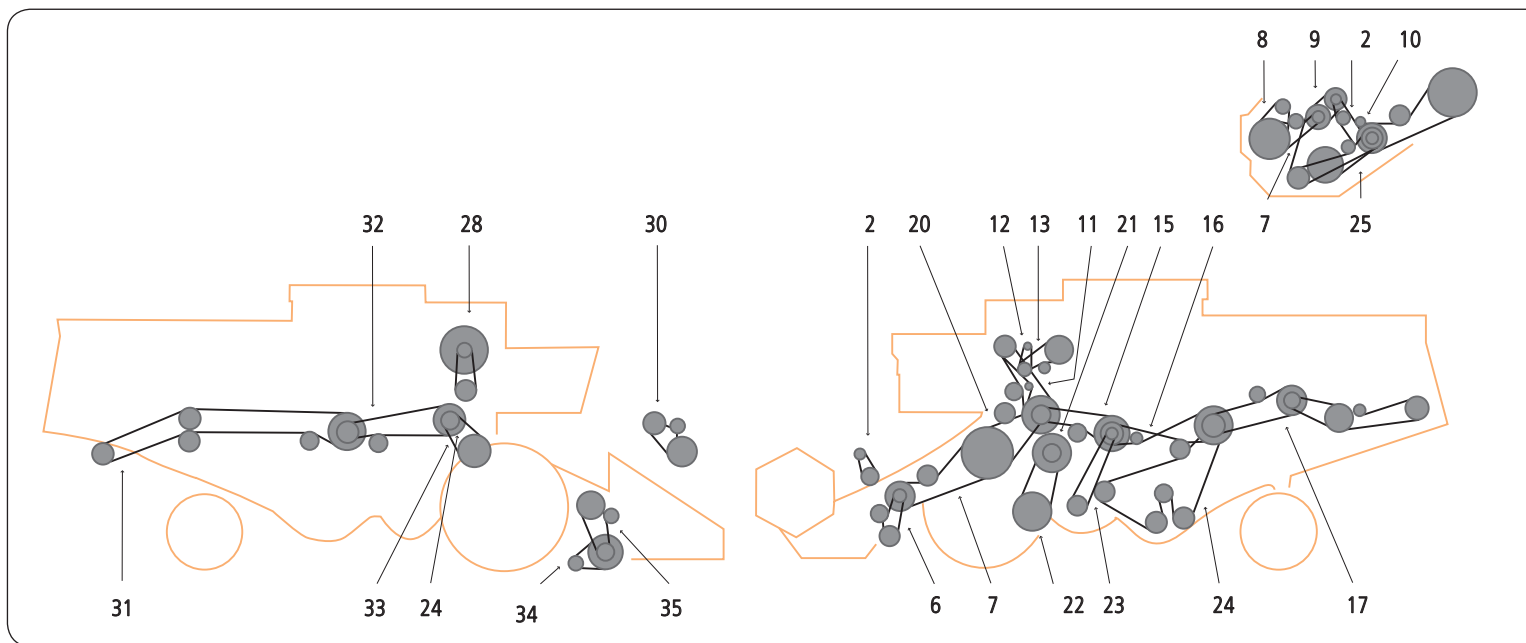

ITEM	APPLICATION	QUANTITY OF V-BELTS IN DRIVE	OE PART NUMBER	COMMENT
2	REEL VARIATOR	1	670224.0	X
6	KNIFE DRIVE	1	629214.0	
7		1	629081.0	
7		1	603122.0	
8		1	603284.0	
9		1	056961.0	
10		1	056961.0	
11	HYDRAULIC PUMP	1	767057.1	
12		1	621903.0	
13	DISCHARGE AUGER	1	673614.0	
14	TRACTION DRIVE	1	671012.0	
15		1	603337.0	
15		1	672358.0	
16	SIEVE DRIVE	1	672359.0	
16		1	603336.0	
17		1	506671.1	
18		1	603283.0	
19		1	603048.0	
20		1	673638.1	X
21		1	629436.0	
22		1	629737.0	
23		1	671209.0	X
24		1	603017.3	
25		1	635494.0	
28		1	783430.1	
30		1	603247.0	
31		1	061361.0	
32	FRONT WHEEL SHAFT	1	060306.2	
33		1	603015.1	
34		1	629410.0	
35		1	680334.1	

X - not in standard offer

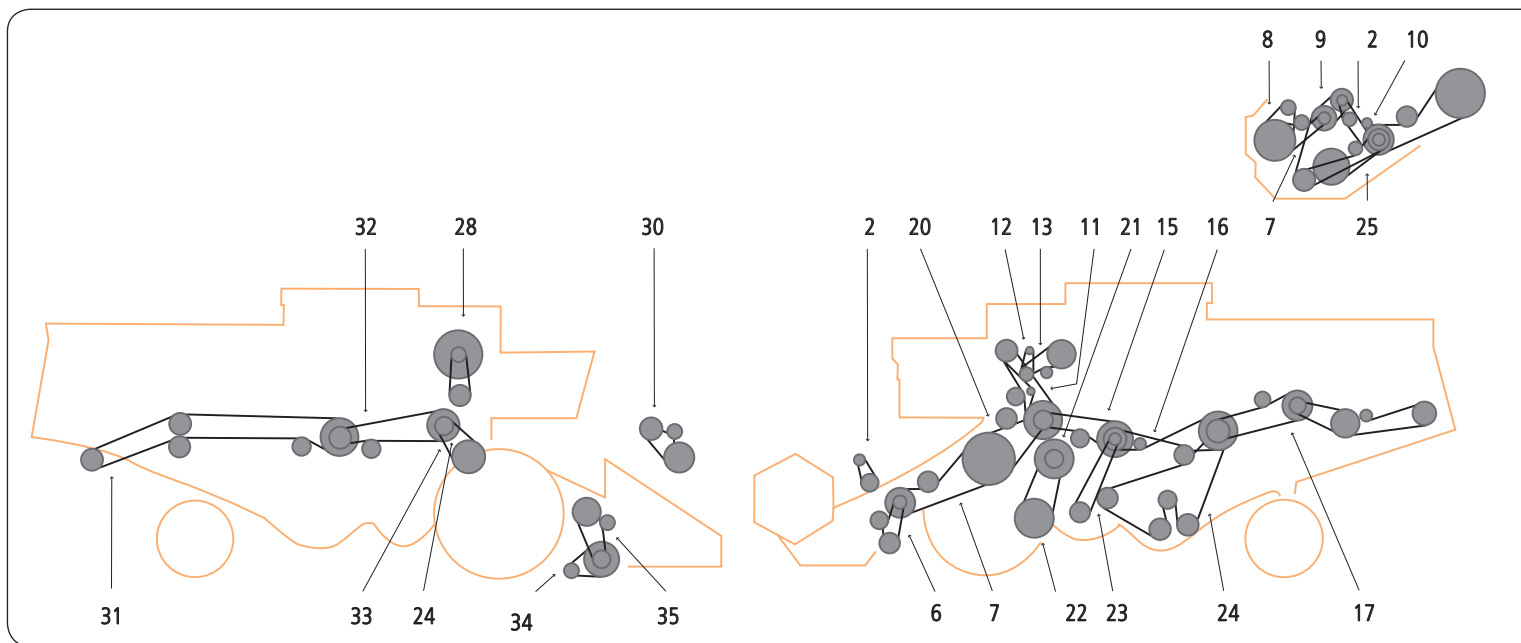

ITEM	APPLICATION	QUANTITY OF V-BELTS IN DRIVE	OE PART NUMBER	COMMENT
1	CUTTING MECH. BY 3.0 M	1	603284.0	
2	CUTTING MECH. BY 3.0 M	1	026961.0	X
3		1	670224.1	X
4	CUTTING MECH. BY 3.0 M	1	056961.0	
5	CUTTING MECH. BY 3.0 M TO CUT. 255806	1	603283.0	
5	BY 3.6 M - 5.1 M TO CUTTING MECH. 255807	1	713506.2	
5	CUTTING MECH. BY 3.6 M TO 5.1 M TO 25580	1	713506.2	
5	TO CUTTING MECH. BY 3.0 TO CUT. 255807	1	778717.1	
6	CUTTING MECH. BY 3.0 M	1	603048.0	
7	2X BY MAIZE PICKET TO NO 15606083	1	603290.0	
7	2X BY MAIZE PICKET TO NO 15606082	1	629836.0	
11		1	724100.0	
12		1	724141.0	
13		1	673614.0	
14		1	767057.1	
15		1	724181.0	
16		1	785176.0	
17		1	802931.0	
18	FOR STRAW DISTRIBUTOR	1	509435.0	
20	CUTTING MECH. TO 3.6 M	1	629214.1	
21		1	673638.1	X
22		1	629756.0	
23		1	603380.1	
24		1	724247.1	
27	BY GRAIN	1	061902.0	
27	BY MAIS	1	062043.0	
28		1	061872.0	
30	BY N 650-1550 RPM TO NO 15603256	1	603015.1	
30	BY N 650-1500 RMP TO NO 15603257	1	628630.0	
30	BY N 500-1400 RPM	1	644177.0	X
31		1	629410.0	
32		1	680334.1	
33	AIR CONDITIONING	1	783268.1	

X - not in standard offer

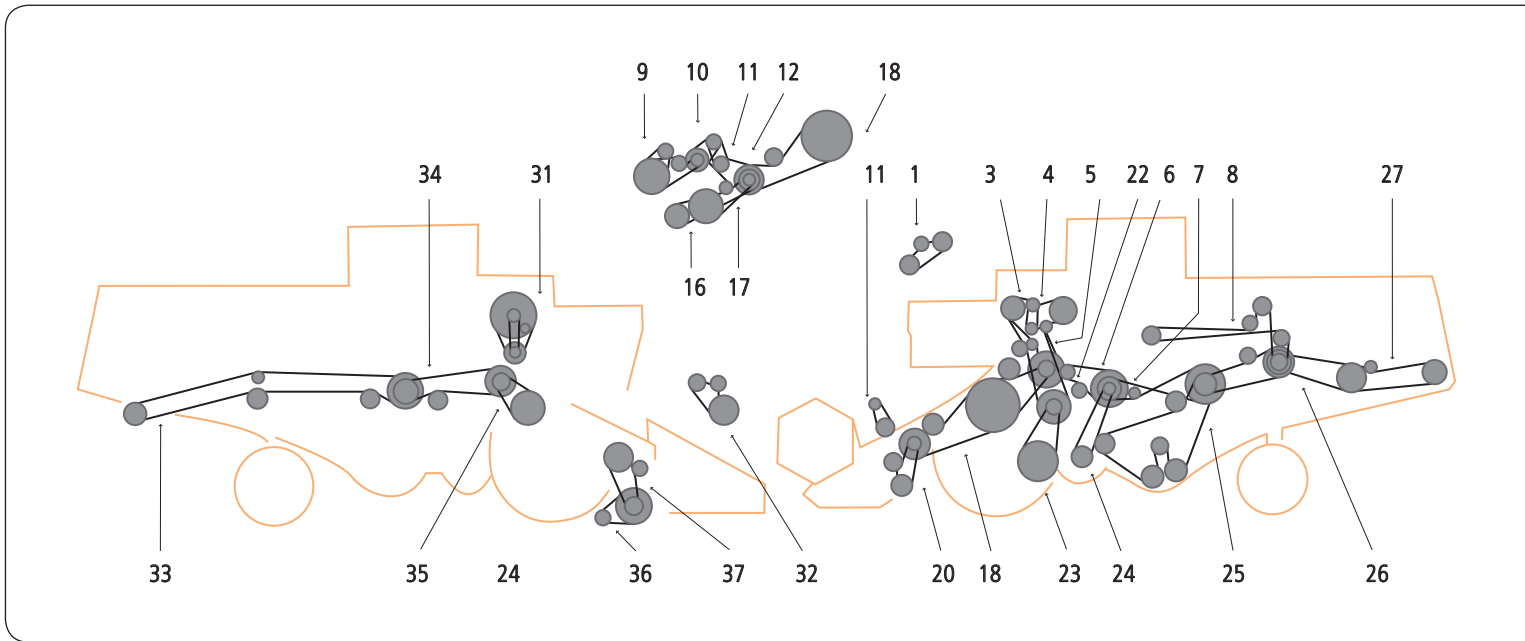

ITEM	APPLICATION	QUANTITY OF V-BELTS IN DRIVE	OE PART NUMBER	COMMENT
1		1	673625.0	
2	HYDRAULIC PUMP	1	767057.1	
3		1	621903.0	
4	DISCHARGE AUGER	1	673614.0	
5	TRACTION DRIVE	1	671012.0	
6		1	603337.0	
6	FAN	1	672358.0	
7	SIEVE DRIVE	1	672359.0	
7		1	603336.0	
8	ELEVATOR	1	629732.1	
9		1	603284.0	
10		1	056961.0	
11	REEL VARIATOR	1	670224.0	X
12		1	056961.0	
16		1	603283.0	
17		1	603048.0	
18		1	603122.0	
20	KNIFE DRIVE	1	629214.0	
21		1	673638.1	X
22		1	629436.0	
23		1	629737.0	
24		1	671209.0	X
25		1	603017.3	
26		1	506671.1	
27		1	623427.1	
31		1	783430.1	
32		1	603247.0	
33		1	061360.0	
34		1	060306.2	
35		1	603015.1	
36		1	629410.0	
37		1	680334.1	

X - not in standard offer

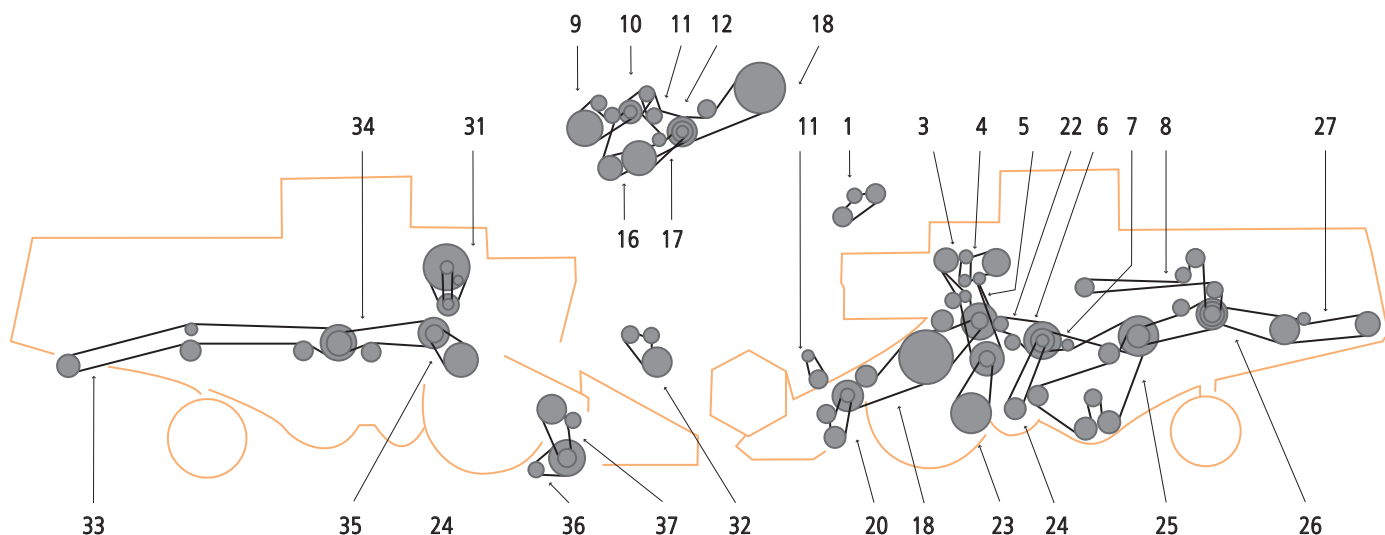

ITEM	APPLICATION	QUANTITY OF V-BELTS IN DRIVE	OE PART NUMBER	COMMENT
1	VARIABLE SPEED REEL	1	670224.0	X
2	CUTTING TABLE CLUTCH	1	560562.0	
3	MAIN DRIVE	1	671012.0	
4	HYDRAULIC PUMP TRACTION DRIVE	1	673625.0	
5	HYDRAULIC PUMP	1	532011.0	
5	HYDRAULIC PUMP	1	633030.0	
5	HYDRAULIC PUMP	1	656028.0	
5	HYDRAULIC PUMP	1	767057.0	
6	GRAIN TANK UNLOADING	1	673614.0	
7	SHAKER SHOE. FANNING MILL	1	672358.0	
8	STRAW WALKER	1	629036.0	
8	STRAW WALKER	1	673601.0	
9	KNIFE DRIVE	1	629214.0	
9	KNIFE DRIVE	1	769202.0	
10	CUTTING TABLE	1	673639.0	
10	CUTTING TABLE	1	778717.0	
11	TRACTION DRIVE	1	720866.0	
12	TRACTION VARI-DRIVE	1	671083.0	X
13	VARIABLE SPEED. FANNING MILL	1	671209.0	X
14	SHAKER SHOE. RETURN AUGER	1	672359.0	
15	GRAIN AUGER	1	673690.0	
16	FEEDER AUGER	1	501925.0	
17	COUNTER SHAFT DRIVE	1	060306.0	
18	AIR INTAKE	1	802931.0	
19	STRAW CHOPPER	1	060949.0	
20	VARIABLE CYLINDER SPEED	1	629035.0	X
20	VARIABLE CYLINDER SPEED	1	671015.0	X
21	THRESHING MACHINE	1	629510.0	
21	THRESHING MACHINE	1	671012.0	

X - not in standard offer

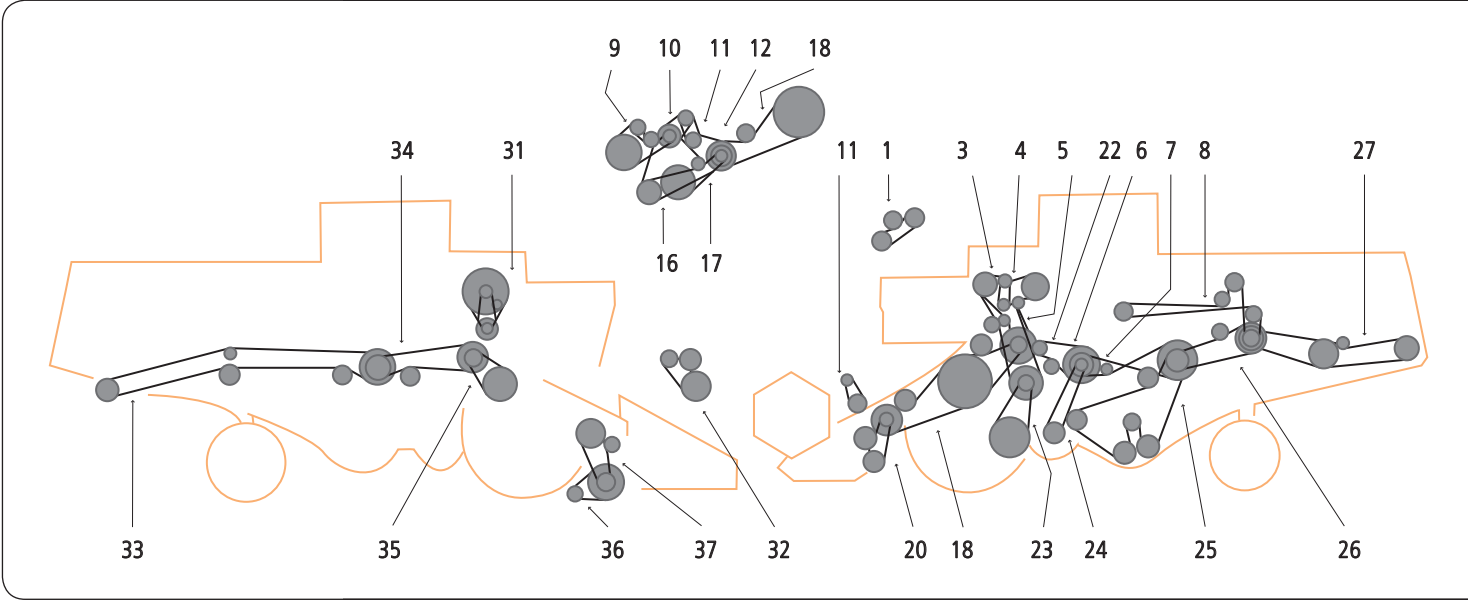

ITEM	APPLICATION	QUANTITY OF V-BELTS IN DRIVE	OE PART NUMBER	COMMENT
1	HYDRAULIC PUMP	1	767057.0	
2		1	621903.0	
3	DISCHARGE AUGER	1	673614.0	
4	TRACTION DRIVE	1	671012.0	
5		1	603337.0	
6		1	603336.0	
7	ELEVATOR	1	629732.0	
10	REEL ELEVATOR	1	670224.0	X
13	KNIFE DRIVE	1	629214.0	
14		1	603122.0	
15		1	673638.0	X
16		1	603427.0	
17		1	603317.0	X
18		1	671209.0	X
19		1	603017.0	
20		1	506671.0	
21		1	635494.0	
24		1	603341.0	
26		1	061361.0	
27	FRONT WHEEL SHAFT	1	060306.0	
28		1	603015.0	
31		1	603247.0	

X - not in standard offer

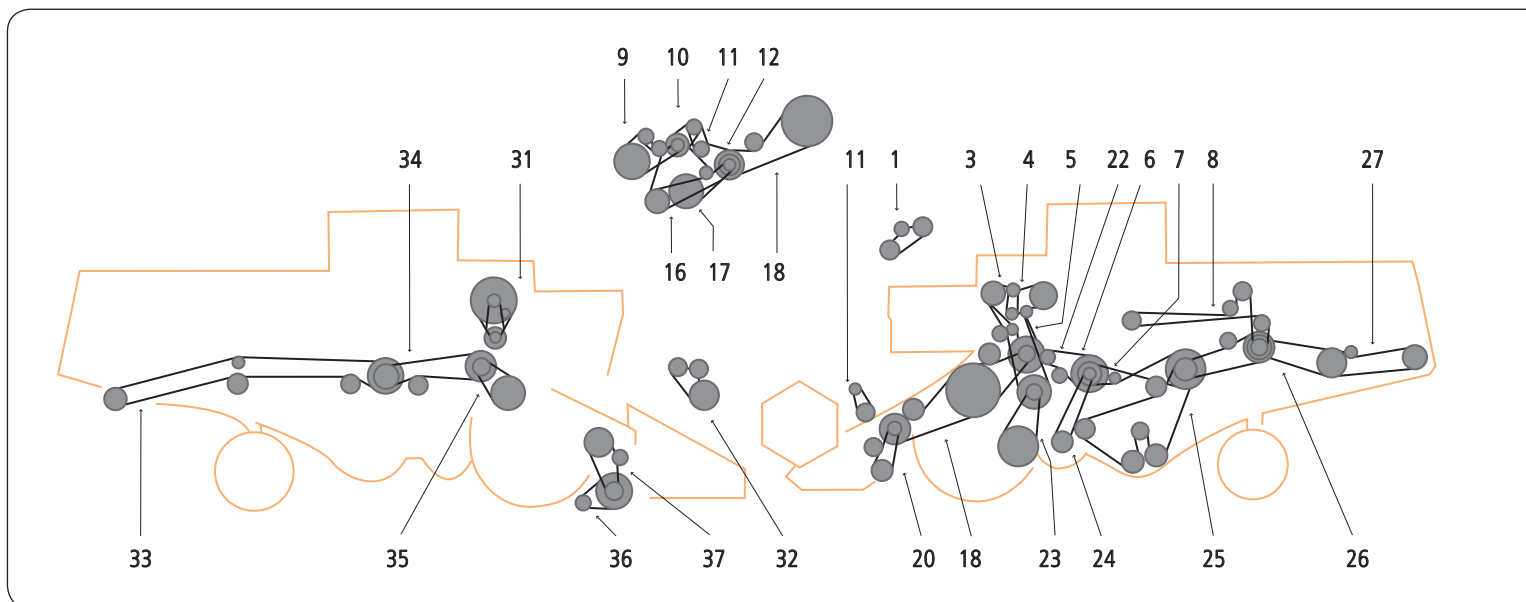

ITEM	APPLICATION	QUANTITY OF V-BELTS IN DRIVE	OE PART NUMBER	COMMENT
1		1	544048.0	
2		1	767057.1	
3		1	629908.1	
4		1	629769.1	
5		1	671012.1	
6		1	603337.0	
7		1	603336.1	
8		1	644447.0	
9		1	635494.0	
10		1	661301.0	
11	FOR CORN	1	061213.0	
11		1	061361.0	
12		1	671209.0	X
13		1	603017.3	
15		1	060306.3	
17		1	506671.2	
18		1	661345.0	
19		1	657793.0	
20		1	628630.0	
21		1	644448.0	
22		1	609823.0	X
23		1	661220.1	

X - not in standard offer

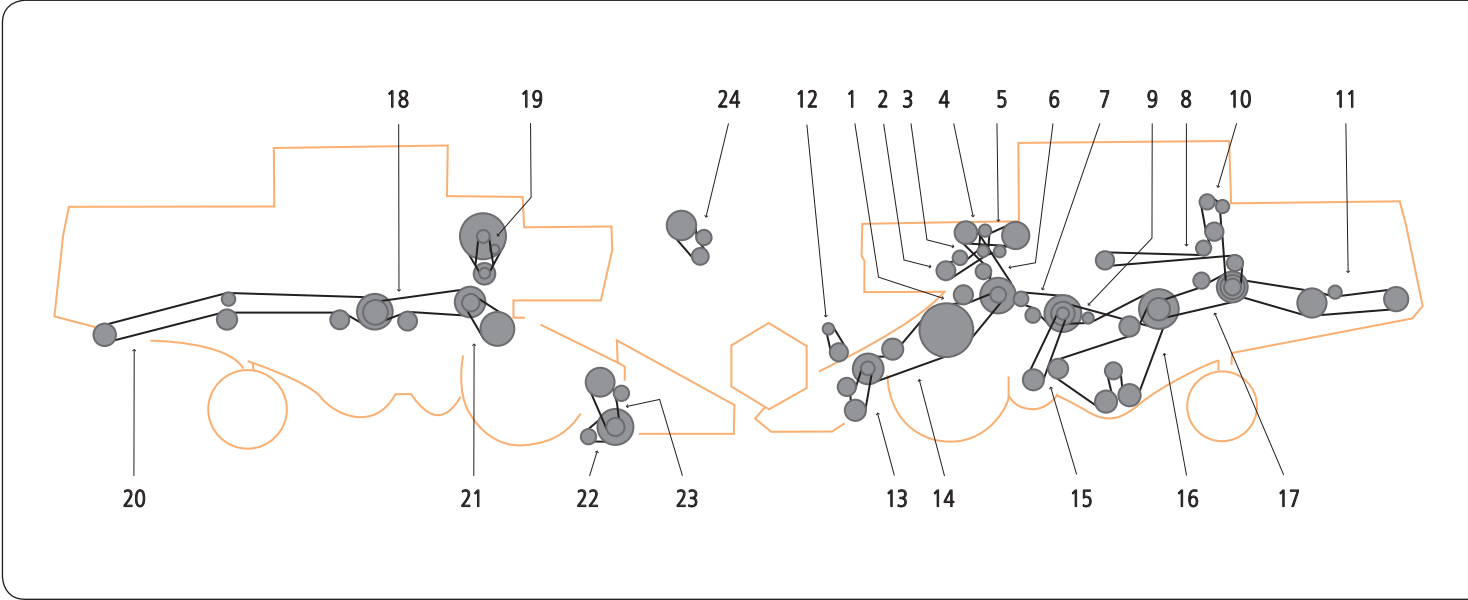

ITEM	APPLICATION	QUANTITY OF V-BELTS IN DRIVE	OE PART NUMBER	COMMENT
2		1	767057.1	
3		1	673625.0	
4		1	621903.0	
5		1	673614.0	
6		1	671012.0	
7		1	603337.0	
8		1	629732.1	
9		1	603336.0	
10		1	802931.0	
11		1	623427.1	
12		1	670224.0	X
13		1	629214.0	
14		1	603122.0	
15		1	671209.0	X
16		1	603017.3	
17		1	506671.1	
18		1	061306.2	
19		1	603341.0	
20		1	061360.0	
21		1	603015.1	
22		1	629410.0	
23		1	680334.1	
24		1	603247.0	

X - not in standard offer

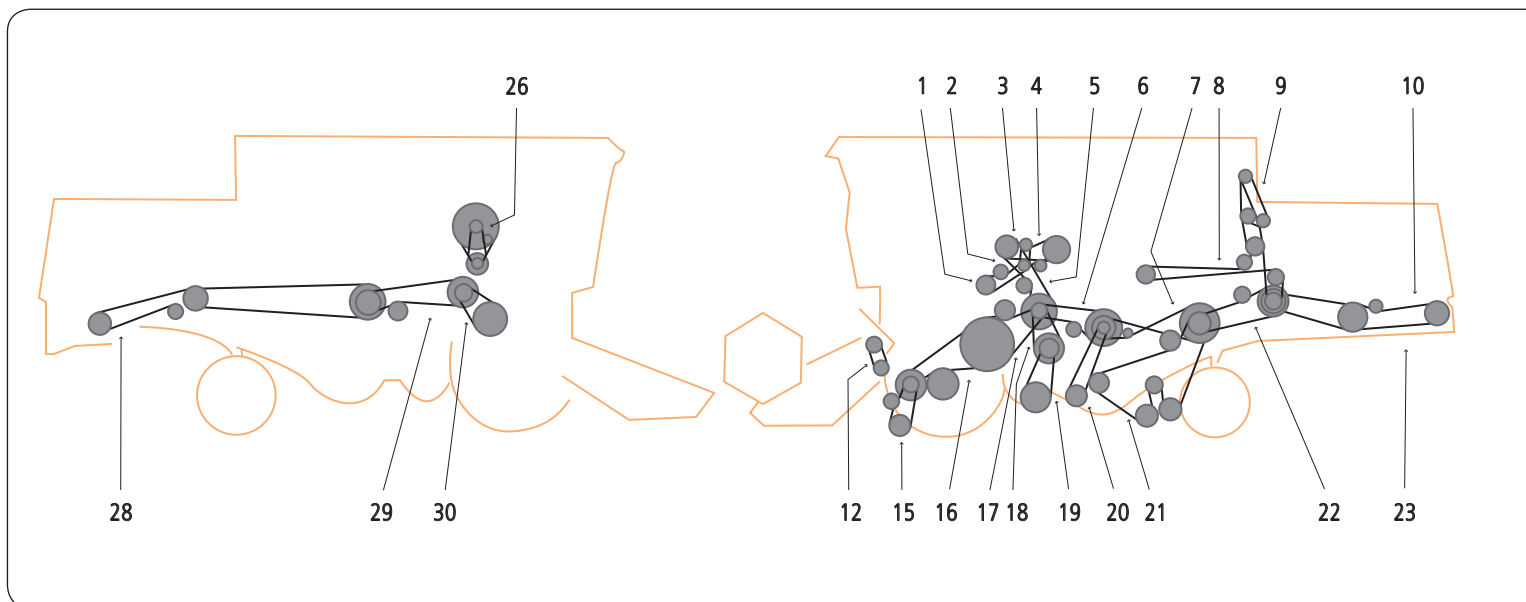

ITEM	APPLICATION	QUANTITY OF V-BELTS IN DRIVE	OE PART NUMBER	COMMENT
1		1	544048.0	
2		1	767057.1	
3		1	629908.1	
4		1	629769.1	
5		1	661458.0	
6		1	603337.0	
7		1	603336.1	
9		1	802931.0	
10		1	623427.1	
11		1	755070.1	
12		1	066034.0	
12		1	785341.0	
14		1	061214.0	
15		1	671209.0	X
16		1	603017.3	
18		1	060306.3	
20		1	506671.2	
21		1	661345.0	
22		1	657793.0	
23		1	644418.0	
24		1	644448.0	
25		1	609823.0	X
26		1	661220.1	

X - not in standard offer

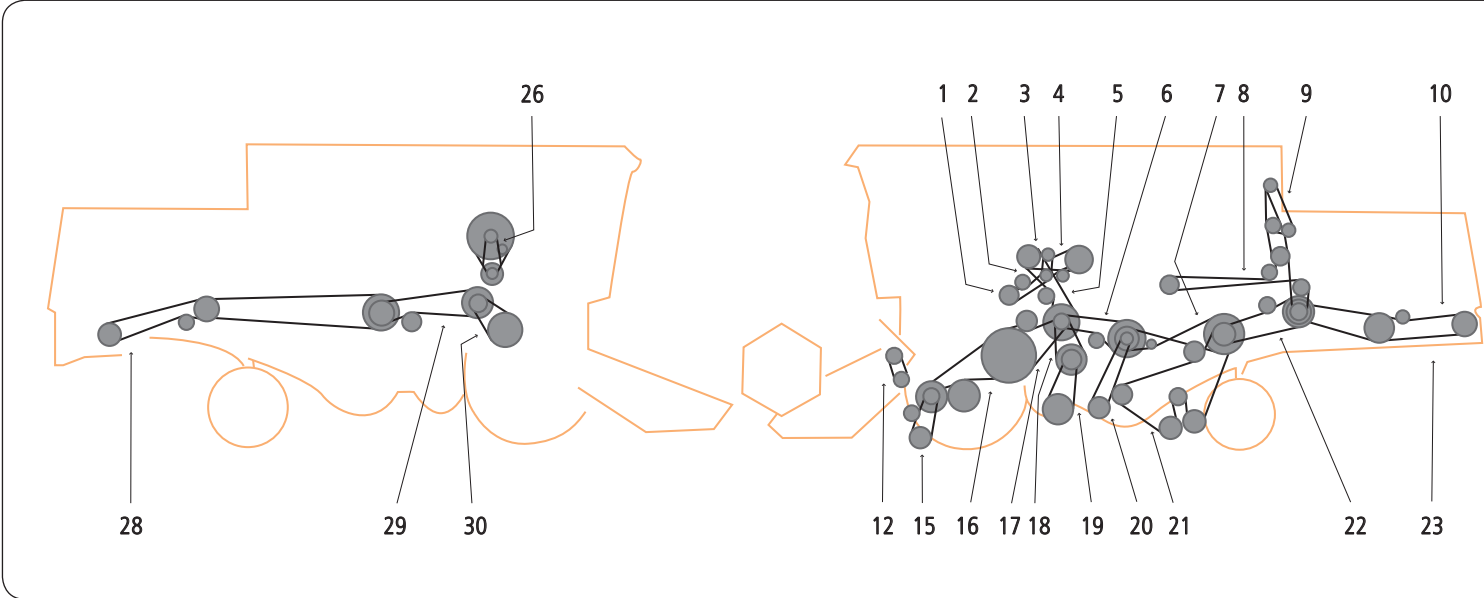

ITEM	APPLICATION	QUANTITY OF V-BELTS IN DRIVE	OE PART NUMBER	COMMENT
1	(MERCEDES OM 352A)	1	629001.0	
1	(MERCEDES OM 360)	1	673625.0	
2	(MERCEDES OM 352A + PERKINS T63544)	1	603378.0	
2	(MERCEDES OM 360)	1	767057.0	
3		1	629908.0	
4		1	673614.0	
5	(MERCEDES OM 360)	1	671012.0	
5	(MERCEDES OM 352A + PERKINS T63544)	1	629000.0	
6		1	603337.0	
7		1	603336.0	
8		1	629732.0	
9		1	802931.0	
12		1	670224.0	X
15		1	713506.0	
16	SHAFT BASE 1177 MM	1	629836.0	
16	SHAFT BASE 1463 MM	1	061872.0	
17		1	673638.0	X
18	MECH. DRIVE	1	609822.0	
19	MECH. DRIVE	1	609823.0	X
20		1	671209.0	X
21		1	603017.0	
22		1	506671.0	
23		1	623427.0	
26		1	603341.0	
28	FOR MAIZE STRAW CHOPPER	1	061214.0	
28	FOR STRAW CHOPPER	1	061360.0	
29	FOR STRAW CHOPPER	1	060306.0	
30	CYLINDER BY 650-1500 RPM	1	628630.0	
30	CYLINDER BY 500-1400 RPM	1	644177.0	X

X - not in standard offer

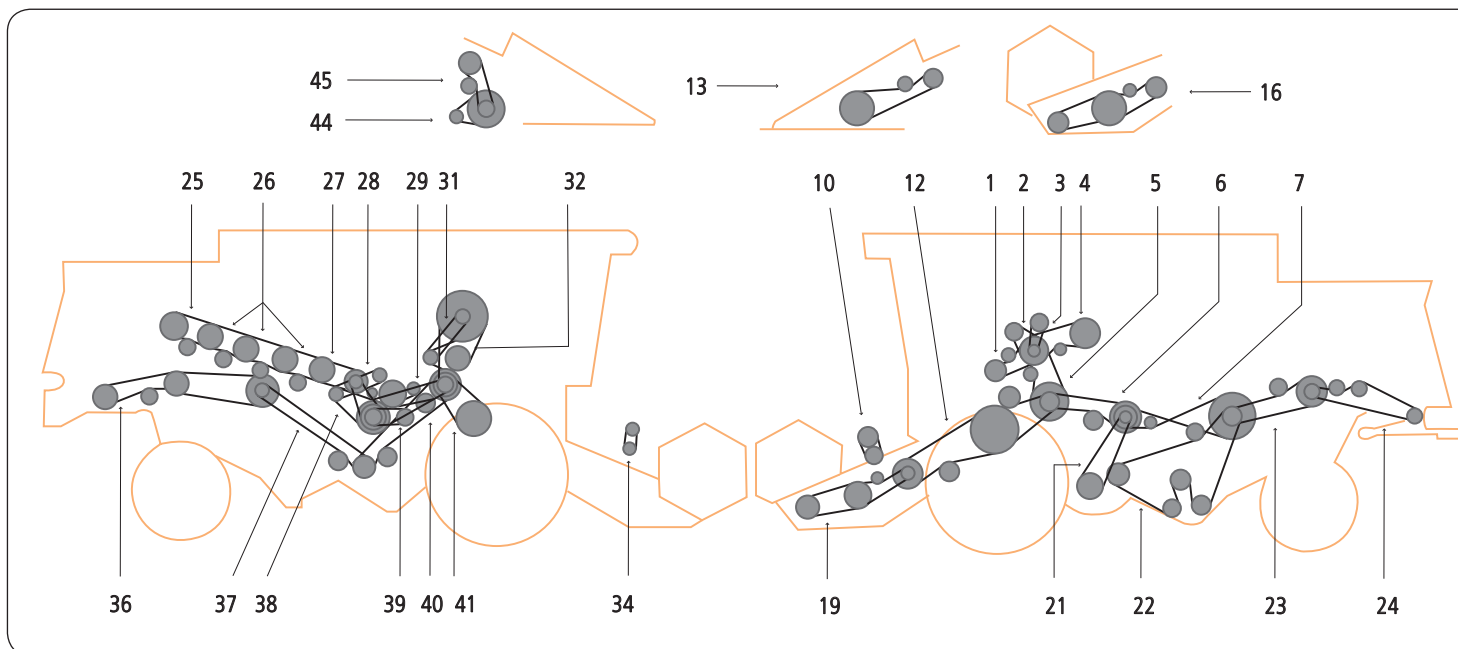

ITEM	APPLICATION	QUANTITY OF V-BELTS IN DRIVE	OE PART NUMBER	COMMENT
1	VARIABLE SPEED REEL	1	670224.0	X
2	CUTTING TABLE	1	672353.0	
3	THRESHING MACHINE	1	629000.0	
4	HYDRAULIC PUMP TRACTION DRIVE	1	629001.0	
5	HYDRAULIC PUMP	1	629002.0	
6	GRAIN TANK	1	673614.0	
7	SHAKER SHOE. FANNING MILL	1	672358.0	
8	STRAW WALKER	1	629036.0	
9	KNIFE DRIVE	1	629214.0	
9	KNIFE DRIVE	1	769202.0	
10	VARIABLE SPEED FAN	1	671209.0	X
11	SHAKER SHOE. RETURN AUGER	1	672359.0	
12	GRAIN AUGER	1	629081.0	
13	ELEVATOR	1	629732.0	
14	FEEDER ELEVATOR	1	501925.0	
15	COUNTERSHAFT DRIVE	1	060306.0	
16	AIR INTAKE	1	802931.0	
17	STRAW CHOPPER	1	061253.0	
18	CYLINDER VARI-DRIVE	1	629035.0	X
19	THRESHING MACHINE	1	629510.0	

X - not in standard offer

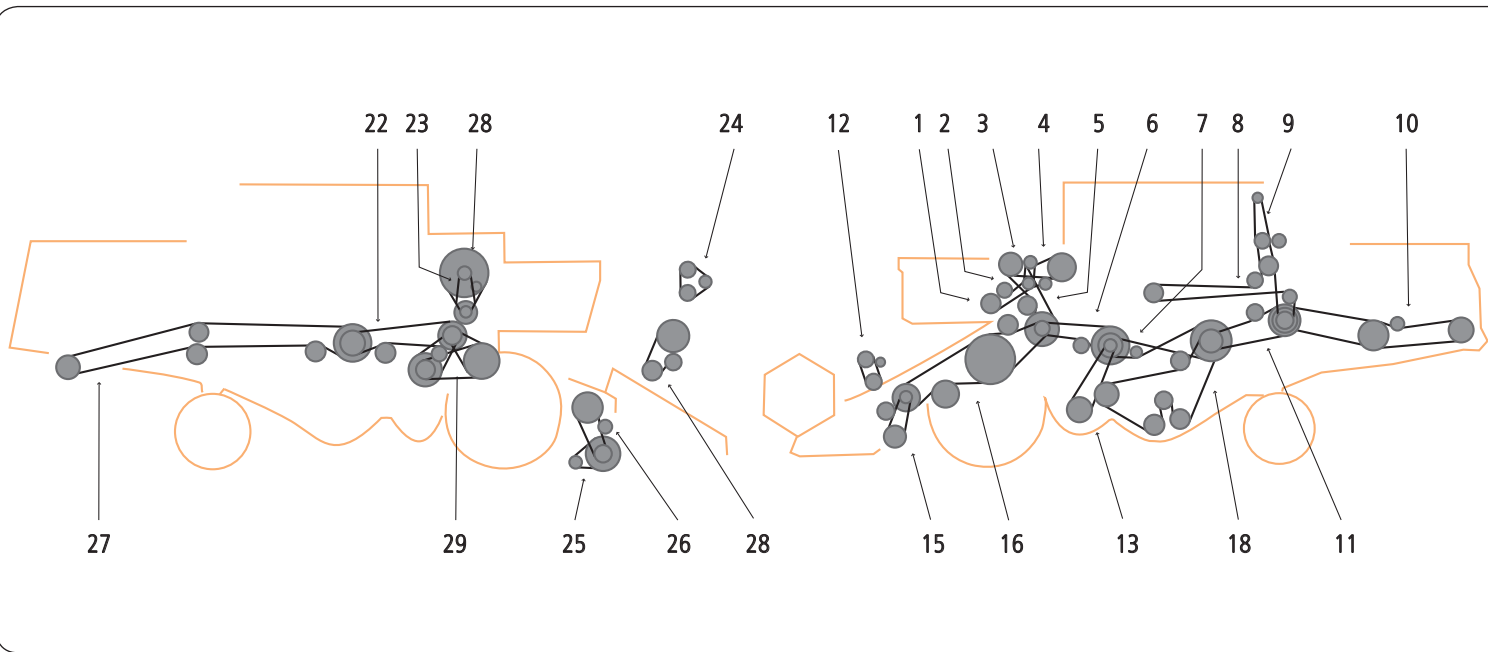

ITEM	APPLICATION	QUANTITY OF V-BELTS IN DRIVE	OE PART NUMBER	COMMENT
1	HYDRAULIC PUMP (OM 360)	1	629001.0	
1	MAIN (OM 401)	1	629279.0	
2	(OM 360)	1	603378.0	
2	(OM 401)	1	689175.0	
3		1	621903.0	
4	GRAIN TANK (OM 360)	1	673614.0	
4	GRAIN TANK (OM 401)	1	672351.0	
5	MAIN/DRUM	1	629000.0	
6		1	603337.0	
7	RETURNS AUGER	1	603336.0	
8	ELEVATOR	1	629732.1	
9		1	640653.0	
10		1	623427.1	
11	STRAW WALKER	1	506671.1	
12	REEL VARI	1	670224.0	X
13		1	603380.0	
15	KNIFE	1	629214.0	
16	TABLE	1	629441.0	
18	SIEVE PAN FROM NO 9000439	1	609762.0	
18	SIEVE PAN TO NO 9000438	1	603033.0	
22	COUNTERSHAFT	1	060306.2	
23		1	603341.0	
24	ENGINE (OM 401)	1	133528.0	
24	ENGINE (OM 401)	1	133549.0	
24	ENGINE (OM 360)	1	685693.0	
25		1	629410.0	
26		1	680334.1	
27	STRAW CHOPPER	1	061360.0	
28	DRUM	1	629366.1	
28	DRUM	1	629035.0	X
29	CYLINDER	1	603354.0	

X - not in standard offer

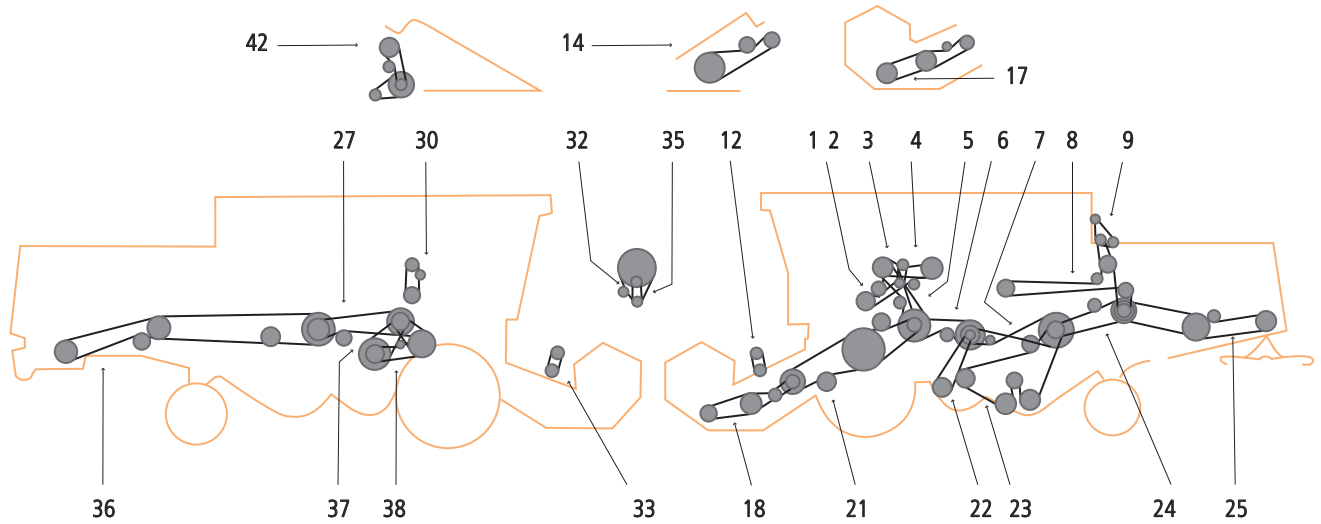

ITEM	APPLICATION	QUANTITY OF V-BELTS IN DRIVE	OE PART NUMBER	COMMENT
1	WITH MERC. OM 421	1	629279.0	
1	WITH MERC. OM 366 LA	1	644405.1	
1	WITH MERC. OM 441 A	1	661092.1	
2		1	689175.0	
3		1	629908.0	
3	WITH VAR. 7705	1	661114.0	
4	WITH VAR. 7605	1	660409.0	
4	WITH VAR. 7705	1	661093.0	
4	TO NO 09403057	1	629763.0	
5	TO NO 09403057	1	629000.0	
5	FROM NO 09403058	1	644404.1	
6		1	603337.0	
7		1	603336.0	
8	TO NO 09404032	1	629732.0	
8	FROM NO 09404033	1	644447.0	
9	NOT SERIE MA	1	640653.0	
12	WITH 3.9 M - 5.1 M	1	670224.0	X
14	FOR MAIZE PICKER	1	692149.0	
14	FOR MAIZE PICKER	1	692150.0	
17	WITH 6.0 M - 9.0 M	1	671013.0	
19	STRAW WALKER	1	713506.0	
21	SHAFT 1177 MM	1	629441.0	
21	SHAFT 1463 MM TO NO 09404032	1	603017.0	
21	SHAFT 1306 MM TO NO 09404032	1	603430.0	
21	SHAFT 1306 MM FROM NO 09404033	1	644419.0	
21	SHAFT 1463 MM FROM NO 0940433	1	661301.0	
22	COUNTERSHAFT DRIVE	1	603380.0	
23		1	609762.0	
24		1	506671.0	
25		1	623427.0	
27	STRAW CHOPPER	1	060306.0	
30		1	603341.0	
30		1	783430.1	
32	FROM NO 09405335	1	661345.0	

ITEM	APPLICATION	QUANTITY OF V-BELTS IN DRIVE	OE PART NUMBER	COMMENT
32	WITH RABA - ENGINE	1	783876.0	
32	TO NO 09405334	1	821734.2	
33	WITH 6.0 M - 9.0 M	1	670224.0	X
35	WITH RABA - ENGINE	1	629764.0	
35	WITH OM 366 LA	1	657793.0	
35	WITH OM 366 LA	1	661244.0	
35	WITH MERC. OM 441 A	1	661245.0	
35	WITH 6.0 M - 9.0 M	1	670229.2	X
36	CHOPPER MAIZE	1	061214.0	
36	CHOPPER GRAIN FROM NO 09403058	1	061353.0	
36	CHOPPER GRAIN TO NO 09403057	1	061360.0	
37	FROM NO 09403058	1	609823.0	X
37	TO NO 09403057	1	629035.0	X
38	VAR. 7818	1	661298.0	
38	WITH N 510 - 1220 MIN. -1	1	629510.1	
38	WITH N 650 - 1500 MIN. -1	1	603354.0	
38	VAR. 7693 / VAR. 7716	1	661220.0	
41		1	695610.0	X
42		1	680334.0	
43	FOR AIR EXHAUST	1	644448.0	

X - not in standard offer

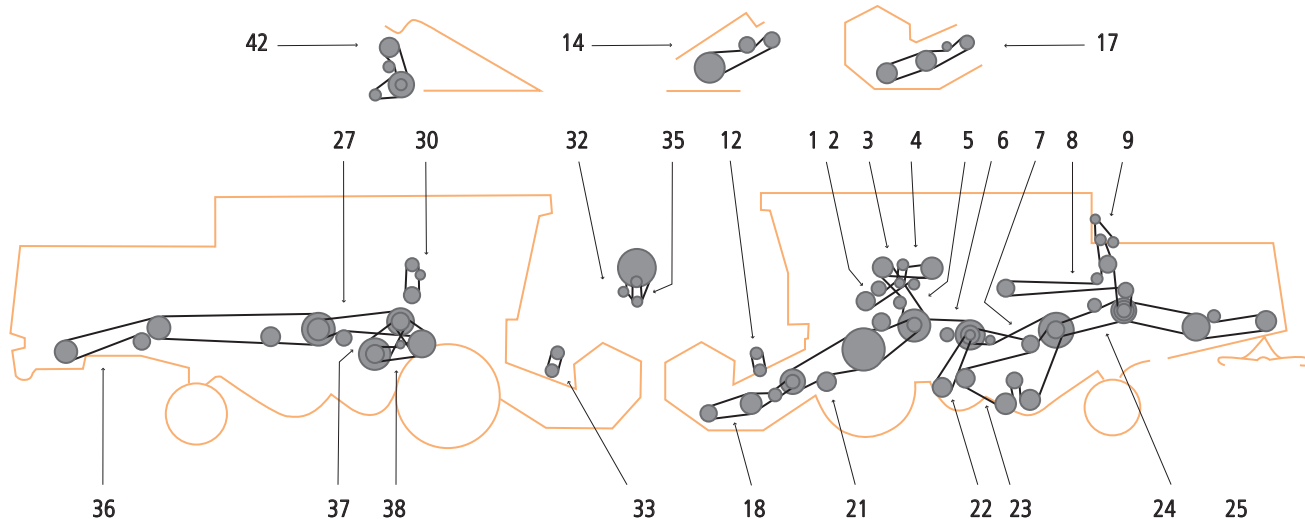

ITEM	APPLICATION	QUANTITY OF V-BELTS IN DRIVE	OE PART NUMBER	COMMENT
1		1	689175.0	
2		1	629908.0	
3		1	629769.0	
4	MAIN/DRUM	1	629000.0	
5		1	603337.0	
6	RETURNS AUGER	1	603336.0	
7	ELEVATOR	1	629732.0	
7	FROM NO 09404033	1	644447.0	
8		1	640653.0	
11	WITH 3.9 M - 5.1 M	1	670224.0	X
13	FOR MAIZE PICKER	1	692149.0	
13	FOR MAIZE PICKER	1	692150.0	
16	WITH 6.0 M - 9.0 M	1	671013.0	
18	WITH 3.9 M - 5.1 M	1	713506.0	
20	SHAFT 1306 MM	1	603290.0	
20	SHAFT 1177 MM	1	629836.0	
21	TABLE CLUTCH	1	673638.0	X
22		1	609822.0	
23		1	609823.0	X
24		1	603380.0	
25		1	609762.0	
26		1	506671.0	
27		1	623427.0	
29	COUNTERSHAFT	1	060306.0	
32	TO NO 09400750	1	603341.0	
32	FROM NO 09400751	1	783430.1	
34	WITH 6.0 M - 9.0 M	1	670224.0	X
36	CHOPPER MAIZE	1	061214.0	
36	CHOPPER GRAIN FROM NO 09403058	1	061353.0	
36	CHOPPER GRAIN TO NO 09403057	1	061360.0	
37		1	628630.0	
40		1	695610.0	X
41		1	680334.0	
42	WITH TWO-STAGE DRIVE	1	661220.0	

X - not in standard offer

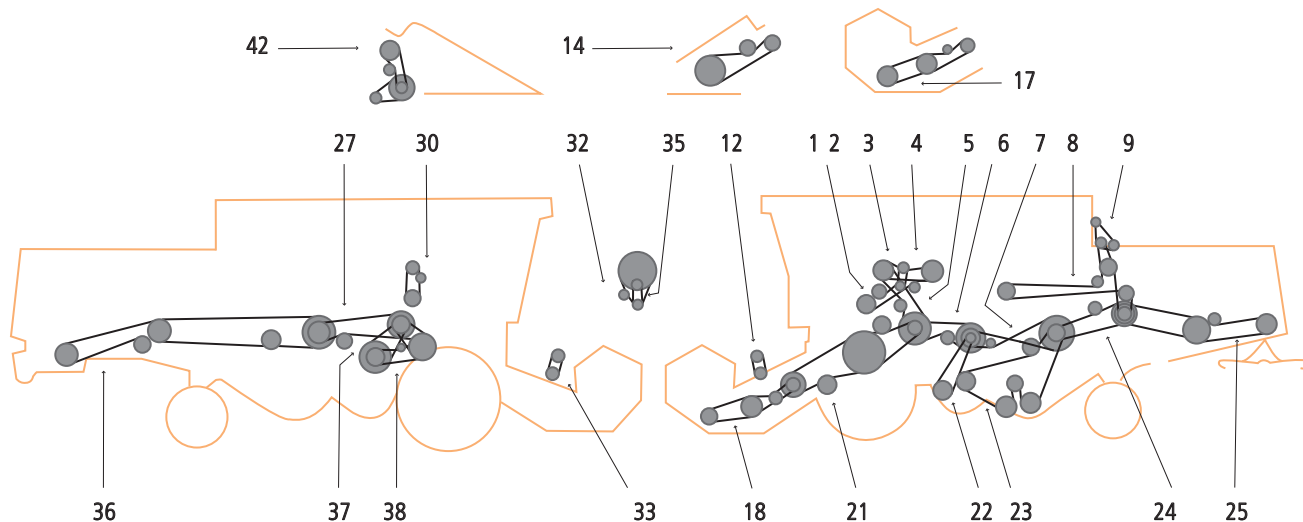

ITEM	APPLICATION	QUANTITY OF V-BELTS IN DRIVE	OE PART NUMBER	COMMENT
1		1	544049.0	
2		1	767057.1	
3		1	629908.1	
4		1	660409.0	
5		1	644404.1	
6		1	603337.0	
7		1	644141.1	
8		1	644447.0	
9		1	623427.1	
10		1	755070.1	
11		1	066034.0	
11		1	785341.0	
12		1	661337.0	
13		1	061214.0	
13		1	061353.1	
14		1	603380.1	
15		1	609762.0	
17		1	060306.3	
19		1	506671.2	
20		1	661345.0	
21	MERCEDES OM 366L	1	661244.0	
21	MERCEDES OM 441	1	661245.0	
22		1	644448.0	
23		1	609823.0	X
24		1	661220.1	
24		1	661298.0	

X - not in standard offer

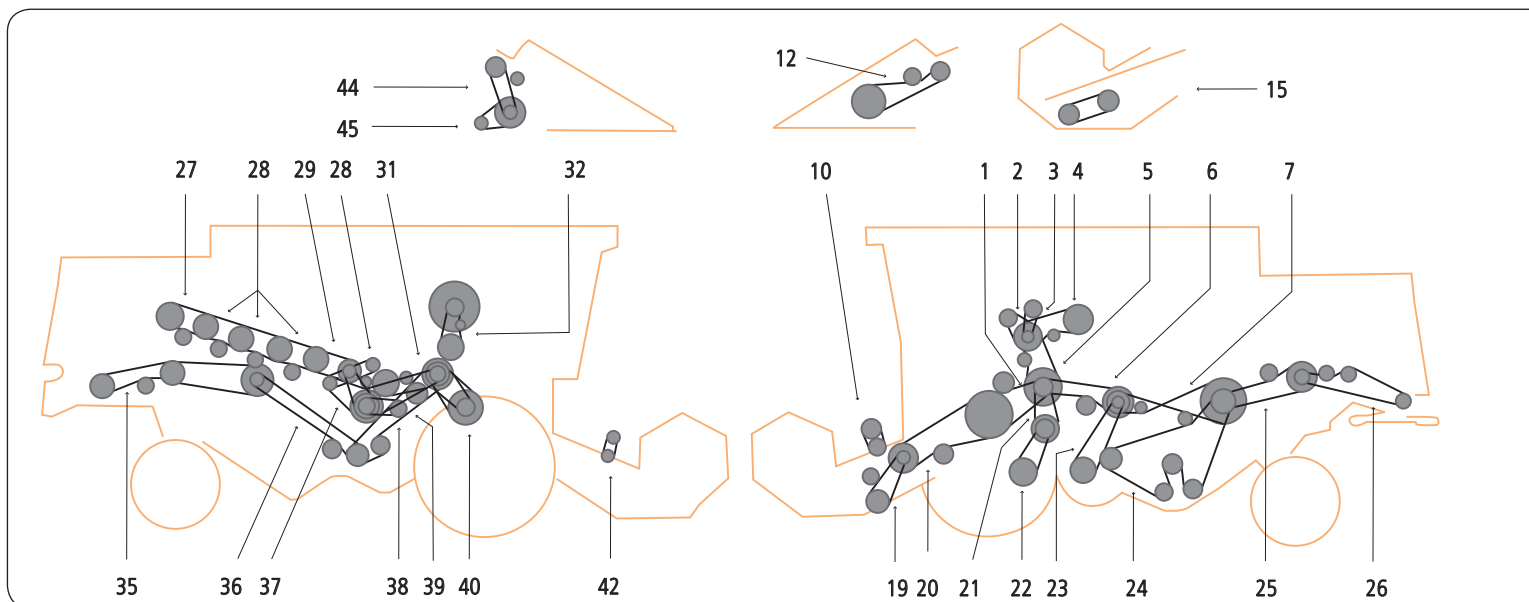

ITEM	APPLICATION	QUANTITY OF V-BELTS IN DRIVE	OE PART NUMBER	COMMENT
1		1	673638.1	X
2		1	689175.0	
3		1	629908.1	
4		1	629769.0	
5		1	629000.0	
6		1	603337.0	
7		1	644141.0	
12	FOR MAIZE PICKER	1	692149.0	
12	FOR MAIZE PICKER	1	692150.0	
15	FROM 6.0 M CUTTING TABLE	1	671013.1	
15	BY SOJA CUTTING TABLE	1	644209.0	
19	TO 5.1 M CUTTING TABLE	1	629214.1	
20		1	629836.0	
21		1	609822.0	
22		1	609823.0	X
23		1	603380.0	
24		1	609762.0	
25		1	506671.1	
26		1	640653.1	
27		1	644014.1	
28		1	644015.0	
29		1	644016.1	
31		1	064168.2	
35	FOR MAIZE	1	061872.0	
35	FOR GRAIN	1	061701.1	
36	FOR STRAW CHOPPER	1	061700.0	
37		1	603247.1	
38	FOR STRAW CHOPPER	1	061700.0	
39		1	644014.1	
40	CYLINDER BY 650-1500 RPM	1	603015.1	
40	CYLINDER BY 500-1400 RPM	1	644177.0	X
42	FROM 6.0 M CUTTING TABLE	1	670224.0	X
44		1	680334.1	
45		1	629410.0	

X - not in standard offer

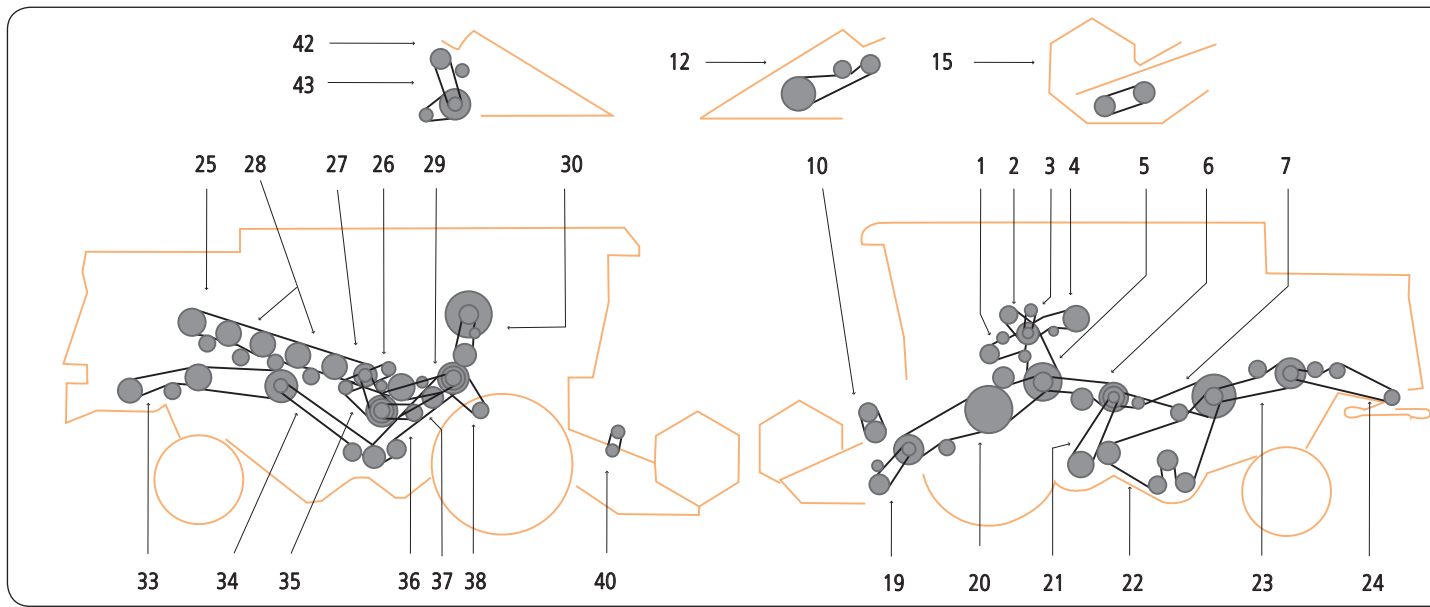

ITEM	APPLICATION	QUANTITY OF V-BELTS IN DRIVE	OE PART NUMBER	COMMENT
1		1	629279.0	
2		1	629002.1	
3	TO NO 14200046	1	621903.1	
3	FROM NO 14200047	1	629908.1	
4		1	629763.0	
5		1	629000.0	
6		1	603337.0	
7		1	644141.0	
10	TO 5.7 M CUTTING TABLE	1	670224.0	X
12	FOR MAIZE PICKER	1	692149.0	
12	FOR MAIZE PICKER	1	692150.0	
15	FROM 6.0 M CUTTING TABLE	1	671013.1	
15	BY SOJA CUTTING TABLE	1	644209.0	
19	TO 5.7 M CUTTING TABLE	1	629214.1	
20		1	603017.3	
21		1	603380.0	
22		1	609762.0	
23	FOR STRAW DISTRIBUTOR	1	506671.1	
24	FOR STRAW DISTRIBUTOR	1	640653.1	
25		1	644014.0	
26		1	644015.1	
27		1	644016.1	
29		1	064168.2	
30	TO NO 14200176	1	603341.0	
30	FROM NO 14200177	1	233843.1	
33	FOR MAIZE	1	061872.0	
33	FOR GRAIN	1	061701.1	
34	FOR STRAW CHOPPER	1	061700.0	
35		1	603247.1	
36	FOR STRAW CHOPPER	1	061700.0	
37		1	344014.1	
38	CYLINDER BY 650-1500 RPM	1	603015.1	
38	CYLINDER BY 500-1400 RPM	1	644177.0	X
40	FROM 6.0 M CUTTING TABLE	1	670224.0	X
42		1	680334.1	
43		1	629410.0	

X - not in standard offer

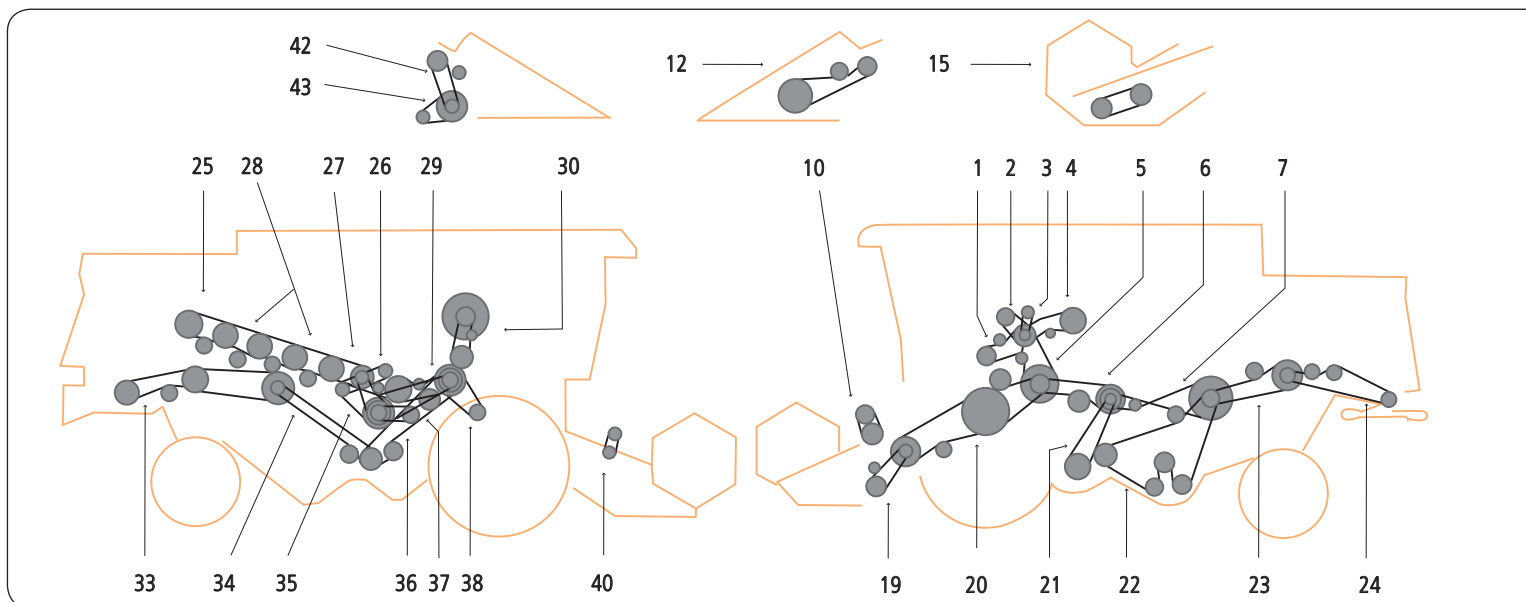

ITEM	APPLICATION	QUANTITY OF V-BELTS IN DRIVE	OE PART NUMBER	COMMENT
1		1	629763.0	
1		1	644017.0	
2		1	629002.1	
3		1	629908.1	
5		1	644018.0	
6		1	603337.0	
7		1	644141.0	
10	TO 5.1 M CUTTING TABLE	1	670224.0	X
12	FOR MAIZE PICKER	1	692149.0	
12	FOR MAIZE PICKER	1	692150.0	
15	FROM 6.0 M CUTTING TABLE	1	671013.1	
15	BY SOJA CUTTING TABLE	1	644209.0	
19	TO 5.1 M CUTTING TABLE	1	629214.1	
20		1	603017.3	
21		1	603380.0	
22		1	609762.0	
23	FOR STRAW DISTRIBUTOR	1	506671.1	
24	FOR STRAW DISTRIBUTOR	1	640653.1	
25		1	644014.1	
26		1	644015.1	
27		1	644016.1	
29		1	064168.2	
30		1	233843.1	
33	FOR MAIZE	1	061872.0	
33	FOR GRAIN	1	061701.1	
34	FOR STRAW CHOPPER	1	061700.0	
35		1	603247.1	
36	FOR STRAW CHOPPER	1	061700.0	
37		1	644014.1	
38	CYLINDER BY 650-1550 RPM	1	603015.1	
38	CYLINDER BY 500-1400 RPM	1	644177.0	X
40	FROM 6.0 M CUTTING TABLE	1	670224.0	X
42		1	680334.1	
43		1	629410.0	

X - not in standard offer

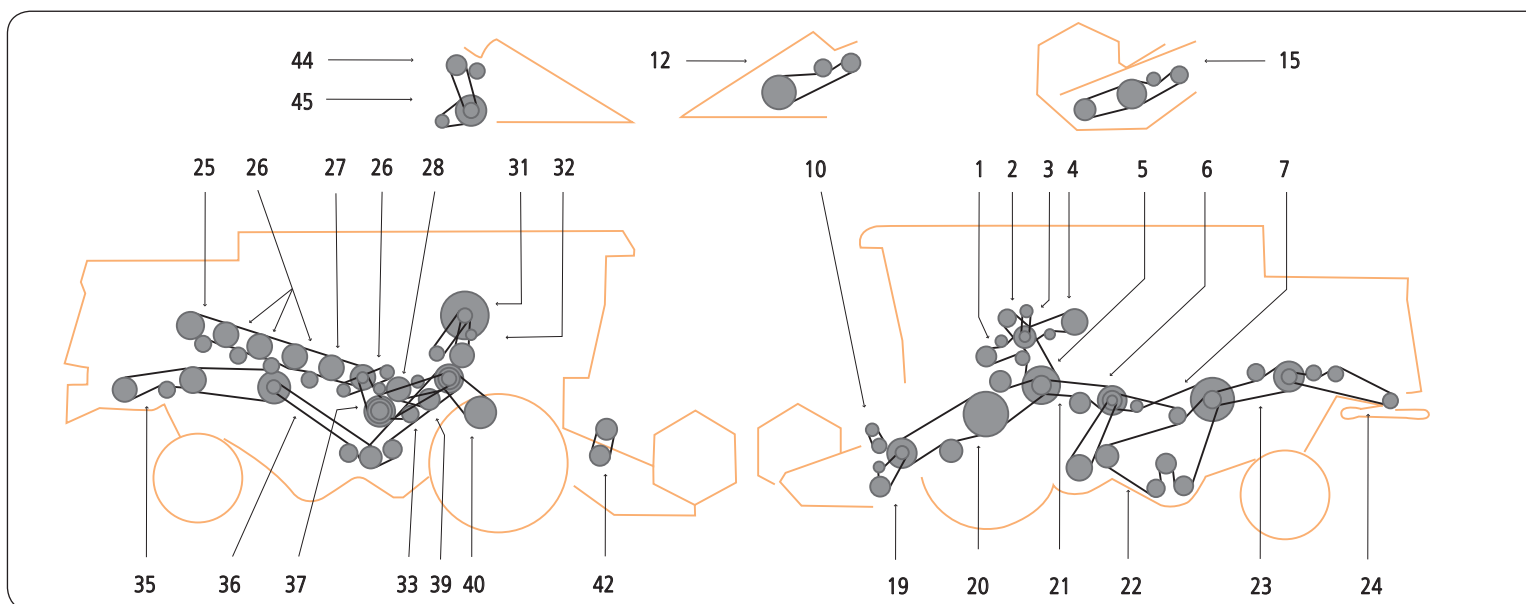

ITEM	APPLICATION	QUANTITY OF V-BELTS IN DRIVE	OE PART NUMBER	COMMENT
1	HYDRAULIC PUMP	1	644017.0	
2	HYDRAULIC PUMP - TO NO 14400299	1	689175.0	
2	HYDRAULIC PUMP FROM NO 14400300	1	629002.1	
3	TO NO 14400199	1	621903.1	
3	FROM NO 14400200	1	629908.1	
4	GRAIN TANK	1	629763.0	
5	MAIN DRIVE	1	644018.0	
6		1	603337.0	
7	RETURNS AUGER	1	603336.0	
10	REEL VARI - TO 5.7 M CUTTING TABLE	1	670224.0	X
12	FOR MAIZE PICKER	1	692149.0	
12	FOR MAIZE PICKER	1	692150.0	
15	FROM 6.0 M CUTTING TABLE	1	671013.1	
15	BY SOJA CUTTING TABLE	1	644209.0	
19	KNIFE TO 5.7 M CUTTING TABLE	1	629214.1	
20	TABLE - TO NO 14400124	1	629441.0	
20	TABLE FROM NO 14400125	1	603017.3	
21		1	603380.0	
22	SIEVE PAN	1	609762.0	
23	STRAW WALKER	1	506671.1	
24		1	640653.1	
25		1	644014.1	
26	ROLLER	1	644015.1	
27	ROLLER	1	644016.1	
28	INTER MED	1	064168.2	
31	SCREEN - TO NO 14400299	1	233843.1	
31	SCREEN - FROM NO 14400300	1	644267.0	
32	FROM NO 14400300	1	633030.2	
35	FOR MAIZE	1	061872.0	
35	FOR GRAIN	1	061701.1	
36	FOR STRAW CHOPPER	1	061700.0	
37	STRAW WALKER	1	603247.1	
38	FOR STRAW CHOPPER	1	061700.0	
39		1	644014.1	
40	CYLINDER BY 650-1500 RPM	1	603015.1	
40	CYLINDER BY 500-1400 RPM	1	644177.0	X
42	FROM 6.0 M CUTTING TABLE	1	670224.0	X
44		1	680334.1	
45		1	629410.0	

X - not in standard offer

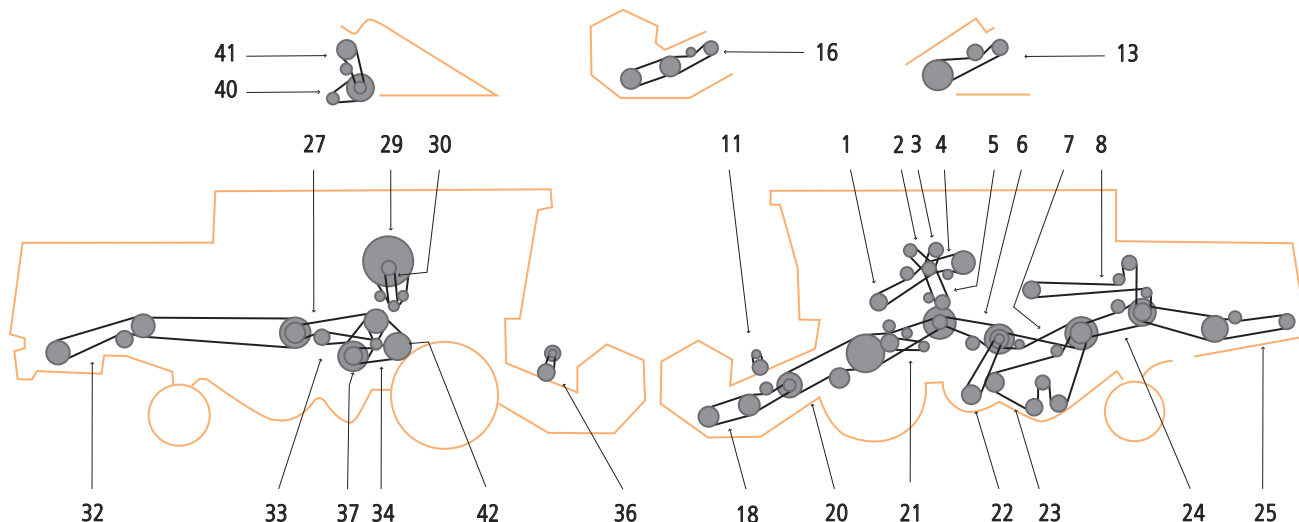

ITEM	APPLICATION	QUANTITY OF V-BELTS IN DRIVE	OE PART NUMBER	COMMENT
0	WITH TWO-STAGE DRIVE	1	609823.0	X
0	WITH TWO-STAGE DRIVE	1	661220.0	
1	TRAVEL DRIVE	1	661362.1	
2	HYDRAULIC PUMP	1	767057.1	
3	AIR CONDITIONING	1	629908.1	
4	TANK UNLOADING	1	629769.0	
5	THRESHING MACHINE	1	661458.0	
6	COUNTERSHAFT	1	603337.0	
7	BY DOM. 204 MEGA	1	644141.1	
7	BY DOM. 203 MEGA	1	603336.1	
11	REEL BY 3.9 M - 5.1 M CUTTING TABLE	1	670224.1	X
13	FOR MAIZE PICKER	1	692149.0	
13	FOR MAIZE PICKER	1	692150.0	
13	FOR MULTIMASTER	1	629142.0	
16	BY 6.0 - 7.5 M CUTTING TABLE	1	671013.1	
18	KNIFE DRIVE 3.9 - 5.1 M CUTTING TABLE	1	713506.2	
20	SHAFT 1306 MM	1	661337.0	
20	SHAFT 1463 MM	1	661378.1	
21	ACCELERATOR	1	661031.0	
22	BLOWER - DOM. 203 MEGA	1	671209.0	X
22	BLOWER - DOM. 204 MEGA	1	603380.1	
23	SHAKER SHOE - DOM. 204 MEGA	1	609762.0	
23	SHAKER SHOE - 203 MEGA	1	603017.3	
24	STRAW WALKER	1	506671.2	
25	STRAW DISTRIBUTOR	1	623427.1	
27	STRAW SHOPPER	1	060306.2	
29	COOLER	1	661345.0	
30	COUNTERSHAFT	1	657793.0	
32	STRAW CHOPPER FOR MAIZE	1	061214.0	
32	STRAW CHOPPER FOR GRAIN	1	061360.0	
33	DOM. 204 MEGA BY 650-1500 RPM	1	609823.0	X
34	DOM. 204 MEGA BY 650-1500 RPM	1	661220.0	
35	REEL BY 6.0 M - 7.5 M CUTTING TABLE	1	670224.1	X
37	AIR EXHAUST	1	644448.0	
40	CHOPPER	1	695610.0	X
41	CHOPPER	1	680334.1	
42	DOM. 203 MEGA BY 650-1500 RPM	1	644418.0	
43	WITH MERCEDES OM 366 LA ENGINE	1	133635.0	
43	WITH MERCEDES OM 366 A ENGINE	1	133630.0	

X - not in standard offer

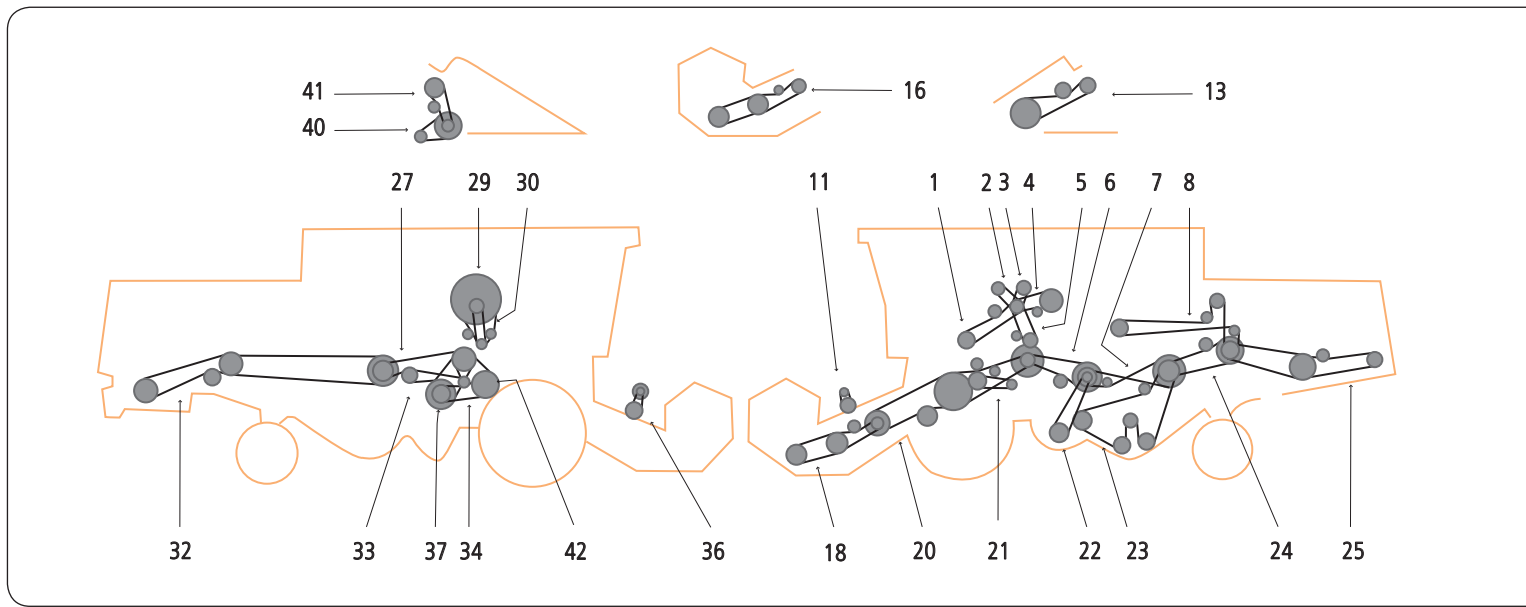

ITEM	APPLICATION	QUANTITY OF V-BELTS IN DRIVE	OE PART NUMBER	COMMENT
0	REEL BY 2 - STEP GEAR	1	661220.0	
1	TRAVEL DRIVE - OM 441 A	1	661239.0	
1	TRAVEL DRIVE - OM 366 LA	1	661451.0	
2	HYDRAULIC PUMP - OM 441 A	1	633030.2	
2	HYDRAULIC PUMP - OM 366	1	767057.1	
3	AIR CONDITIONING - OM 366 LA	1	629908.1	
3	AIR CONDITIONING - OM 441 A	1	661114.0	
4	TANK UNLOADING - OM 366 LA	1	660409.0	
4	TANK UNLOADING - OM 441 A	1	661093.0	
5	THRESHING MACHINE - OM 441 A	1	644403.0	
5	THRESHING MACHINE - OM 366 LA	1	644404.1	
6	COUNTERSHAFT	1	603337.0	
7		1	644141.1	
8		1	644447.0	
11	REEL BY 4.5 M - 5.1 M	1	670224.1	X
13	FOR MULTIMASTER	1	629142.0	
13	FOR MULTIMASTER	1	692149.0	
13	FOR MULTIMASTER	1	692150.0	
16	REEL BY 6.0 M - 9.0 M	1	671013.1	
18	REEL BY 4.5 M - 5.1 M	1	713506.2	
20	FEEDER CHANNEL	1	661378.1	
21	FEEDER DRUM	1	661031.0	
22	BLOWER	1	603380.1	
23	SHAKER SHOE	1	609762.0	
24	STRAW WALKER	1	506671.2	
25	STRAW DISTRIBUTOR	1	623427.1	
27	STRAW SHOPPER	1	060306.2	
30	COOLER	1	661345.0	
31	COUNTERSHAFT - OM 366 LA	1	661244.0	
31	COUNTERSHAFT - OM 441 A	1	661245.0	
33	STRAW CHOPPER FOR MAIZE	1	061214.0	
33	STRAW CHOPPER FOR GRAIN	1	061353.0	
34	TROMMELVORGELEGE	1	609823.0	X
35	REEL BY N 650 - 1500 RPM	1	661220.0	
35	REEL BY N 510 - 1400	1	661298.0	
36	REEL BY 6.0 M - 9.0 M	1	670224.1	X
40	CHOPPER	1	695610.0	X
41	CHOPPER	1	680334.1	
42	FOR AIR EXHAUST	1	644448.0	

X - not in standard offer

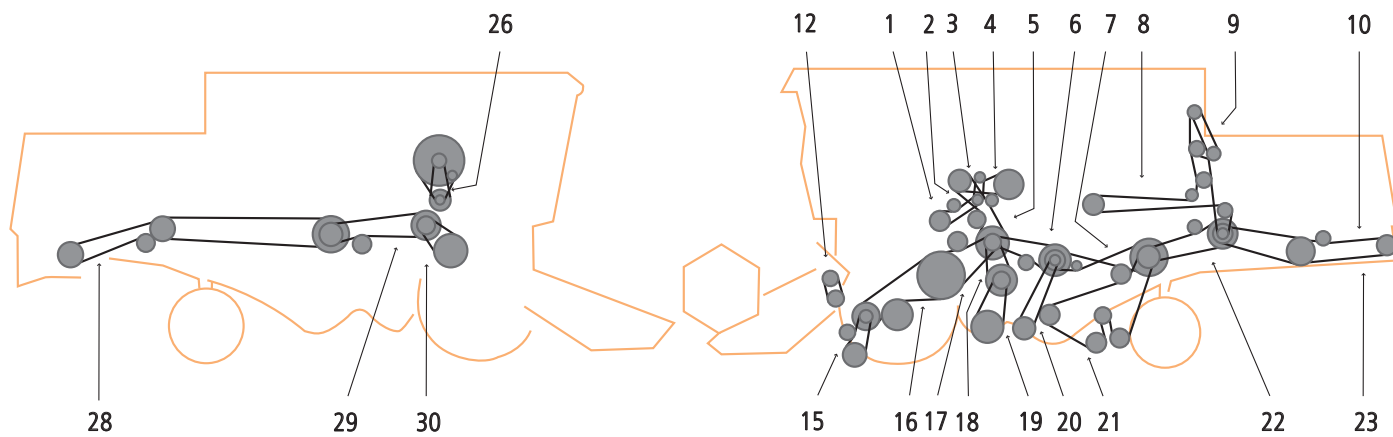

ITEM	APPLICATION	QUANTITY OF V-BELTS IN DRIVE	OE PART NUMBER	COMMENT
1	BALER	1	506880.0	
2	KNIFE DRIVE	1	756051.0	
2	COUNTERSHAFT. STRAW CHOPPER	1	801221.0	
3	TANK UNLOADER	1	756051.0	
3	TANK UNLOADER	1	756059.0	
4	RADIATOR FAN	1	758662.0	
4	RADIATOR FAN	1	758719.0	
5	CUTTING TABLE	1	772657.0	
6	GRAIN SPREADER IN TANK	1	775698.0	
7	PICK-UP	1	800309.0	
8	STRAW CHOPPER	1	506940.0	
9	SHAKER SHOE. FANNING MILL	1	775049.0	
10	HYDRAULIC PUMP	1	755070.0	
11	TRACTION DRIVE	1	750284.0	
11	TRACTION DRIVE	1	750316.0	
12	THRESHING MACHINE	1	750888.0	
13	TRACTION DRIVE	1	751112.0	
14	SHAKER SHOE. FAN.BALER	1	772658.0	
14	SHAKER SHOE. FAN.BALER	1	772659.0	X
15	STRAW WALKER. ELEVATOR	1	773313.0	
15	STRAW WALKER. ELEVATOR	1	774100.0	
16	COUNTERSHAFT. STRAW CHOPPER	1	801221.0	

X - not in standard offer

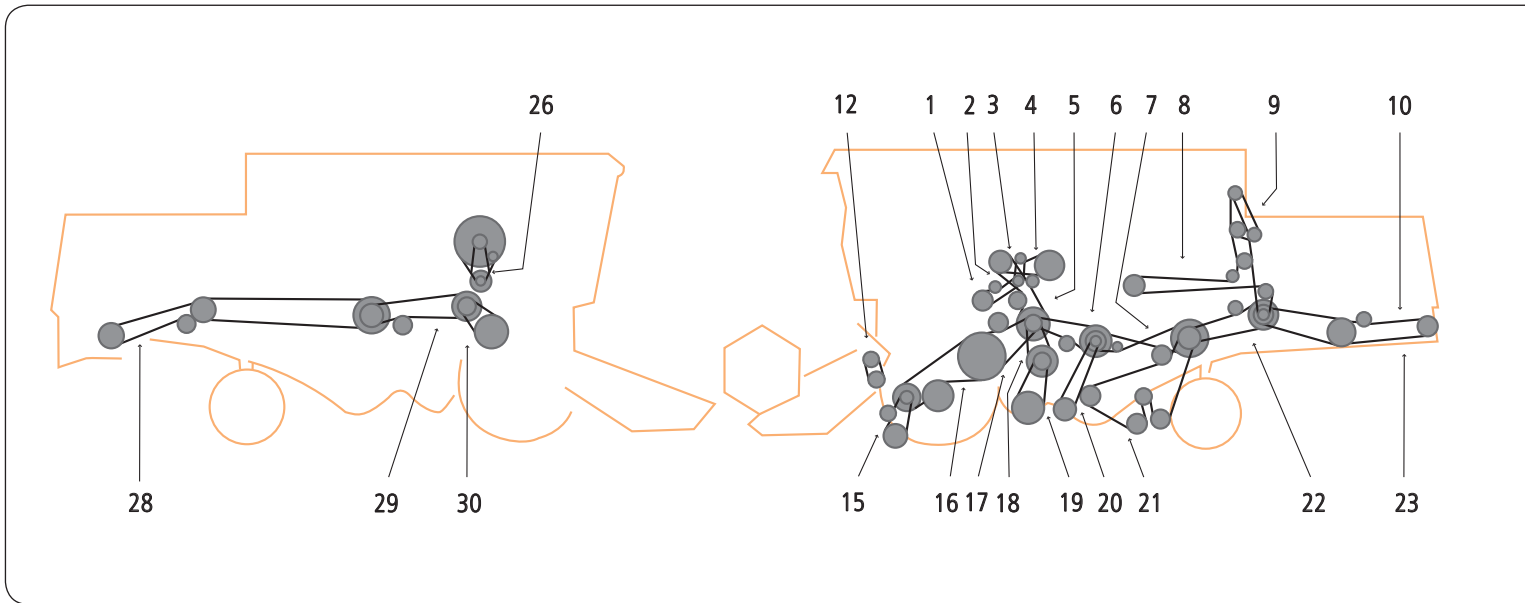

ITEM	APPLICATION	QUANTITY OF V-BELTS IN DRIVE	OE PART NUMBER	COMMENT
1	HYDRAULIC REMOTE CONTROL	1	211238.0	X
2	ANGLE GEAR BOX. RPM 540	1	943227.0	
3	ANGLE GEAR BOX. RPM 750	1	943234.0	X
4	ANGLE GEAR BOX. RPM 1000	1	211148.1	

X - not in standard offer

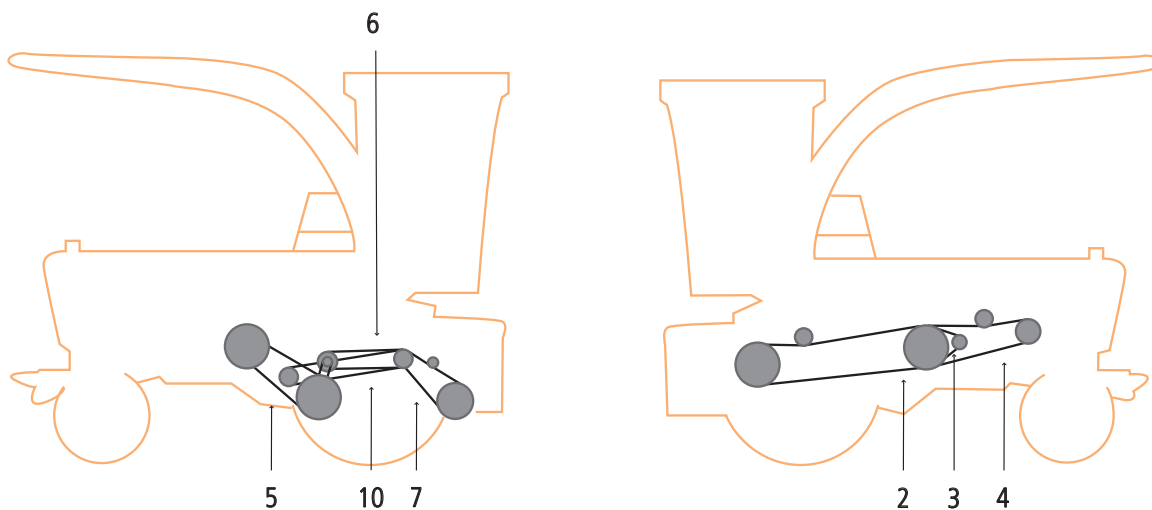

ITEM	APPLICATION	QUANTITY OF V-BELTS IN DRIVE	OE PART NUMBER	COMMENT
2	VARI SPEED DRIVE	1	063309.0	
3	HYDRAULIC PUMP DRIVE	1	633030.1	
4	ENGINE DRIVE	1	063285.0	
5	VARI SPEED DRIVE	1	629412.0	
5	VARI SPEED DRIVE	1	629737.0	
6	FEEDER DRIVE	1	618123.0	
7	FEEDER DRIVE	1	063940.0	
10	FEEDER DRIVE	1	062294.0	

X - not in standard offer

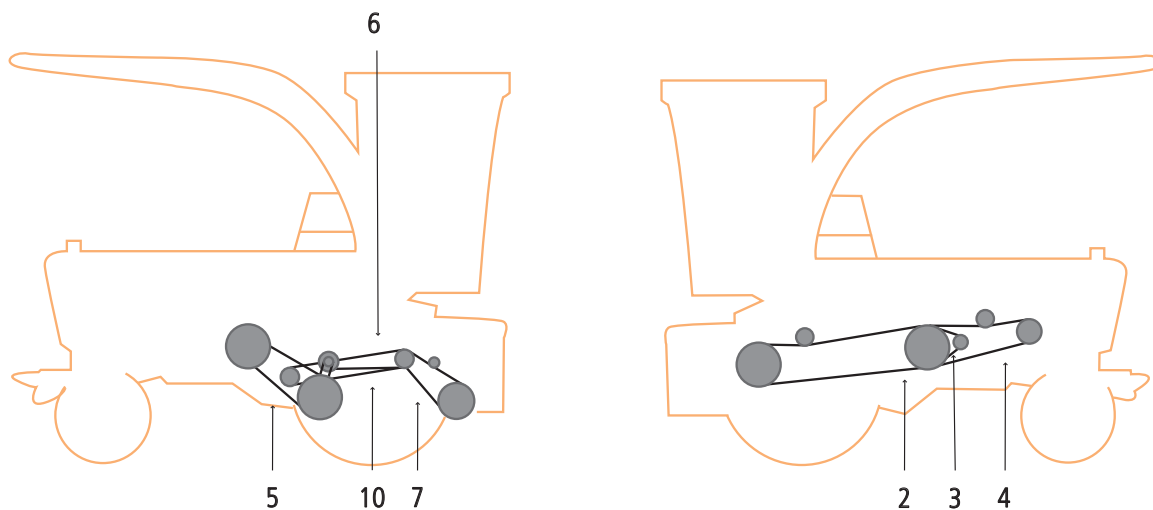

ITEM	APPLICATION	QUANTITY OF V-BELTS IN DRIVE	OE PART NUMBER	COMMENT
1	UPPER FEEDER DRIVER		981678.0	X

X - not in standard offer

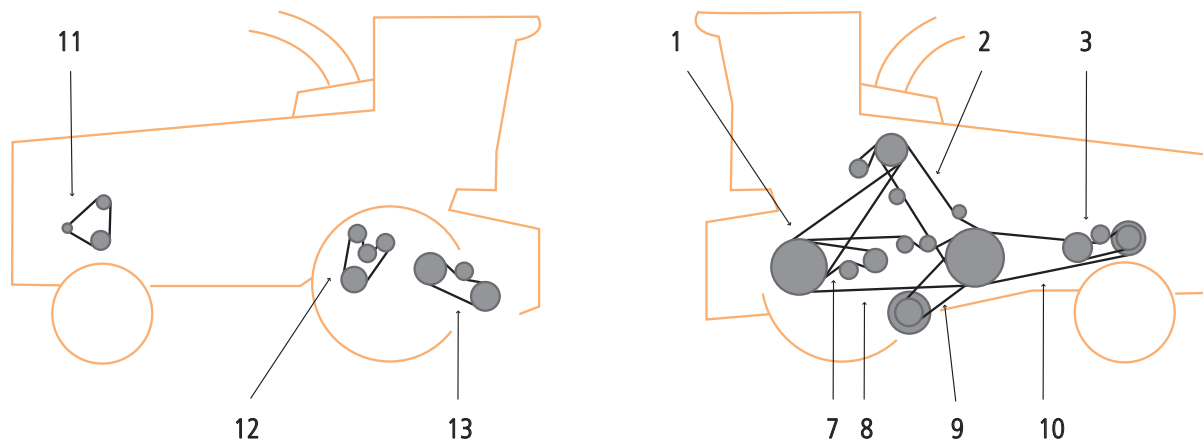

ITEM	APPLICATION	QUANTITY OF V-BELTS IN DRIVE	OE PART NUMBER	COMMENT
1	VARI-SPEED DRIVE	1	629732.2	
2	STRAW WALKER DRIVE	1	070310.1	
3	HYDRAULIC PUMP	1	750294.0	
7	CORN CRACKER	1	629763.0	
8	THRESHING DRUM	1	073202.0	
9	HYDROSTATIC SPEED DRIVE	1	073203.0	
9	MECH. SPEED DRIVE	1	629756.0	
10	ENGINE	1	073201.0	
11	GENERATOR	1	602387.0	
12	CORN CRACKER	1	073204.0	
13	FEED DRIVE	1	644015.1	
13	FEED DRIVE	1	673614.0	

X - not in standard offer

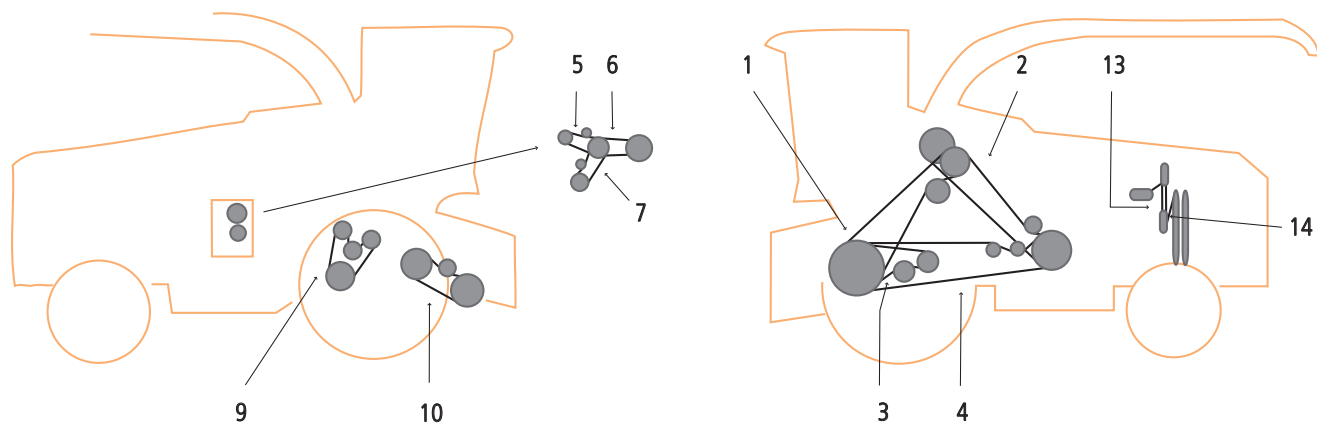

ITEM	APPLICATION	QUANTITY OF V-BELTS IN DRIVE	OE PART NUMBER	COMMENT
1	DRUM DRIVE	1	629836.0	
2	FEED DRIVE	1	070310.1	
3	LEFT CORN-CRACKER DRIVE	1	629769.0	
4	HEAD DRUM DRIVE	1	070952.2	
5	HYDRAULIC PUMP	1	750193.2	
6	AIR CONDITIONING	1	659025.0	x
7	HYDRAULIC SPEED DRIVE	1	673625.0	
7	HYDRAULIC SPEED DRIVE	1	176543.0	
9	RIGHT CORN - CRACKER DRIVE	1	072110.0	
10	CHOPPER DRIVE	1	673614.0	
13	GENERATOR	1	133528.0	
14	COOLING FAN	1	133630.0	
15	FOR COMBINE PLATFORM	1	673614.0	

X - not in standard offer

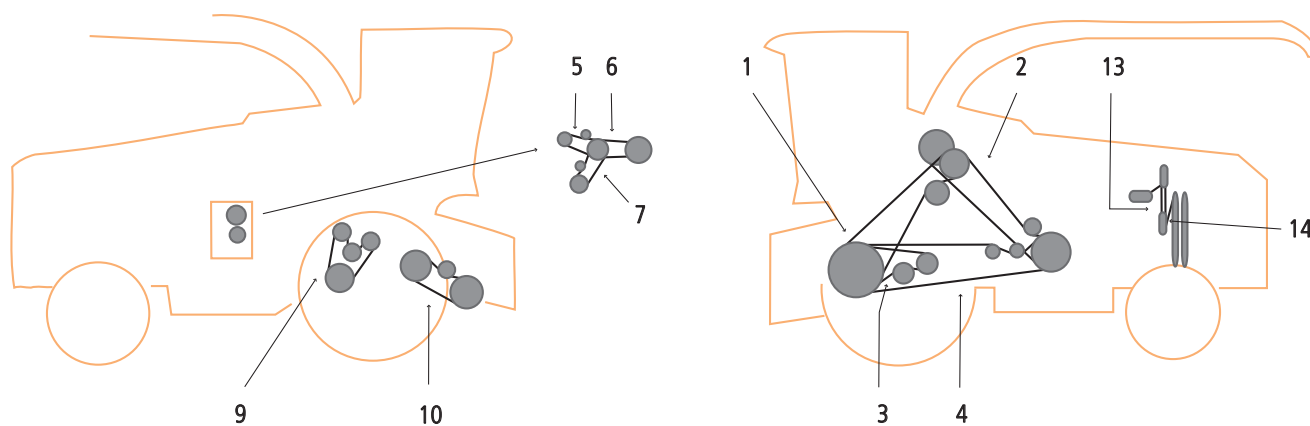

ITEM	APPLICATION	QUANTITY OF V-BELTS IN DRIVE	OE PART NUMBER	COMMENT
1	DRUM DRIVE	1	629836.0	
2	FEED DRIVE	1	070310.1	
3	GENERATOR	1	133528.0	
4	COOLING FAN	1	133630.0	
5	CORN CRACKER DRIVE	1	629763.0	
6	FOR JAGUAR 690/685 SL	1	070952.2	
6	FOR JAGUAR 695 SL	1	074771.1	
6	FOR JAGUAR 690/685 SL	1	074803.1	
7	HYDRAULIC PUMP DRIVE	1	750193.2	
8	AIR CONDITIONING	1	659025.0	X
9	VARI-SPEED DRIVE	1	176543.0	
10	CORN CRACKER	1	073204.0	
11	FEEDER DRIVE	1	673614.0	
15	FOR COMBINE PLATFORM	1	673614.0	

X - not in standard offer

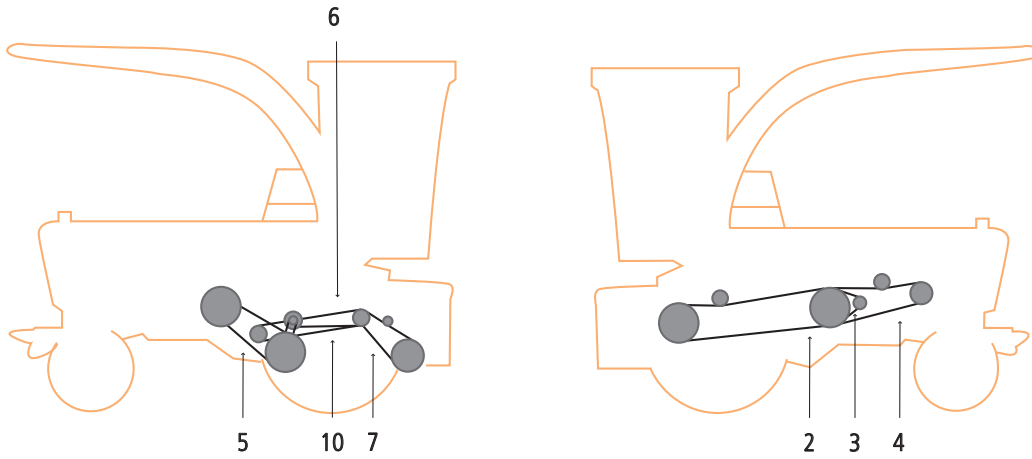

ITEM	APPLICATION	QUANTITY OF V-BELTS IN DRIVE	OE PART NUMBER	COMMENT
1	MAIN DRIVE FOR JAGUAR 840	1	077796.0	
1	MAIN DRIVE FOR JAGUAR 820	1	077797.0	
2	GENERATOR	1	512087.0	
3	COMPRESSOR	1	052393.1	
4	AIR FAN	1	077400.0	
5	CLEANING DRIVE	1	077276.0	
6	CORN CRACKER	1	076403.1	
7	BLOWER DRIVE	1	984855.0	X

X - not in standard offer

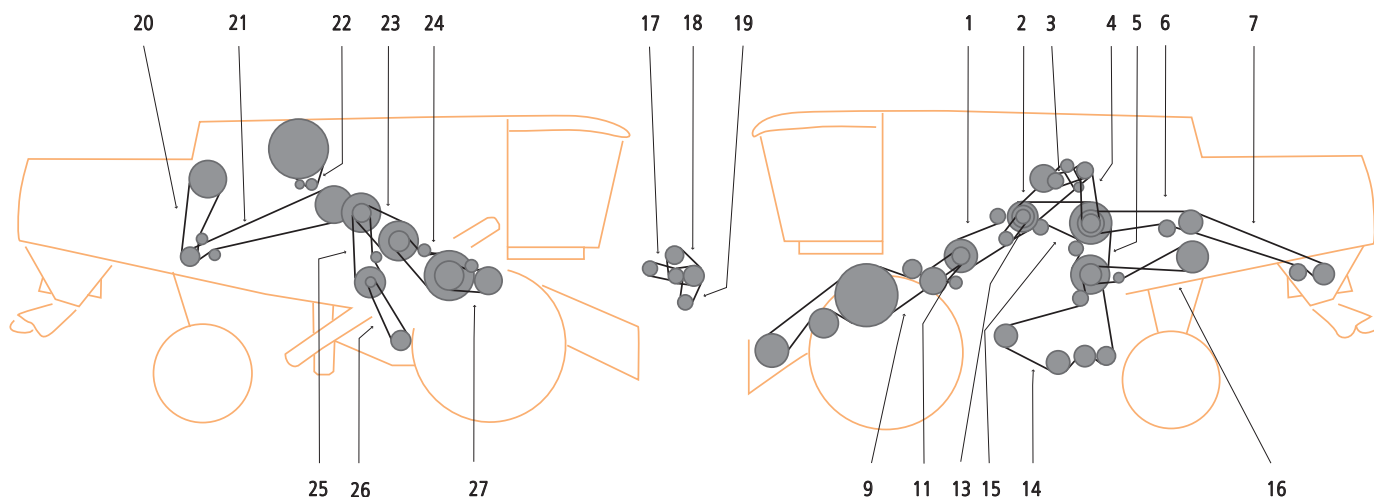

ITEM	APPLICATION	QUANTITY OF V-BELTS IN DRIVE	OE PART NUMBER	COMMENT
0	THRESHING DRUM DRIVE	1	667248.0	X
0	KNIFE DRIVE	1	742025.0	
0	REEL VARIABLE SPEED DRIVE	1	670244.1	X
1	CUTTERBAR DRIVE	1	667947.0	
2	THRESHING MACHINE	1	667680.0	
3	GRAIN TANK UNLOADING DRIVE	1	667681.0	
4	STRAW CHOPPER DRIVE. 1 STAGE	1	667981.2	
5	SIEVE PAN DRIVE. 2 STAGE	1	667252.0	
6	STRAW CHOPPER DRIVE. 2 STAGE	1	667683.0	
7	STRAW CHOPPER DRIVE. 3 STAGE	1	644771.0	
9	CUTTERBAR DRIVE	1	667454.0	
11	IMPELLER DRUM DRIVE	1	667249.0	
13	HYDRAULIC PUMP DRIVE	1	758719.0	
14	SIEVE PAN DRIVE. 3 STAGE	1	667651.0	
15	SIEVE PAN DRIVE. 1 STAGE	1	644209.0	
16	STRAW WALKER DRIVE	1	667477.0	
17	COMPRESSOR DRIVE	1	667560.1	
18	FAN AND ROTARY SCREEN DRIVE	1	667242.0	
19	ALTERNATOR. STARTER	1	667673.0	
20	REAR AGITATOR DRIVE	1	667973.0	
21	FRONT AGITATOR	1	667974.0	
22	ROTARY SCREEN DRIVE	1	667561.1	
23	THRESHING DRUM	1	661427.0	X
24	THRESHING CYLINDER	1	667934.0	
25	FAN DRIVE. 1 STAGE	1	667957.0	
26	FAN INTERMEDIATE DRIVE	1	667457.0	
27	THRESHING DRUM DRIVE	1	667251.0	

X - not in standard offer

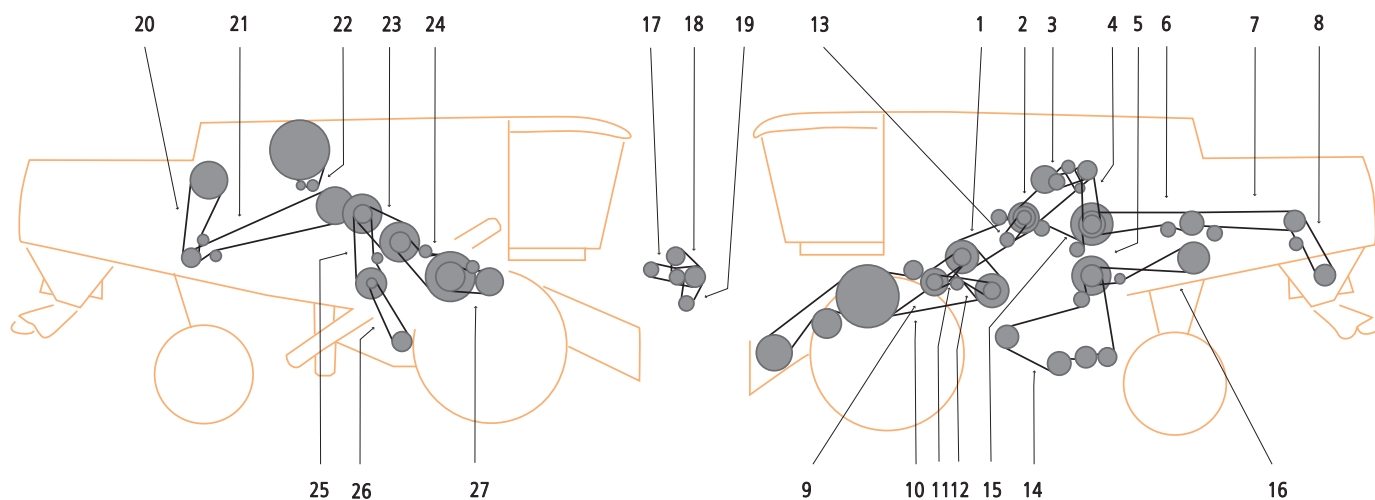

ITEM	APPLICATION	QUANTITY OF V-BELTS IN DRIVE	OE PART NUMBER	COMMENT
0	STRAW SPREADER	1	539433.0	X
0	ROTARY SCREEN DRIVE	1	667456.0	
0	KNIFE DRIVE	1	742025.0	
0	REEL VARIABLE SPEED DRIVE	1	670244.1	X
1	CLUTCH FOR CUTTERBAR DRIVE	1	667255.0	
2	THRESHING MECH. DRIVE	1	667680.0	
3	GRAIN TANK UNLOADING DRIVE	1	667681.0	
4	STRAW CHOPPER DRIVE. 1 STAGE	1	667981.2	
5	SIEVE PAN DRIVE. 2 STAGE	1	667252.0	
6	STRAW CHOPPER DRIVE. 2 STAGE	1	667633.0	X
7	STRAW CHOPPER DRIVE. 3 STAGE	1	667683.0	
8	STRAW CHOPPER DRIVE. 4 STAGE	1	667684.0	
9	CUTTERBAR DRIVE. WITHOUT VARI-DRIVE	1	667454.0	
10	CUTTERBAR DRIVE. WITHOUT VARI-DRIVE	1	667551.0	
11	IMPELLER DRUM DRIVE	1	667249.0	
12	CUTTERBAR VARIABLE SPEED DRIVE	1	667530.0	X
13	HYDRAULIC PUMP DRIVE	1	758719.0	
14	SIEVE PAN DRIVE. 3 STAGE	1	667651.0	
15	SIEVE PAN DRIVE. 1 STAGE	1	644209.0	
16	STRAW WALKER DRIVE	1	667477.0	
17	COMPRESSOR DRIVE	1	667560.1	
18	FAN AND ROTARY SCREEN DRIVE	1	667242.0	
19	ALTERNATOR. STARTER	1	667673.0	
20	REAR AGIATATOR DRIVE	1	667973.0	
21	FRONT AGIATATOR DRIVE	1	667974.0	
22	ROTARY SCREEN DRIVE	1	667561.1	
23	THRESHING DRUM VARI-DRIVE	1	667248.0	X
24	THRESHING DRUM DRIVE	1	667458.0	
25	FAN DRIVE. 1 STAGE	1	742026.0	
26	FAN DRIVE. 1 STAGE	1	667457.0	
27	SPEED REDUCING GEAR BOX	1	667251.0	

X - not in standard offer

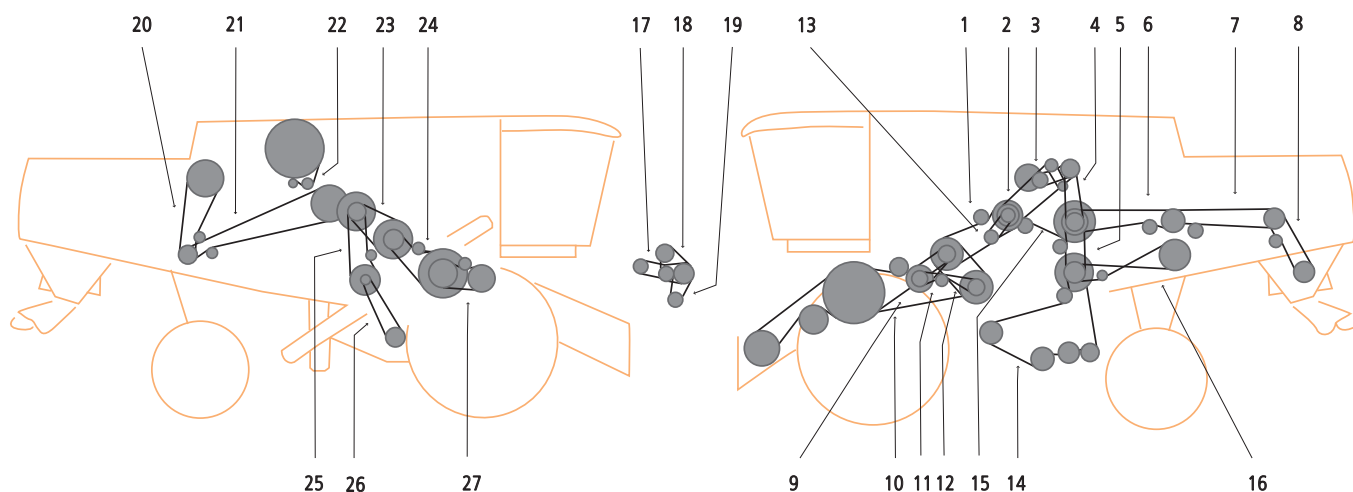

ITEM	APPLICATION	QUANTITY OF V-BELTS IN DRIVE	OE PART NUMBER	COMMENT
0	REEL VARIABLE SPEED DRIVE	1	670244.1	X
0	KNIFE DRIVE	1	742025.0	
1	CLUTCH FOR CUTTERBAR DRIVE	1	667255.0	
2	THRESHING MECHANISM DRIVE	1	667453.0	
3	GRAIN TANK UNLOADING DRIVE	1	667250.0	
4	STRAW CHOPPER DRIVE. 1 STAGE	1	667958.2	
5	SIEVE PAN DRIVE. 2 STAGE	1	667252.0	
6	STRAW CHOPPER DRIVE. 2 STAGE	1	061700.1	
7	STRAW CHOPPER DRIVE. 3 STAGE	1	061700.1	
8	STRAW CHOPPER DRIVE. 4 STAGE	1	661093.0	
9	CUTTERBAR DRIVE. WITHOUT VARI-DRIVE	1	667454.0	
10	CUTTERBAR DRIVE. WITH VARI-DRIVE	1	667551.0	
11	IMPELLER DRUM DRIVE	1	667249.0	
12	CUTTERBAR VARIABLE SPEED DRIVE	1	667530.0	X
13	HYDRAULIC PUMP DRIVE	1	758719.0	
14	SIEVE PAN DRIVE. 3 STAGE	1	667651.0	
15	SIEVE PAN DRIVE. 1 STAGE	1	644209.0	
16	STRAW WALKER DRIVE	1	667477.0	
17	COMPRESSOR DRIVE	1	667560.1	
18	FAN AND ROTARY SCREEN DRIVE	1	667242.0	
19	ROTARY SCREEN DRIVE	1	667456.0	
20	REAR AGITATOR DRIVE	1	667973.0	
21	FRONT AGITATOR DRIVE	1	667974.0	
22	ROTARY SCREEN DRIVE	1	667561.1	
23	THRESHING DRUM VARI-DRIVE	1	667248.0	X
24	THRESHING DRUM DRIVE	1	667458.0	
25	FAN DRIVE. 1 STAGE	1	742026.0	
26	FAN INTERMEDIATE DRIVE	1	667457.0	
27	SPEED REDUCING GEAR BOX	1	667251.0	

X - not in standard offer

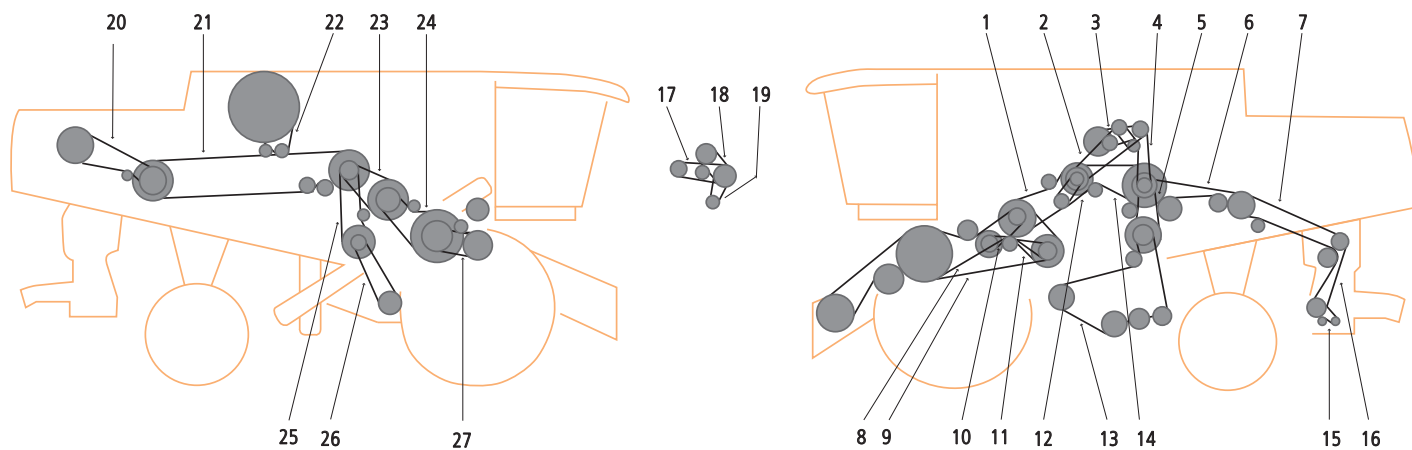

ITEM	APPLICATION	QUANTITY OF V-BELTS IN DRIVE	OE PART NUMBER	COMMENT
0	REEL VARIABLE SPEED DRIVE	1	670244.1	X
0	KNIFE DRIVE	1	742025.0	
1	CLUTCH FOR CUTTERBAR DRIVE	1	667255.0	
2	TENSIONER FOR THRESHING MECH. DRIVE	1	667881.0	
3	GRAIN TANK UNLOADING DRIVE	1	667250.0	
4	STRAW CHOPPER DRIVE. 1 STAGE	1	644685.1	
5	SIEVE PAN DRIVE. 2 STAGE	1	667252.0	
6	STRAW CHOPPER DRIVE. 2 STAGE	1	061700.1	
7	STRAW CHOPPER DRIVE. 3 STAGE	1	661298.0	
7	STRAW CHOPPER DRIVE. 3 STAGE	1	749712.0	
8	CUTTERBAR DRIVE WITHOUT VARI-DRIVE	1	667454.0	
9	CUTTERBAR DRIVE WITH VARI-DRIVE	1	667551.0	
10	IMPELLER DRUM DRIVE	1	667249.0	
11	CUTTERBAR VARIABLE SPEED DRIVE	1	667530.0	X
12	HYDRAULIC PUMP DRIVE	1	758719.0	
12	HYDRAULIC PUMP DRIVE	1	233843.1	
13	SIEVE PAN DRIVE. 3 STAGE	1	667651.0	
14	SIEVE PAN DRIVE. 1 STAGE	1	644209.0	
15	UNI SPREADER DRIVE. 2 STAGE	1	667891.0	X
16	UNI SPREADER DRIVE. 1 STAGE	1	667798.2	
17	COMPRESSOR DRIVE	1	667560.1	
18	FAN AND ROTARY SCREEN DRIVE	1	667242.0	
19	ROTARY SCREEN DRIVE	1	667456.0	
20	HYBRID DRIVE. 2 STAGE	1	667427.0	
20	HYBRID DRIVE. 2 STAGE	1	667983.0	
21	HYBRID DRIVE. 1 STAGE	1	667554.0	
22	ROTARY SCREEN DRIVE	1	667561.1	
23	THRESHING DRUM VARIABLE SPEED DRIVE	1	667248.0	X
24	THRESHING DRUM DRIVE	1	667458.0	
25	FAN DRIVE. 1 STAGE	1	742026.0	
26	FAN INTERMEDIATE	1	667457.0	
27	SPEED REDUCING GEAR BOX	1	667251.0	

X - not in standard offer

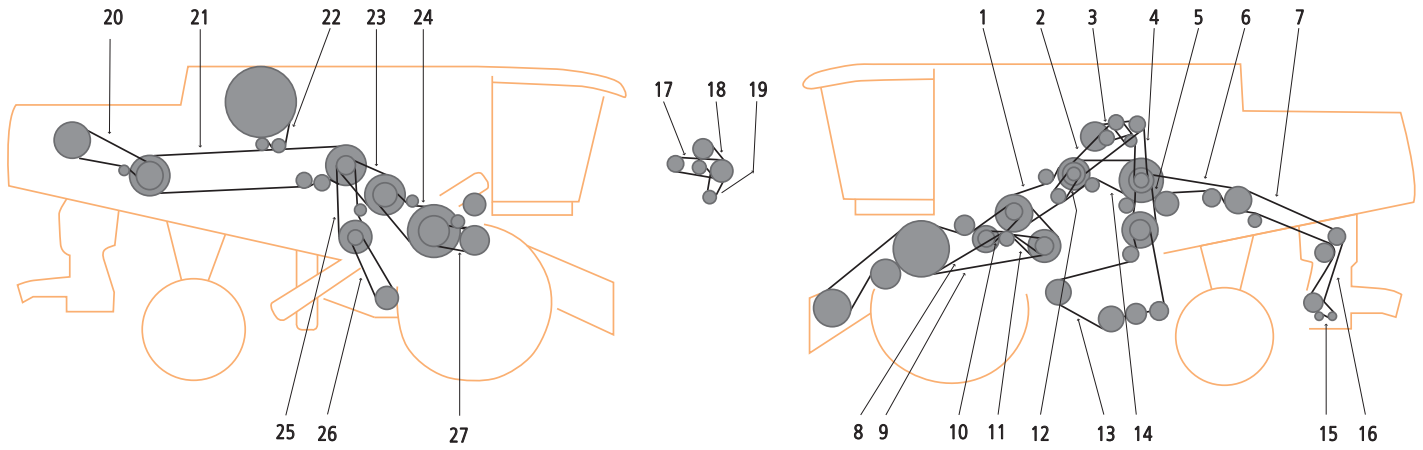

ITEM	APPLICATION	QUANTITY OF V-BELTS IN DRIVE	OE PART NUMBER	COMMENT
1	TURNING DRUM DRIVE	1	610197.0	
2	TURNING DRUM DRIVE	1	500863.0	
3	COUNTERSHAFT BALER	1	551068.0	
4	MAIN DRIVE	1	630144.0	
5	RADIATOR FAN	1	610196.0	X
5	RADIATOR FAN	1	610835.0	X
5	RADIATOR FAN	1	653121.0	
6	KNIFE DRIVE	1	610833.0	
7	CYLINDER	1	617309.0	
8	SIEVE BOX	1	523252.0	
9	FLAT BELT	1	630025.0	
9	FLAT BELT	1	630043.0	
10	HYDRAULIC PUMP	1	767057.0	
11	SIEVE BOX	1	772658.0	
12	REEL VARI	1	778561.0	X
13	PICK-UP	1	800309.0	
14	GRAIN TANK	1	636021.0	
14	GRAIN TANK	1	636021.1	
15	TRACTION DRIVE	1	630156.0	X
16	VARIABLE SPEED. DRUM	1	750294.0	
17	STRAW SHAKER	1	801222.0	

X - not in standard offer

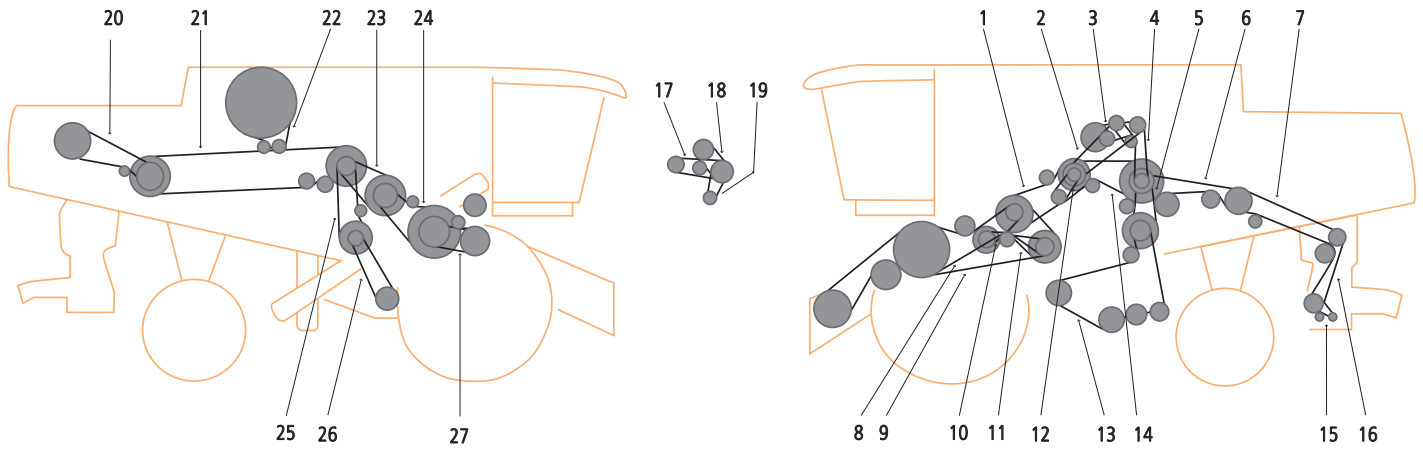

ITEM	APPLICATION	QUANTITY OF V-BELTS IN DRIVE	OE PART NUMBER	COMMENT
1		1	644016.1	
2		1	656028.0	
3		1	621903.1	
4		1	660409.0	
6		1	603337.0	
7		1	603336.1	
9		1	623427.1	
10		1	755070.1	
13		1	061214.0	
13		1	061353.1	
14		1	671209.0	X
15		1	603017.3	
19		1	506671.2	
20		1	545689.0	
21		1	056961.0	
22		1	644448.0	
23		1	609823.0	X
24		1	661220.1	
26		1	661429.0	X

X - not in standard offer

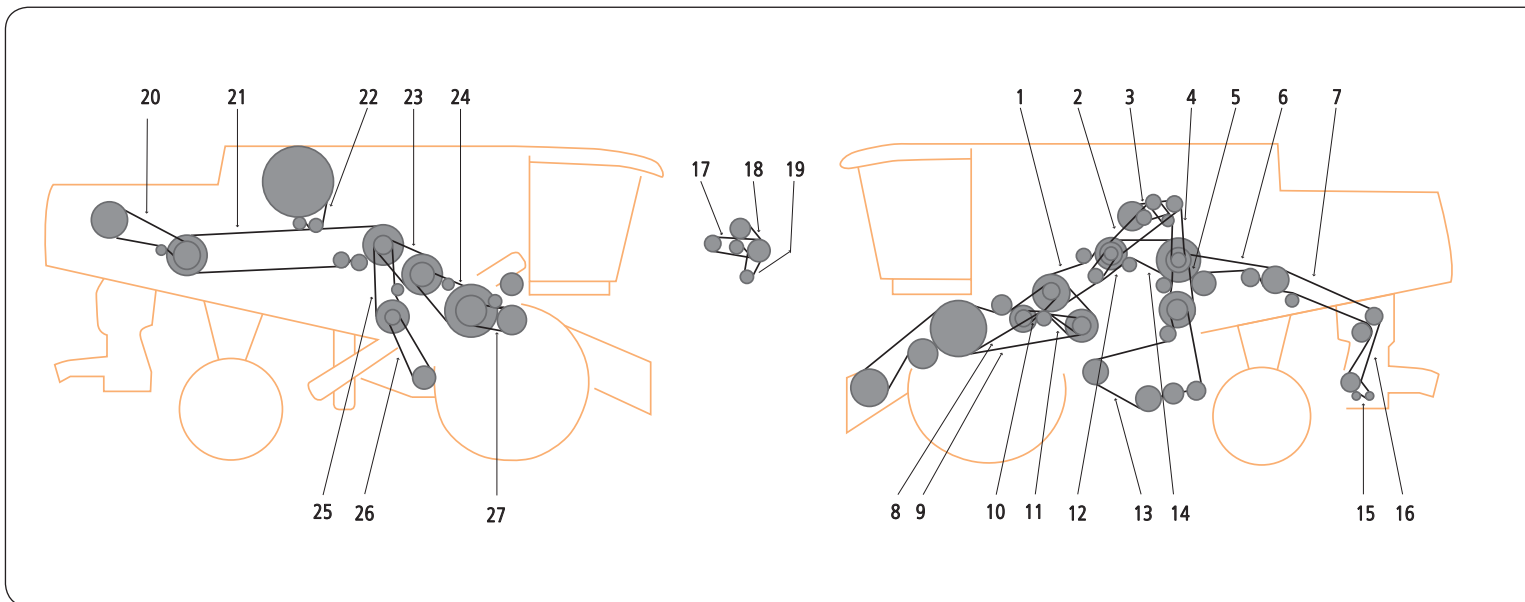

ITEM	APPLICATION	QUANTITY OF V-BELTS IN DRIVE	OE PART NUMBER	COMMENT
2		1	656028.0	
3		1	621903.1	
4		1	544166.0	
5		1	544164.0	
6		1	603337.0	
7		1	644141.1	
9		1	623427.1	
10		1	755070.1	
13		1	061214.0	
14		1	603380.1	
15		1	609762.0	
19		1	506671.2	
23		1	609823.0	X
24		1	661220.1	

X - not in standard offer

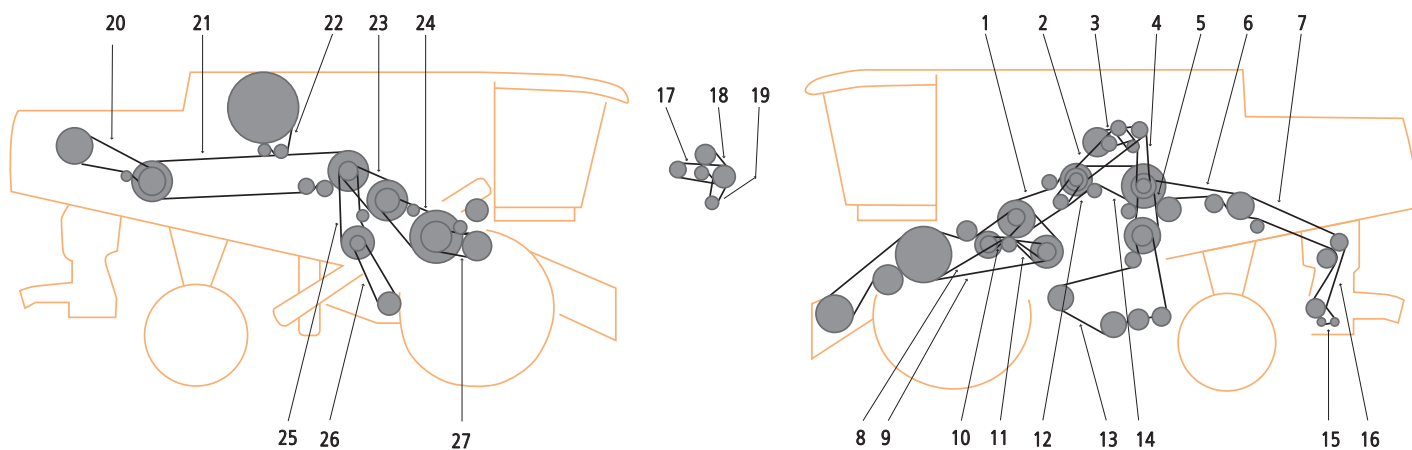

ITEM	APPLICATION	QUANTITY OF V-BELTS IN DRIVE	OE PART NUMBER	COMMENT
1	MAIN DRIVE	1	653060.0	
2	HYDRAULIC PUMP	1	656028.0	
3	MAIN DRIVE	1	630144.0	
3	MAIN DRIVE	1	653059.0	
3	MAIN DRIVE	1	653062.0	
3	MAIN DRIVE	1	653064.0	
4	VARIABLE SPEED REEL	1	778561.0	X
5	KNIFE DRIVE	1	610830.0	
5	KNIFE DRIVE	1	610833.0	
6	CUTTING TABLE	1	653063.0	
7	CYLINDER VARI-DRIVE	1	617309.0	
8	FANNING MILL	1	653121.0	
9	SHAKER SHOE DRIVE	1	653120.0	
10	GRAIN TANK	1	634019.0	
10	GRAIN TANK	1	653450.0	
11	STRAW WALKER	1	653933.0	
11	STRAW WALKER	1	755070.0	
12	TURNING DRUM DRIVE	1	750294.0	
13	TANK UNLOADER DRIVE	1	653779.0	
14	TRACTION DRIVE	1	655408.0	

X - not in standard offer

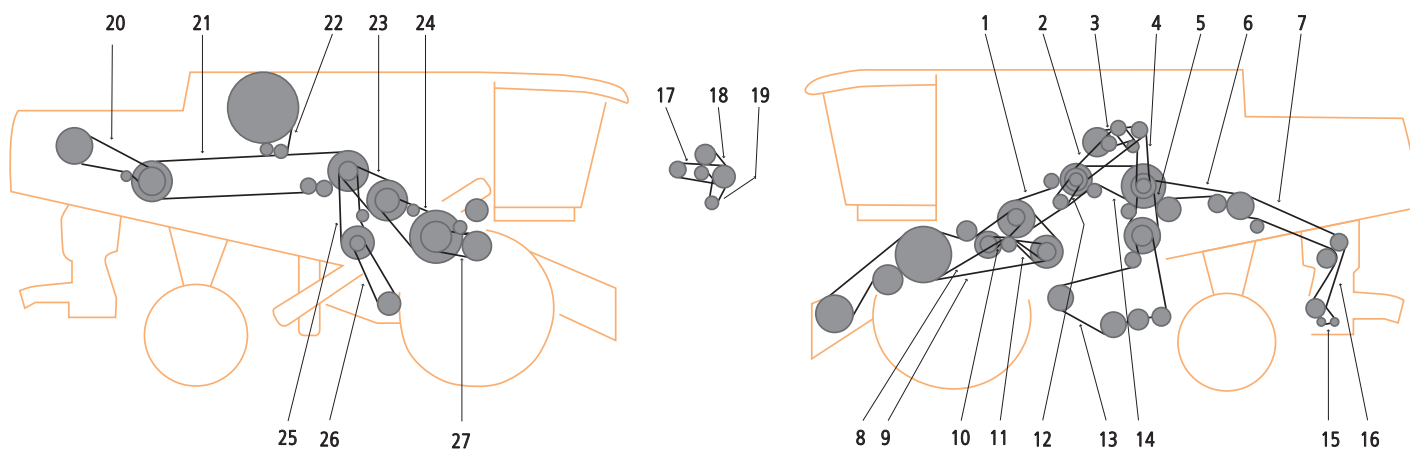

ITEM	APPLICATION	QUANTITY OF V-BELTS IN DRIVE	OE PART NUMBER	COMMENT
1	MAIN DRIVE	1	653060.0	
2	HYDRAULIC PUMP	1	656028.0	
3	MAIN DRIVE	1	630144.0	
3	MAIN DRIVE	1	653059.0	
3	MAIN DRIVE	1	653062.0	
3	MAIN DRIVE	1	653064.0	
4	VARIABLE SPEED REEL	1	778561.0	X
5	KNIFE DRIVE	1	610830.0	
5	KNIFE DRIVE	1	610833.0	
6	CUTTING TABLE	1	653063.0	
7	CYLINDER VARI-DRIVE	1	617309.0	
8	FANNING MILL	1	653380.0	
9	SHAKER SHOE DRIVE	1	653120.0	
10	GRAIN TANK	1	634019.0	
10	GRAIN TANK	1	653450.0	
11	TURNING DRUM	1	750294.0	
12	STRAW WALKER	1	653933.0	
12	STRAW WALKER	1	755070.0	
13	TANK UNLOADER DRIVE	1	654534.0	
14	TRACTION DRIVE	1	655408.0	
15	SHAKER	1	687046.0	

X - not in standard offer

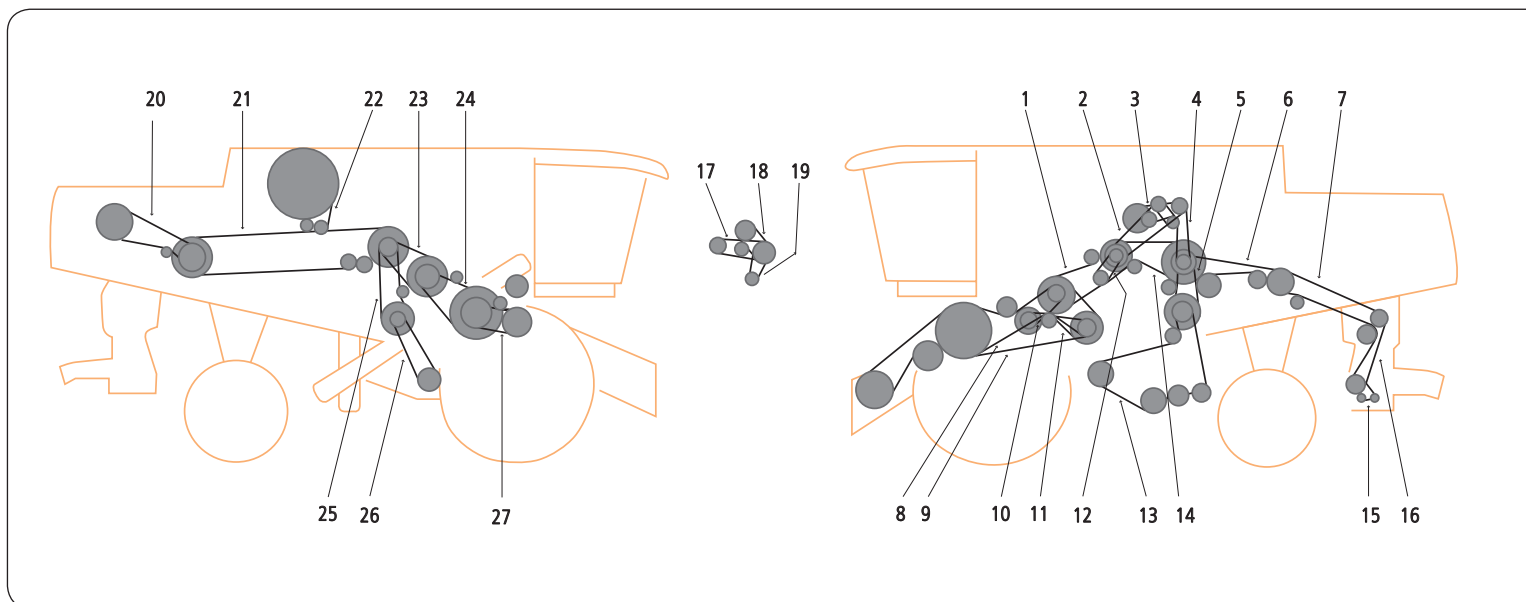

ITEM	APPLICATION	QUANTITY OF V-BELTS IN DRIVE	OE PART NUMBER	COMMENT
1	KNIFE DRIVE	1	610830.0	
1	KNIFE DRIVE	1	610833.0	
2	CYLINDER VARI-DRIVE	1	617309.0	
3	MAIN DRIVE	1	630144.0	
3	MAIN DRIVE	1	653059.0	
3	MAIN DRIVE	1	653062.0	
3	MAIN DRIVE	1	653064.0	
4	MAIN DRIVE	1	653060.0	
5	CUTTING TABLE	1	653063.0	
6	SHAKER SHOE DRIVE	1	653120.0	
7	FANNING MILL	1	653121.0	
8	STRAW SPREADER	1	653450.0	
9	HYDRAULIC PUMP	1	656028.0	
10	VARIABLE SPEED REEL	1	778561.0	X
11	STRAW WALKER	1	653933.0	
12	UNLOADING GRAIN TANK	1	654534.0	
13	TRACTION DRIVE	1	655408.0	
14	THROW OFF DRIVE	1	750294.0	

X - not in standard offer

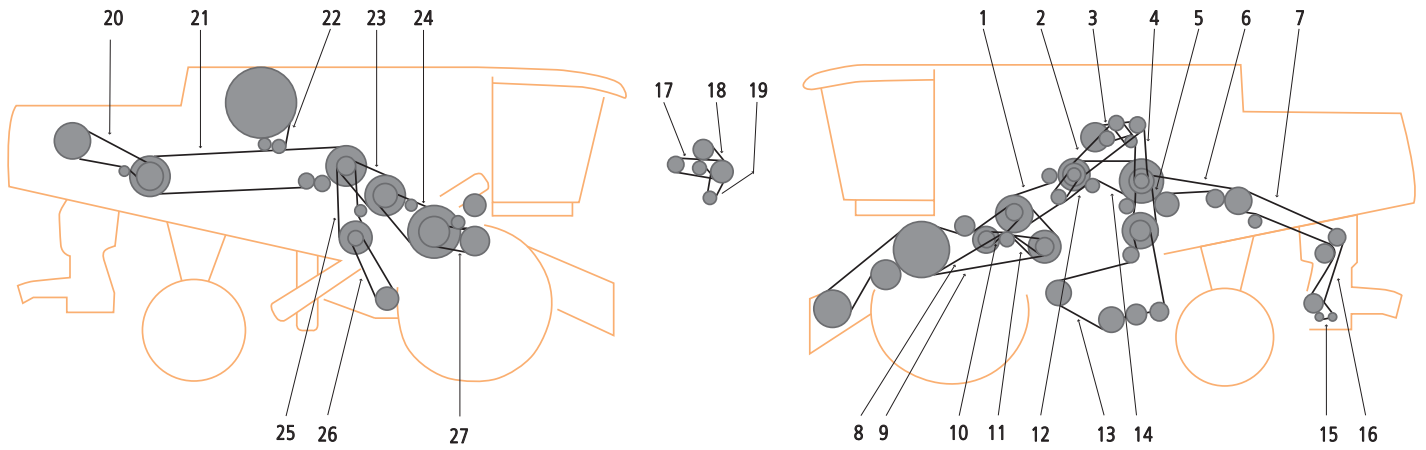

ITEM	APPLICATION	QUANTITY OF V-BELTS IN DRIVE	OE PART NUMBER	COMMENT
1	BALER	1	500863.0	
2	RADIATOR FAN	1	758662.0	
2	RADIATOR FAN	1	758719.0	
3	KNIFE DRIVE	1	770214.0	
3	KNIFE DRIVE	1	778717.0	
4	GRAIN SPREADER IN TANK	1	775698.0	
5	REEL VARI	1	778561.0	X
6	CYLINDER	1	779039.0	X
7	CUTTING TABLE	1	779214.0	
7	CUTTING TABLE	1	779272.0	
8	TANK UNLOADER	1	780419.0	
9	PICK-UP	1	800309.0	
10	STRAW CHOPPER	1	551190.0	
11	TRACTION VARI-DRIVE	1	751112.0	
13	TRACTION DRIVE	1	758853.0	
14	THRESHING MACHINE	1	758854.0	
16	SHAKER SHOE. FAN. ELEVATOR. BALER	1	779212.0	X
17	SHAKER SHOE. FAN. ELEVATOR	1	779213.0	

X - not in standard offer

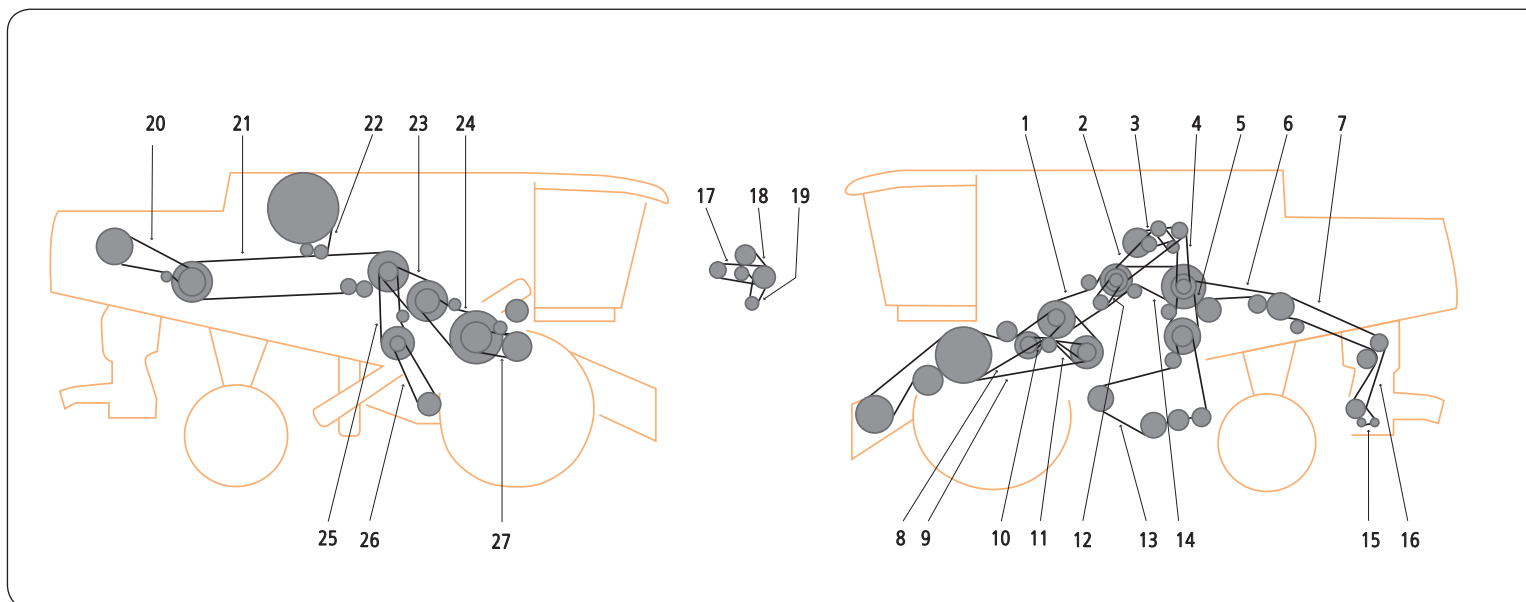

ITEM	APPLICATION	QUANTITY OF V-BELTS IN DRIVE	OE PART NUMBER	COMMENT
1	KNIFE DRIVE	1	610830.0	
1	KNIFE DRIVE	1	610833.0	
2	CYLINDER VARI-DRIVE	1	617309.0	
3	MAIN DRIVE	1	630144.0	
3	MAIN DRIVE	1	653059.0	
3	MAIN DRIVE	1	653062.0	
3	MAIN DRIVE	1	653064.0	
4	CYLINDER DRIVE	1	653060.0	
5	CUTTING TABLE	1	653063.0	
6	SHAKER SHOE DRIVE	1	653120.0	
7	FANNING MILL	1	653121.0	
8	SHAKER SHOE DRIVE	1	653450.0	
9	HYDRAULIC PUMP	1	656028.0	
10	VARIABLE SPEED. REEL	1	778561.0	X
11	TANK UNLOADER DRIVE	1	653779.0	
12	STRAW WALKER	1	653933.0	
13	TRACTION DRIVE	1	655408.0	
14	TURNING DRUM DRIVE	1	750294.0	

X - not in standard offer

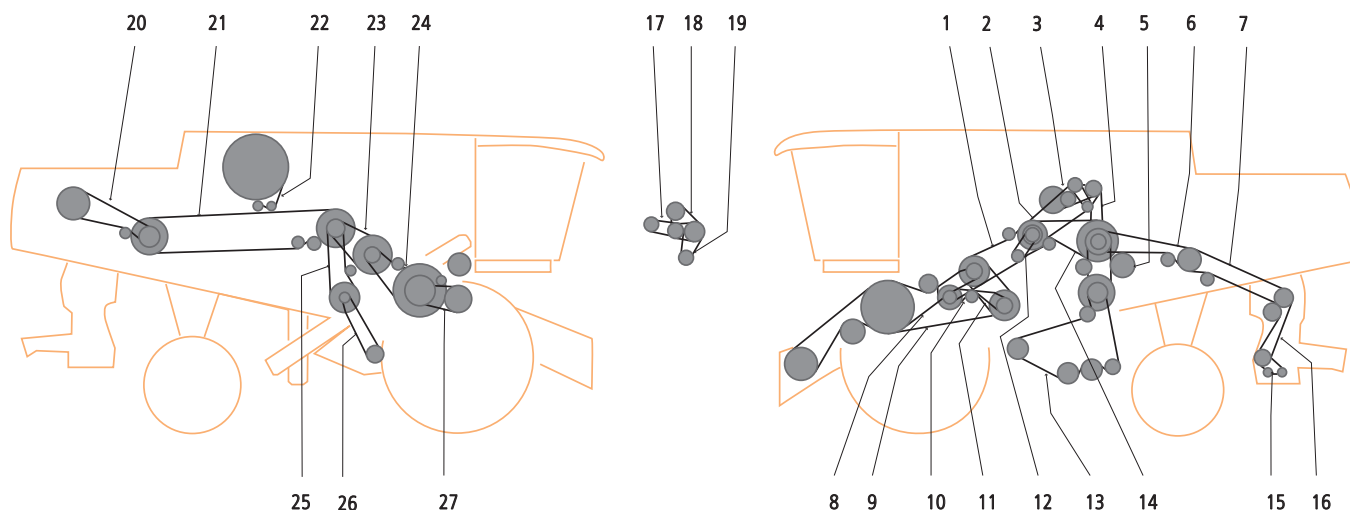

ITEM	APPLICATION	QUANTITY OF V-BELTS IN DRIVE	OE PART NUMBER	COMMENT
1	KNIFE DRIVE	1	610830.0	
1	KNIFE DRIVE	1	610833.0	
2	CYLINDER VARI-DRIVE	1	617309.0	
3	MAIN DRIVE	1	630144.0	
3	MAIN DRIVE	1	653059.0	
3	MAIN DRIVE	1	653062.0	
3	MAIN DRIVE	1	653064.0	
4	HYDRAULIC PUMP	1	633030.0	
5	CYLINDER	1	653060.0	
6	CUTTING TABLE	1	653063.0	
7	SHAKER SHOE DRIVE	1	653120.0	
8	FANNING MILL	1	653121.0	
8	FANNING MILL	1	653380.0	
9	VARIABLE SPEED REEL	1	778561.0	X
10	TRACTION DRIVE	1	631904.0	X
10	TRACTION DRIVE	1	655408.0	
11	TANK UNLOADER DRIVE	1	654013.0	
12	TURNING DRUM DRIVE	1	750294.0	
13	STRAW WALKER	1	653933.0	
13	STRAW WALKER	1	801222.0	

X - not in standard offer

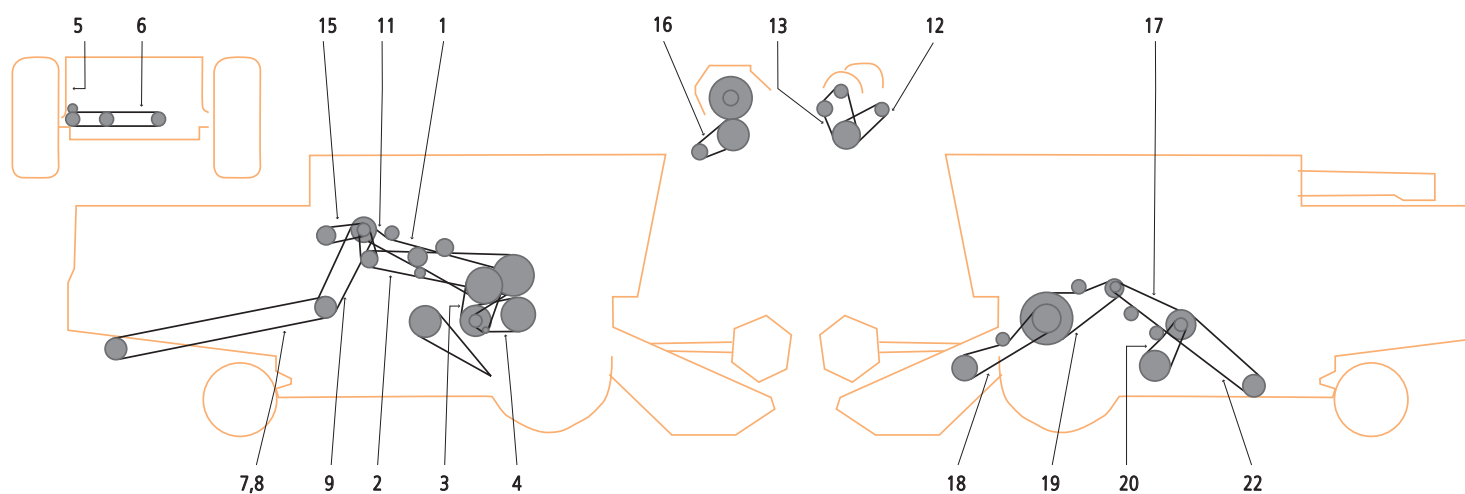

ITEM	APPLICATION	QUANTITY OF V-BELTS IN DRIVE	OE PART NUMBER	COMMENT
0			01141510	
0			01141789	
0			01141530	
0			01141941	
0			01141591	
0			01141613	X
0			01149241	X
0			06212866	
0			06257898	
1	ENGINE - STRAW STRIPPER DRUM / M3610		06215248	
2	ENGINE - GRAIN TANK EMPTYING		01141666	
3	THRESING DRUM - VARIATOR		06215222	X
4	COUNTERSHAFT - THRESING DRUM		06256546	
5	STRAW WALKERS TRANSMISSION - FAN		01139242	
6	FAN - CLEANING FAN		06210890	
8	STRAW CHOPPER - STRAW HOOD / M3610		01141645	
8	STRAW CHOPPER - STRAW HOOD / M3630/M3640		01141749	
9	ENGINE - CHOPPER TRANSMISSION		1210737011900	
11	ENGINE - GRAIN TANK CLUTCH		01141613	X
12	GENERATOR DRIVE / TYP 6204		02235180	
13	BLOWER DRIVE / +263 TYPE 6204		02235177	
13	BLOWER DRIVE / -262 TYPE 6204		02234343	
15	COMPRESSOR - TYPE COOLING PLANT		01139229	
16	GENERATOR DRIVE / TYPE 6208		02235713	
17	STRAW STRIPPER DRUM - WALKERS TRANSMISSION		06256619	
18	CUTTING TABLE DRIVE		01141595	
18	MAIZE PICKING ATTACHMENTS DRIVE		01141615	
19	STRAW STRIPPER DRUM - FEED CHANNEL		01141608	
19	STRAW STRIPPER DRUM - FEED CHANNEL MAIZEEQ		06215268	
20	WALKERS TRANSMISSION - SHAKER SHOE TRANSMISSION		06256714	
22	WALKERS TRANSMISSION - RETURNS ELEVATOR		06210917	

X - not in standard offer

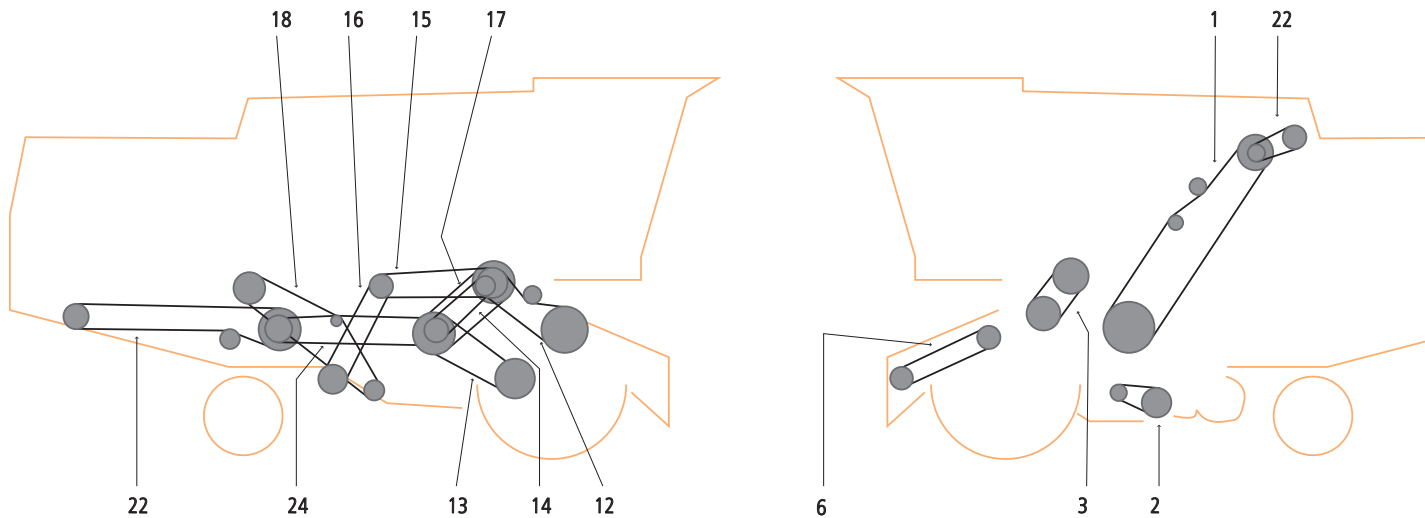

ITEM	APPLICATION	QUANTITY OF V-BELTS IN DRIVE	OE PART NUMBER	COMMENT
0	CUTTING MECH. COUNTERSHAFT - KNIFE DRIVE	1	06210991	
0	REEL VARIATOR	1	06215217	X
1	MAIN DRIVE	1	06215243	
1	MAIN DRIVE	1	06285949	
2	COUNTERSHAFT - FAN	1	06215197	X
3	STRAW STRIPPER DRUM - THRESHING DRUM	1	06215220	X
6	FEED CHANNEL - COUNTERSHAFT	1	06215205	
12	STRAW STRIPPER DRUM - FEED CHANNEL	1	06215204	X
13	COUNTERSHAFT - TRAVEL SPEED VARIATOR	1	06215216	X
14	COUNTERSHAFT - GRAIN TANK COUNTERSHAFT	1	06212924	
15	STRAW STRIPPER DRUM - TENSION ARM	1	06210991	
16	TENSION ARM - RETURNS ELEVATOR	1	06210991	
18	GRAIN ELEVATOR - STRAW WALKERS	1	06210927	
22	GENERATOR DRIVE	1	02235180	
24	CHOPPER DRIVE	1	06273236	

X - not in standard offer

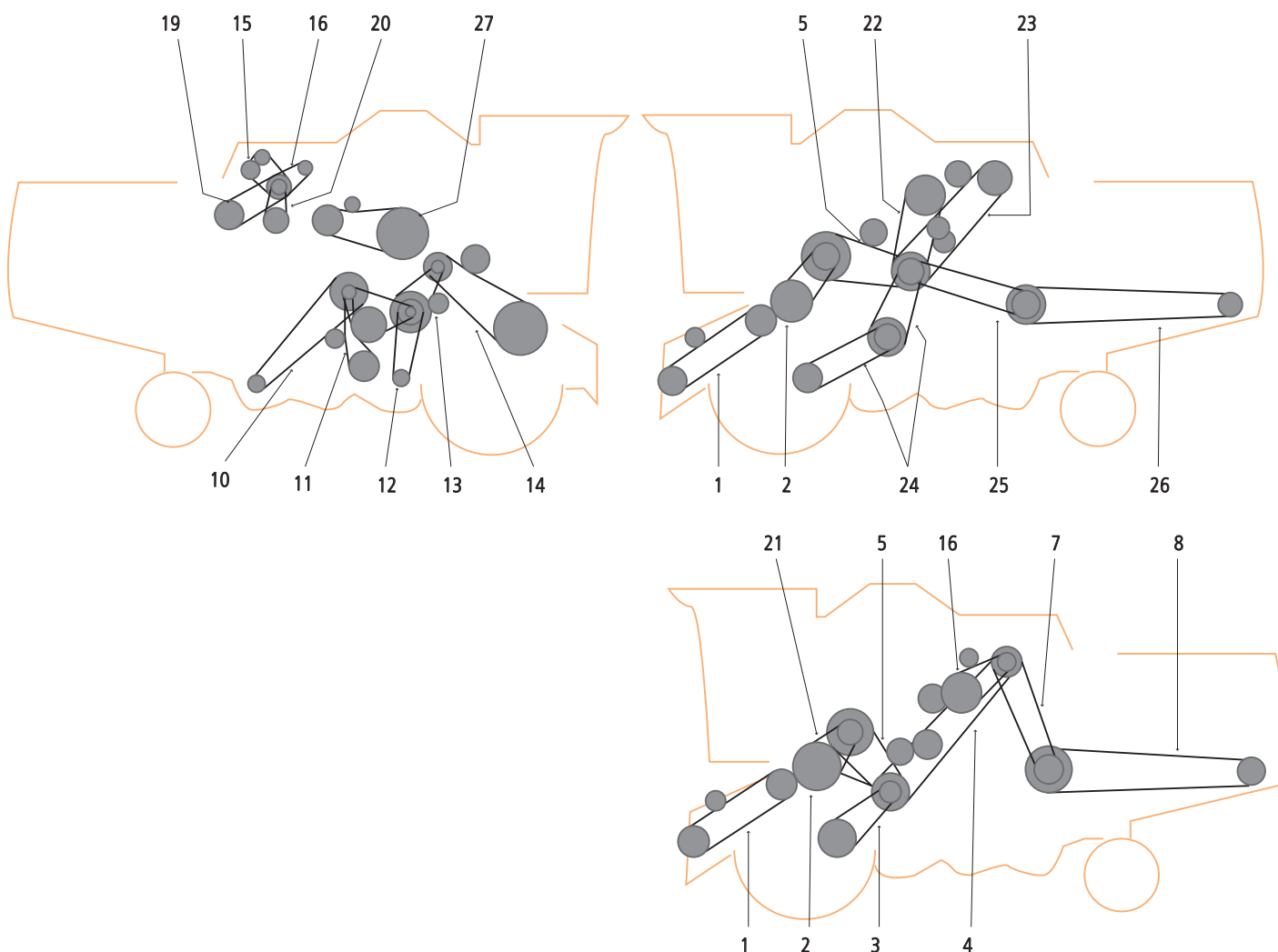

ITEM	APPLICATION	QUANTITY OF V-BELTS IN DRIVE	OE PART NUMBER	COMMENT
0	CUTTING MECH. COUNTERSHAFT - KNIFE DRIVE	1	06210991	
0	REEL VARIATOR	1	06215217	X
1	FEED CHANNEL - COUNTERSHAFT	1	06215205	
2	STRAW STRIPPER DRUM - THRESHING DRUM	1	06215220	X
3	DRIVING SPEED VARIATOR / M2580-M2685	1	06215214	X
4	ENGINE - COUNTERSHAFT / M2580.2680.2780H	1	06215258	
4	ENGINE - COUNTERSHAFT / M2685.2780	1	06215262	
5	COUNTERSHAFT - STRIPPER DRUM / M2580 - M2780H	1	06215239	
5	COUNTERSHAFT - STRAW STRIPPER DRUM	1	06215253	
7	ENGINE - CHOPPER TRANSMISSION / W /-100	1	06210851	
7	ENGINE - CHOPPER TRANSMISSION / +102	1	06215245	
8	CHOPPER TRANSMISSION / M2580.2680	1	01139258	
8	CHOPPER TRANSMISSION / M2685.2780H.2780	1	01139260	
10	COUNTERSHAFT - RETURNS ELEVATOR	1	06210922	
10	COUNTERSHAFT - RETURNS ELEVATOR / MAIZE	1	06210923	
11	COUNTERSHAFT - WALKER + SHAKER SHOE DRIVE	1	06215255	
12	COUNTERSHAFT - FAN	1	06215202	
13	STRAW STRIPPER DRUM - COUNTERSHAFT	1	06215240	
14	STRIPPER DRUM - FEED CHANNEL / M2685.2780.2780H	1	06215238	
14	STRIPPER DRUM - FEED CHANNEL / M2480-M2680	1	06215203	X
15	BLOWER DRIVE / M2685 - 2780H.2780	1	02234343	
15	BLOWER DRIVE / M2480 - M2680	1	02235532	X

ITEM	APPLICATION	QUANTITY OF V-BELTS IN DRIVE	OE PART NUMBER	COMMENT
16	GENERATOR DRIVE	1	02235180	
19	ENGINE - COMPRESSOR	1	01139233	
20	ENGINE - FAN / M2480 - M2685	1	01139204	
22	COUNTERSHAFT - GRAIN TANK / M2480	1	06210975	
23	ENGINE - COUNTERSHAFT / M2480	1	06215257	
25	COUNTERSHAFT - CHOPPER TRANSMISSION / W/M2480	1	0880077536350	
26	CHOPPER TRANSMISSION - CHOPPER / M2480	1	01139259	
27	GRAIN TANK DRIVE / + 437 M2580 - M2780H	1	06210990	
27	GRAIN TANK DRIVE / + 437 M2480	1	06210993	

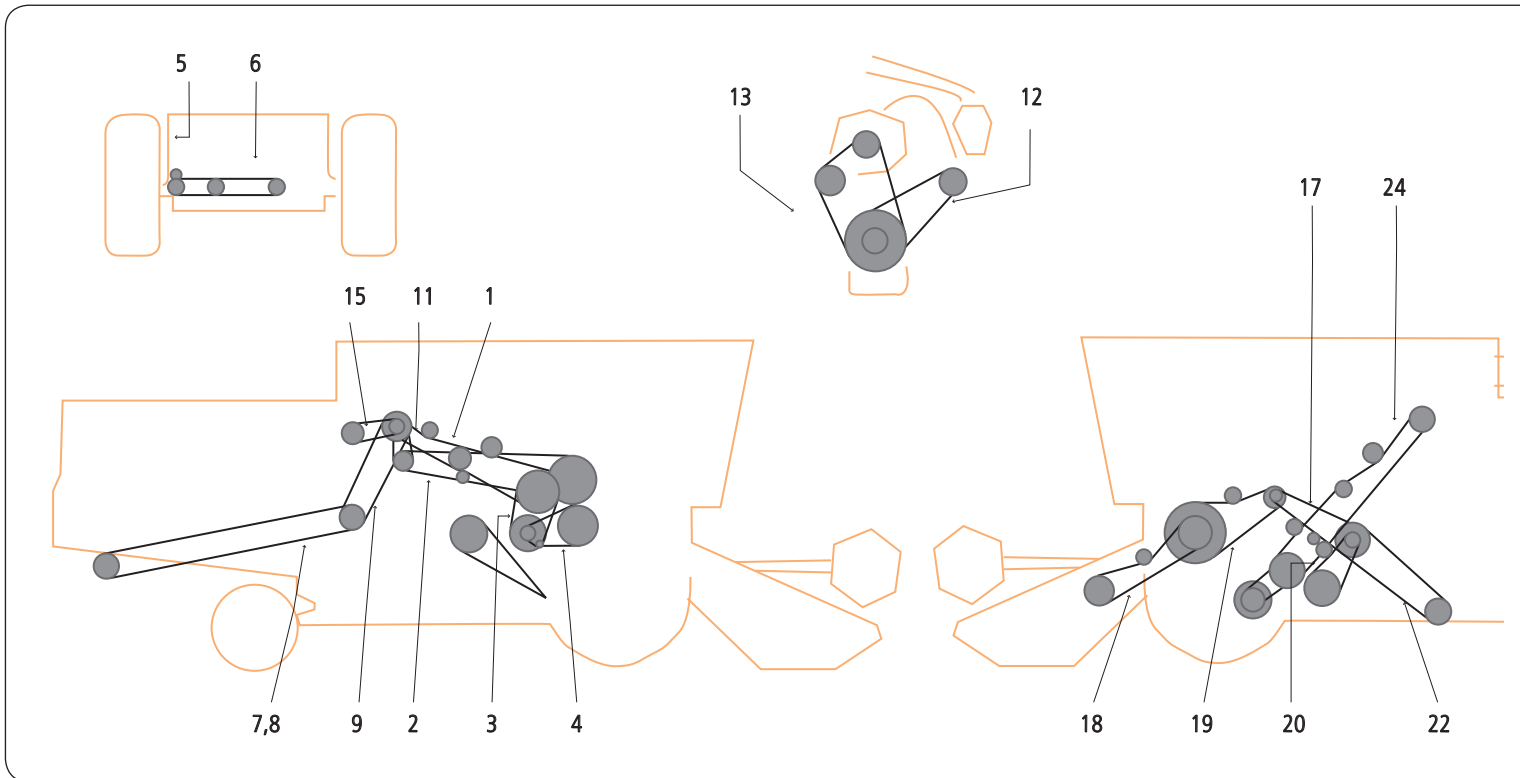

ITEM	APPLICATION	QUANTITY OF V-BELTS IN DRIVE	OE PART NUMBER	COMMENT
1		1	01141591	
2		1	01141666	
3		1	06215222	X
4		1	06256546	
5		1	01139241	
11		1	01141613	X
17		1	06256619	
18		1	01141595	
18		1	01141615	
19		1	01141608	
20		1	06256714	
23		1	01141971	X
24		1	06215244	X

X - not in standard offer

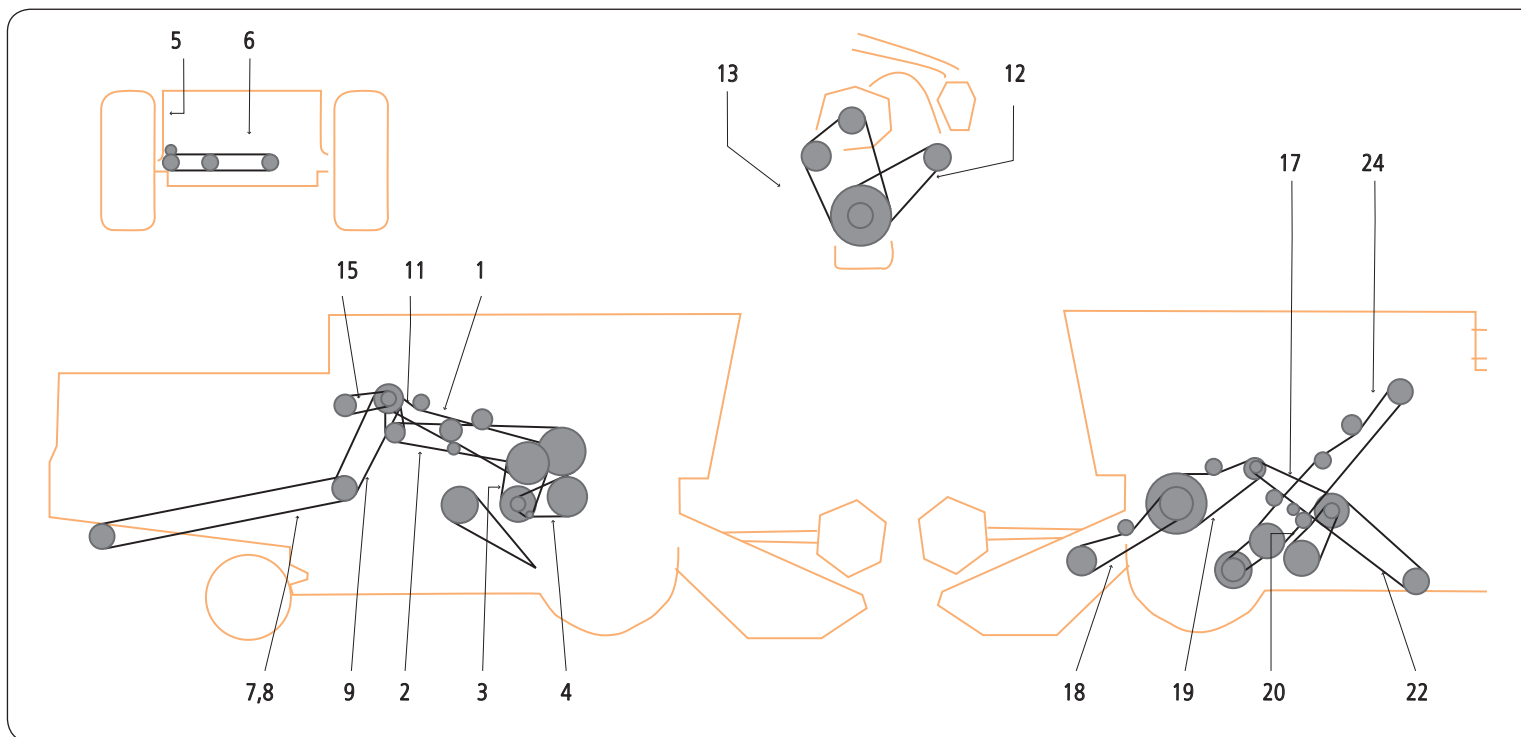

ITEM	APPLICATION	QUANTITY OF V-BELTS IN DRIVE	OE PART NUMBER	COMMENT
0		1	01141971	X
0	REEL VARIATOR	1	06215217	X
0	CUTTING MECH. COUNTERSHAFT - KNIFE DRIVE	1	06210991	
0		1	06257898	
1	STRAW STRIPPER DRUM	1	01141591	
2	GRAIN TANK EMPTYING	1	01141666	
3	THRESHING DRUM - VARIATOR	1	06215222	X
4	COUNTERSHAFT - THRESHING DRUM	1	06256546	
5	STRAW WALKERS TRANSMISSION - FAN	1	01139241	
6	FAN - CLEANING FAN	1	06210890	
8	STRAW CHOPPER - STRAW HOOD	1	01141645	
9	ENGINE - CHOPPER TRANSMISSION	1	1210737011900	
11	ENGINE - GRAIN TANK CLUTCH / M3570	1	06211014	
11	ENGINE - GRAIN TANK CLUTCH / M3580	1	01141613	X
12	GENERATOR DRIVE	1	02235180	
13	BLOWER DRIVE	1	02234343	
15	COMPRESSOR - TYPE COOLING PLANT	1	06212866	
17	STRAW STRIPPER DRUM - WALKERS TRANSMISSION	1	06256619	
18	CUTTING TABLE DRIVE	1	01141595	
18	MAIZE PICKING - ATTACHMENTS DRIVE	1	01141615	
19	STRAW STRIPPER DRUM - FEED CHANNEL	1	01141608	
20	WALKERS TRANSMISSION - SHAKER SHOE TRANSMISSION	1	06256714	
22	WALKERS TRANSMISSION - RETURN ELEVATOR	1	06210917	
23	TRAVEL SPEED VARIATOR	1	06215223	X
24	ENGINE - COUNTERSHAFT	1	06215244	X

X - not in standard offer

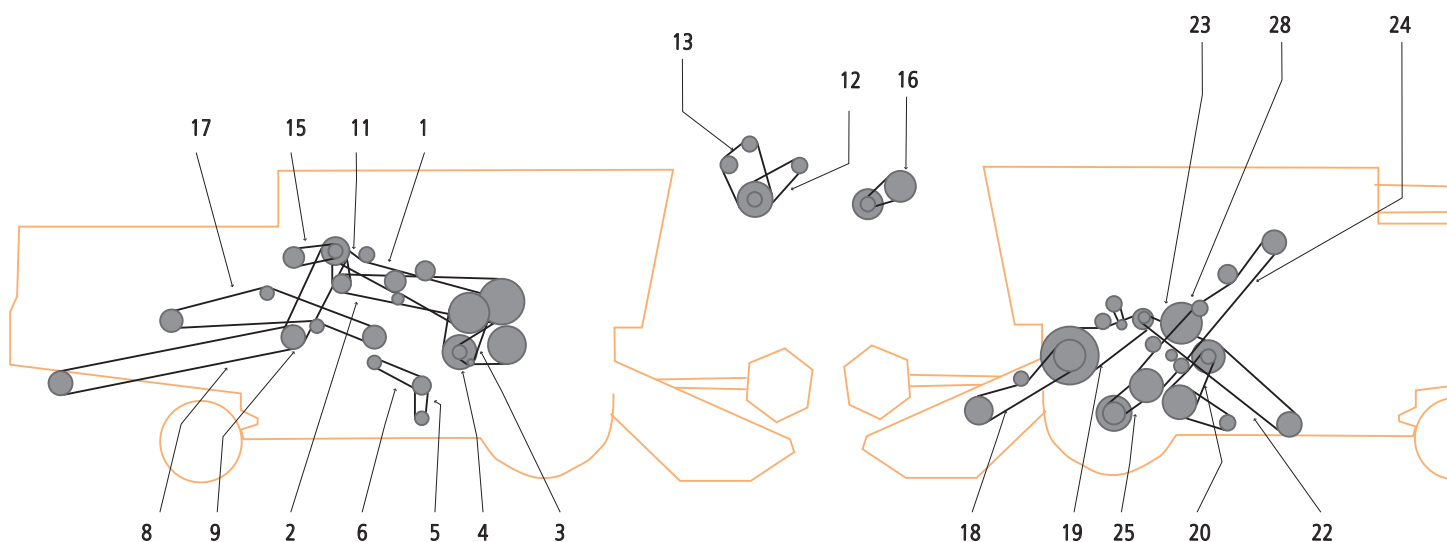

ITEM	APPLICATION	QUANTITY OF V-BELTS IN DRIVE	OE PART NUMBER	COMMENT
1	ENGINE - STRAW STRIPPER DRUM	1	01145050	
2	ENGINE - GRAIN TANK EMPTYING	1	01145055	
3	THRESHING DRUM - VARIATOR	1	01145026	X
4	COUNTERSHAFT - THRESHING DRUM	1	01145049	
5	FAN SPEED VARIATOR - CLEANING FAN	1	01145097	X
6	STRAW WALKERS TRANSMISSION - VARIATOR	1	01145202	X
8	FOR STRAW CHOPPER INTEGRATED	1	01145187	
8	FOR STRAW CHOPPER INTEGRATED	1	01145188	
9	ENGINE - CHOPPER TRANSMISSION	1	06257898	
11	ENGINE - GRAIN TANK CLUTCH	1	01141613	X
12	GENERATOR DRIVE	1	02235180	
13	BLOWER DRIVE	1	02235177	
13	BLOWER DRIVE	1	02234343	
15	COMPRESSOR - TYPE COOLING PLANT	1	06212866	
17	STRAW WALKER DRIVE	1	01145053	
17	STRAW WALKER DRIVE	1	01145054	
18	MAIZE PICKING ATTACHMENTS DRIVE	1	01145025	
18	CUTTING TABLE DRIVE	1	01143412	
18	CUTTING TABLE DRIVE	1	01145211	
19	STRAW STRIPPER DRUM - FEED CHANNEL	1	01141608	
19	MAIZE EQUIPMENT	1	01141941	
20	WALKER TRANSMISSION - SHAKER SHOE TRANSMISS.	1	01143413	
21	STRAW STRIPPER DRUM - WALKER TRANSMISSION	1	01145051	
22	WALKERS TRANSMISSION - RETURNS ELEVATOR	1	01145052	
23	STRAW SHIPPER DRUM - TURBO - SEPARATOR	1	01143410	
24	ENGINE - COUNTERSHAFT	1	01145102	X
25	TRAVEL SPEED VARIATOR	1	01141944	X

X - not in standard offer

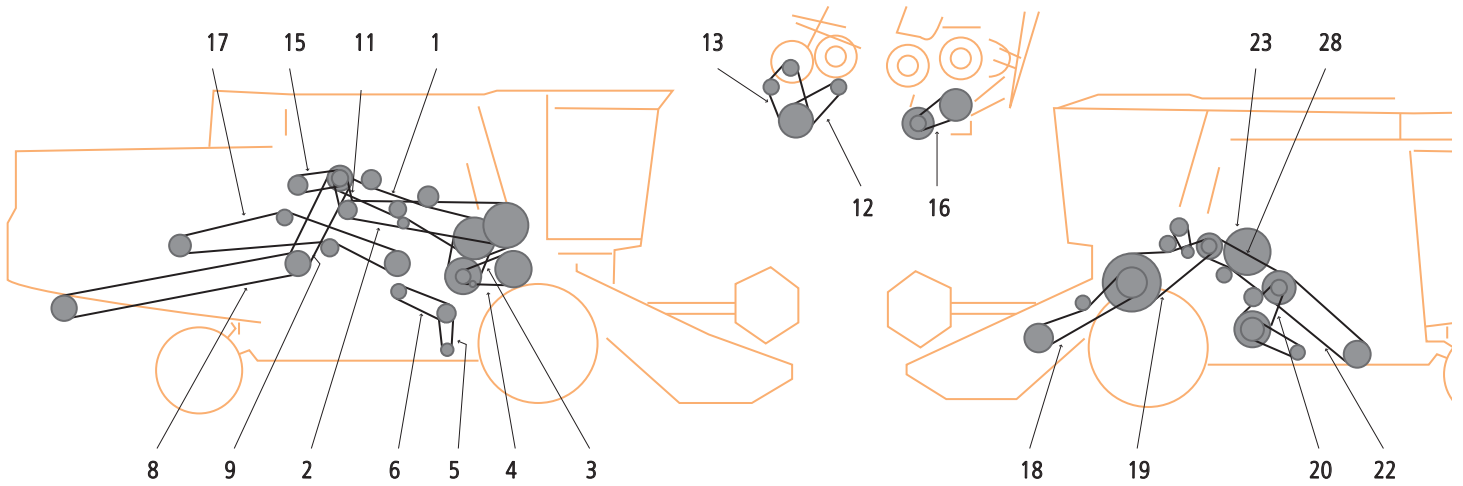

ITEM	APPLICATION	QUANTITY OF V-BELTS IN DRIVE	OE PART NUMBER	COMMENT
1	STRAW STRIPPER DRUM	1	01145056	
1	STRAW STRIPPER DRUM	1	01145057	
2	ENGINE - GRAIN TANK EMPTYING	1	01145055	
3	THRESHING DRUM VARIATOR	1	01145374	X
4	COUNTERSHAFT THRESHING DRUM	1	01145049	
5	FAN SPEED VARIATOR. CLEANING FAN	1	01145332	X
5	FAN SPEED VARIATOR. CLEANING FAN	1	01145369	X
6	STRAW WALKERS TRANSMISSION VARIATOR	1	01145331	X
8	CHOPPER DRIVE	1	01145187	
8	CHOPPER DRIVE	1	01145188	
9	CHOPPER TRANSMISSION (SET)	1	01145475	
9	CHOPPER TRANSMISSION	1	01145479	
11	GRAIN TANK CLUTCH	1	01141613	X
12	GENERATOR DRIVE FOR 4070/4075	1	02235180	
13	BLOWER DRIVE FOR 4070/4075	1	02235177	
15	COOLING PLANT	1	01145318	X
15	COOLING PLANT	1	06212866	
16	GENERATOR DRIVE FOR 4075/4080/4090	1	02237477	
17	STRAW WALKER DRIVE	1	01145053	
17	STRAW WALKER DRIVE	1	01145054	
18	CUTTING TABLE DRIVE	1	01145025	
19	FEED CHANNEL	1	01141941	
19	FEED CHANNEL	1	01145329	
20	SHAKER SHOE TRANSMISSION	1	01143413	
22	RETURNS ELEVATOR	1	01145052	
23	STRAW STRIPPER DRUM	1	01143410	
24	STRAW STRIPPER DRUM	1	01145051	

X - not in standard offer

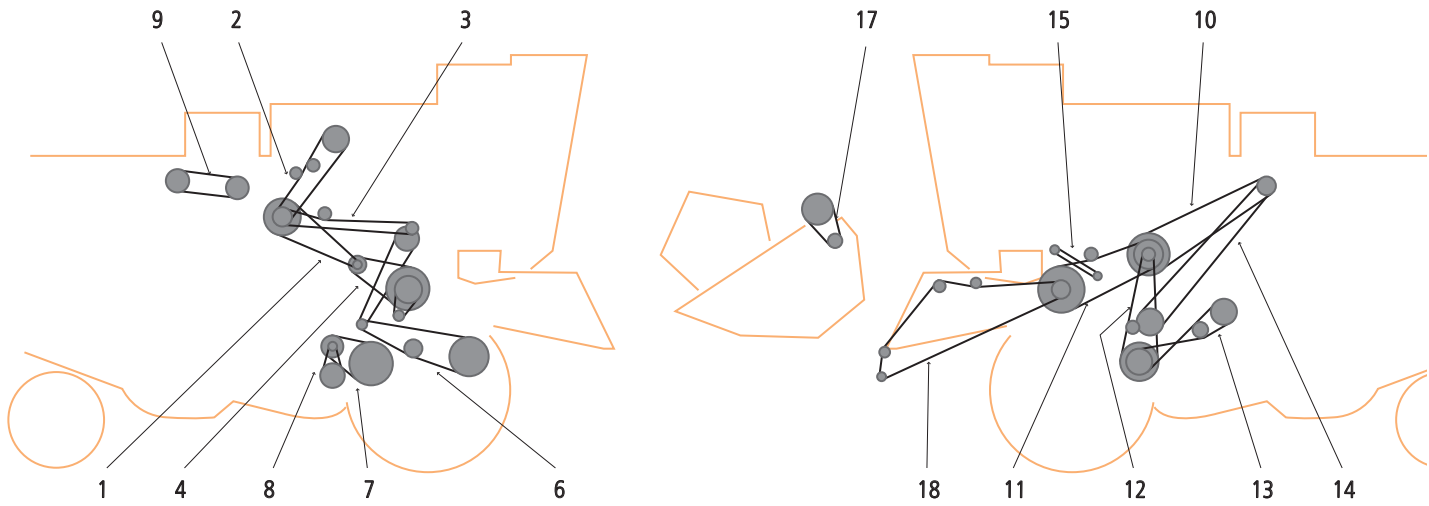

ITEM	APPLICATION	QUANTITY OF V-BELTS IN DRIVE	OE PART NUMBER	COMMENT
6		1	4250121772	
10		1	4250121764	
16		1	4250121780	

X - not in standard offer

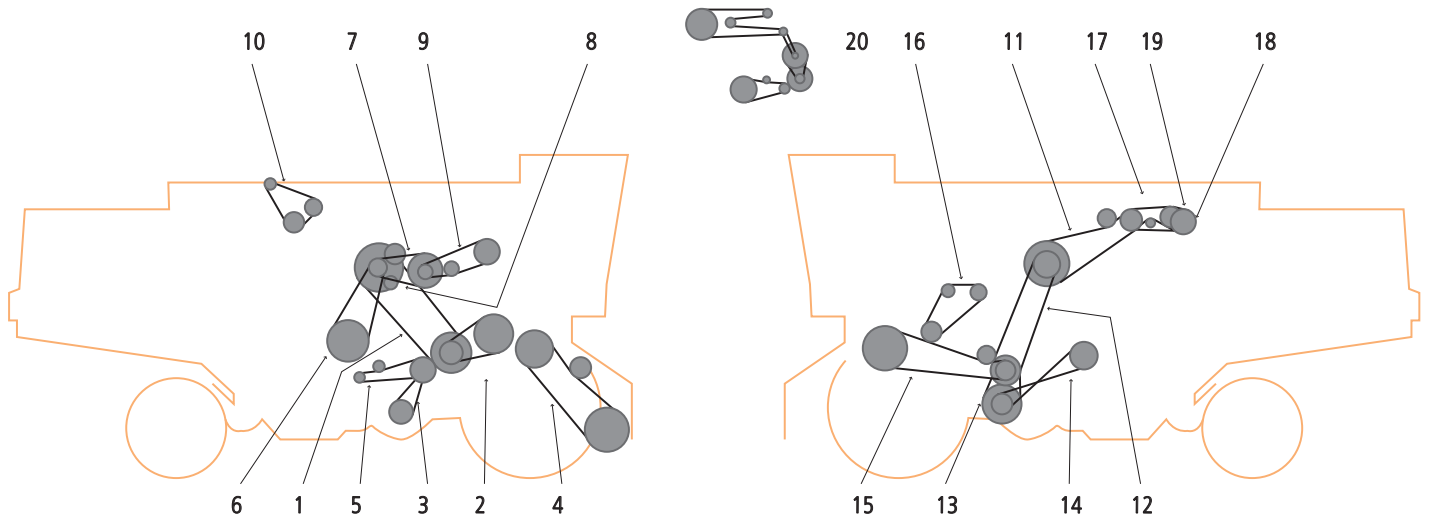

ITEM	APPLICATION	QUANTITY OF V-BELTS IN DRIVE	OE PART NUMBER	COMMENT
2		1	4240023387	
4		1	4240023395	
11		1	4240023370	
15		1	4240023395	

X - not in standard offer

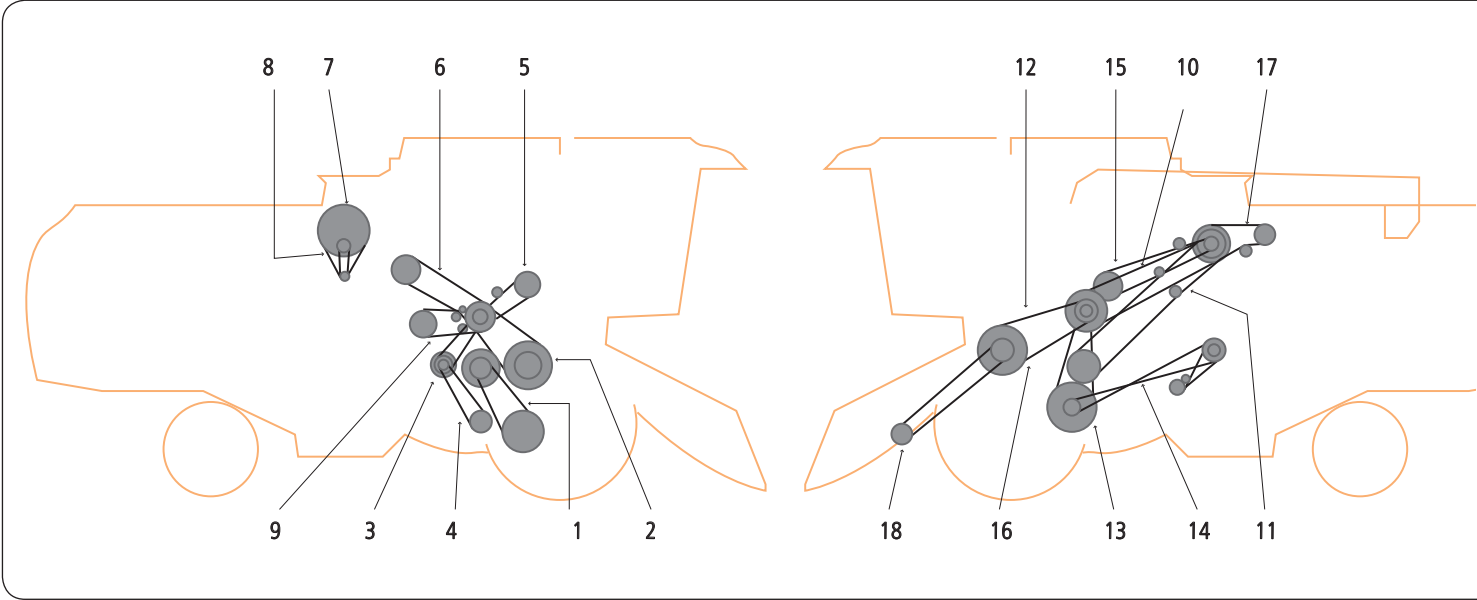

ITEM	APPLICATION	QUANTITY OF V-BELTS IN DRIVE	OE PART NUMBER	COMMENT
10		1	4260699985	
11		1	4260699960	
15		1	4260699977	
16		1	4260703942	
18		1	4260715183	

X - not in standard offer

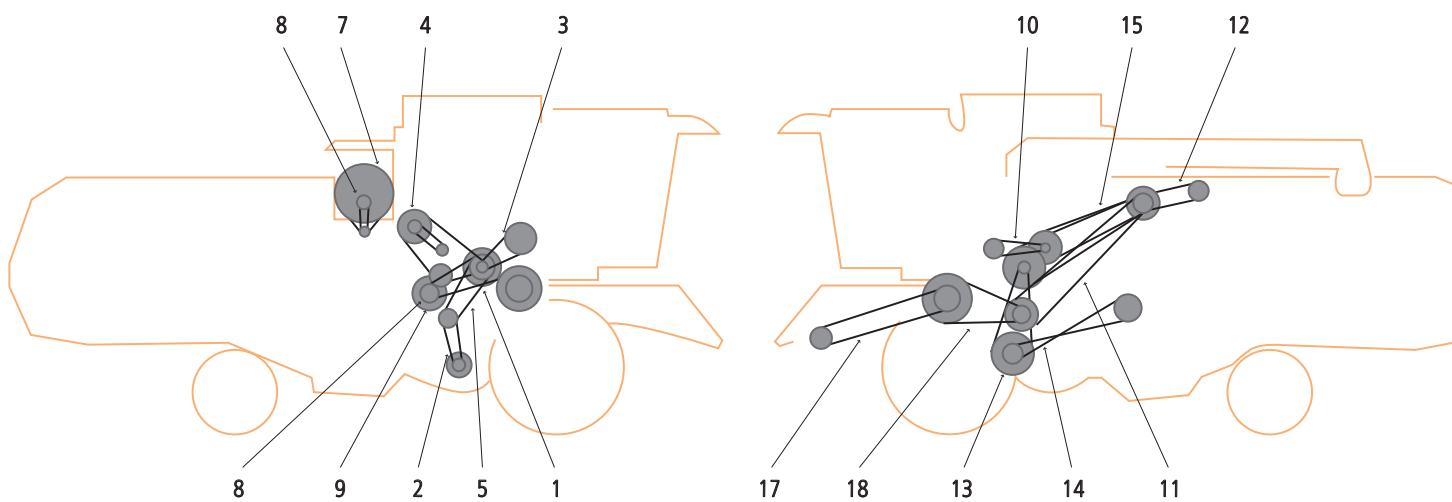

ITEM	APPLICATION	QUANTITY OF V-BELTS IN DRIVE	OE PART NUMBER	COMMENT
10		1	61020978	
11		1	60168160	
15		1	61020986	
16		1	61009074	
17		1	61004680	

X - not in standard offer

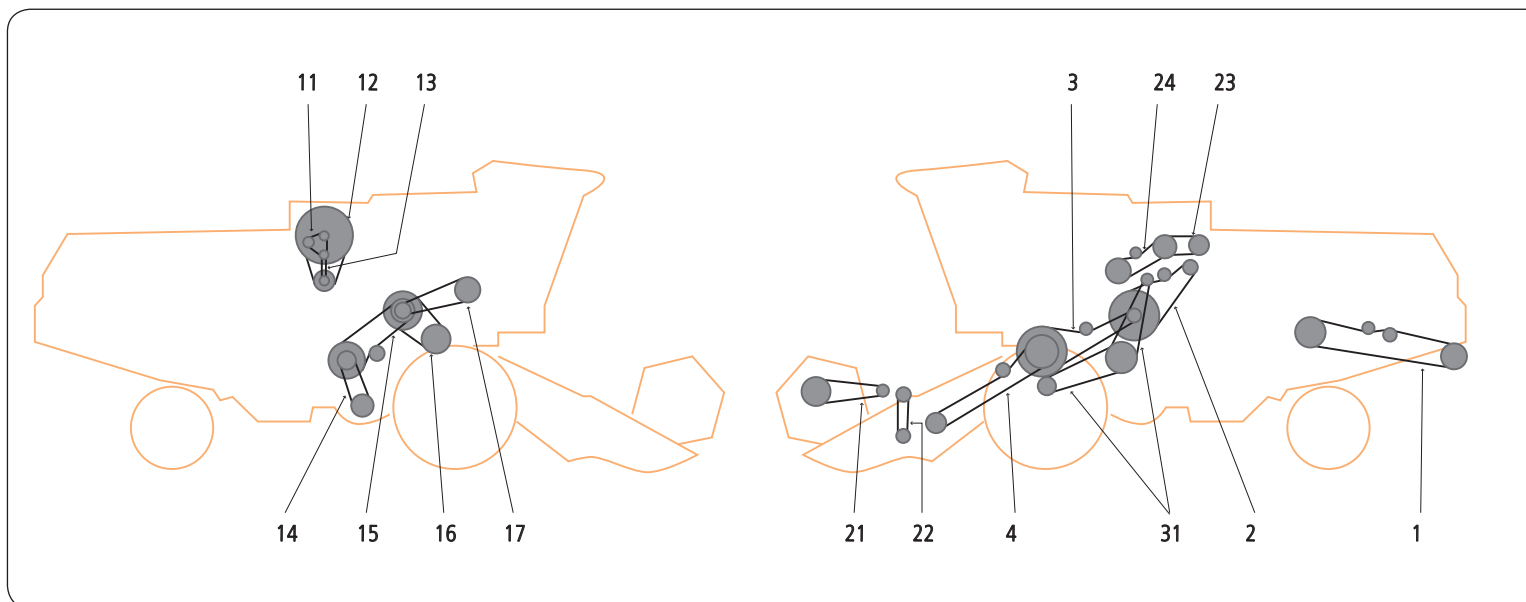

ITEM	APPLICATION	QUANTITY OF V-BELTS IN DRIVE	OE PART NUMBER	COMMENT
1	STRAW WALKER	1	Z33774	
2		1	Z46222	
2	CUTTING TABLE LEAD-IN	1	Z31191	
3	LEAD-IN DRIVE	1	Z38186	
3	LEAD-IN DRIVE	1	Z20460	
3	LEAD-IN DRIVE	1	Z21501	
4	CUTTING TABLE DRIVE	1	Z23693	
4	CUTTING TABLE DRIVE	1	Z46874	
4	CUTTING TABLE DRIVE	1	Z39313	
11	FAN BELT	1	T20334	X
12	ROTARY SCREEN DRIVE	1	Z31283	
13	ROTARY SCREEN DRIVE	1	Z32190	X
14	FAN VARI-DRIVE	1	Z41178	X
15	FAN VARI-DRIVE	1	Z34405	
16		1	Z53288	
17	ELEVATOR DRIVE	1	Z20743	
21		1	Z44740	
22	REEL VARI-DRIVE	1	Z36813	X
23	HYDRAULIC PUMP	1	Z42382	
24	DISCHARGE DRIVE	1	Z43253	
31	MAIN DRIVE	1	Z36120	X

X - not in standard offer

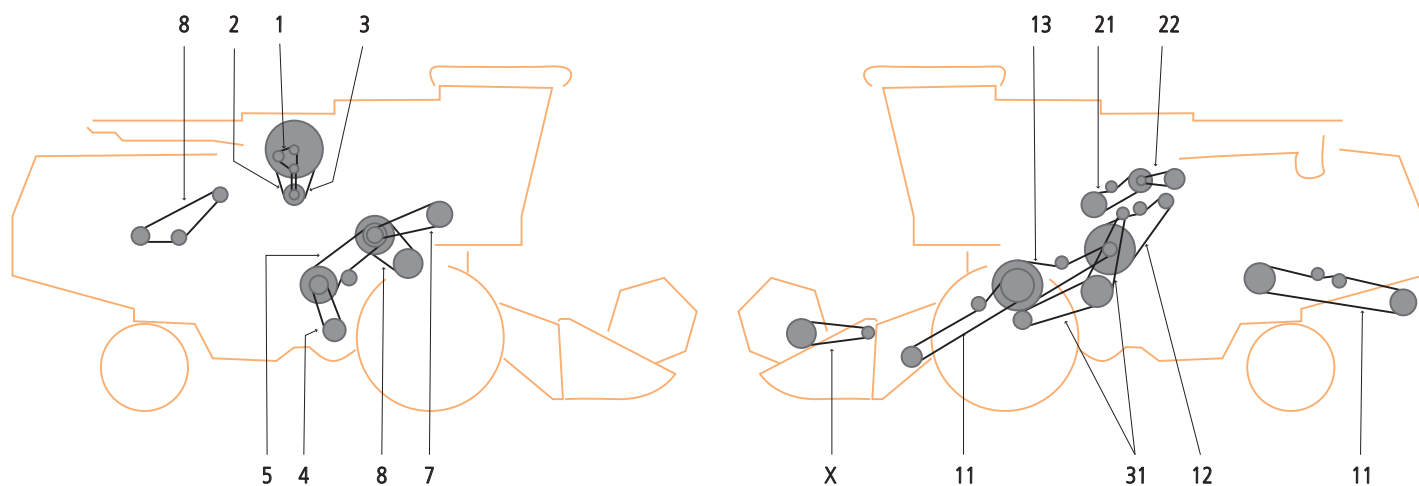

ITEM	APPLICATION	QUANTITY OF V-BELTS IN DRIVE	OE PART NUMBER	COMMENT
1	FAN BELT	1	AT28030	
2	ROTARY SCREEN DRIVE	1	Z31283	
3	ROTARY SCREEN DRIVE	1	Z32190	X
4	FAN VARI-DRIVE	1	Z41178	X
5	FAN VARI-DRIVE	1	Z34405	
6		1	Z53288	
7	ELEVATOR DRIVE	1	Z20743	
8		1	Z35965	
11	STRAW WALKER	1	Z33774	
12		1	Z46222	
12		1	Z21403	
13	LEAD-IN DRIVE	1	Z38186	
13	LEAD-IN DRIVE	1	Z21501	
14	CUTTING TABLE DRIVE	1	Z39312	
14	CUTTING TABLE DRIVE	1	Z39313	
21	DISCHARGE DRIVE	1	Z43253	
22	HYDRAULIC PUMP	1	Z42382	

X - not in standard offer

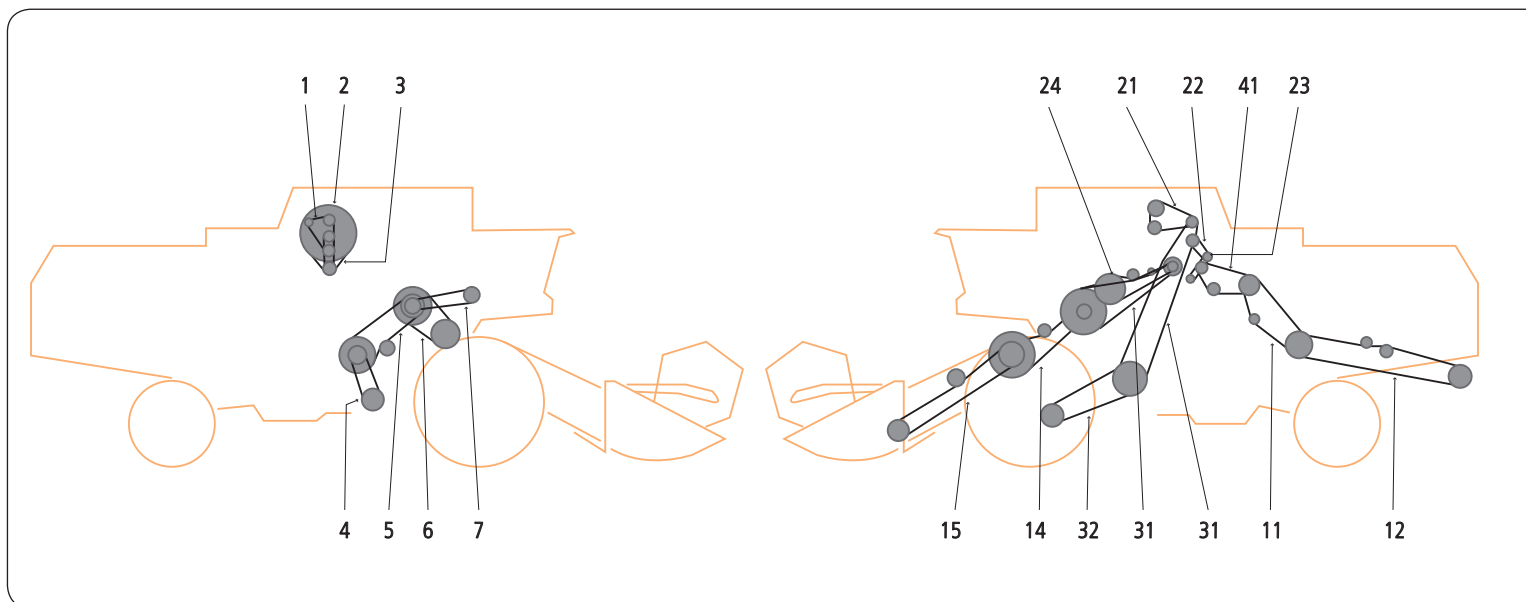

ITEM	APPLICATION	QUANTITY OF V-BELTS IN DRIVE	OE PART NUMBER	COMMENT
1	FAN BELT	1	AR72036	
2	ROTARY SCREEN DRIVE	1	Z34786	
3	ROTARY SCREEN DRIVE	1	Z32190	X
4	FAN VARI-DRIVE	1	Z41178	X
5	FAN VARI-DRIVE	1	Z34405	
6	CYLINDER VARI-DRIVE	1	Z53288	
7		1	Z45026	
11	SHAKER DRIVE	1	Z35965	
12	STRAW WALKER	1	Z33774	
13	CUTTING TABLE LEAD-IN	1	Z33790	
14	LEAD-IN DRIVE (MAIZE)	1	Z38186	
14	LEAD-IN DRIVE (GRAIN)	1	Z21501	
15	CUTTING TABLE DRIVE	1	Z39312	
15	CUTTING TABLE DRIVE	1	Z39313	
15	CUTTING TABLE DRIVE	1	Z39314	
21	AIR CONDITIONING SUB. FOR Z 41 889	1	Z42756	X
22	AIR CONDITIONING (FROM NO 33563)	1	Z45482	
23	HYDRAULIC PUMP	1	Z34828	
24		1	Z47911	
31	MAIN DRIVE (1065)	1	AZ40077	
32	MAIN DRIVE	1	Z34099	X
41		1	Z43863	

X - not in standard offer

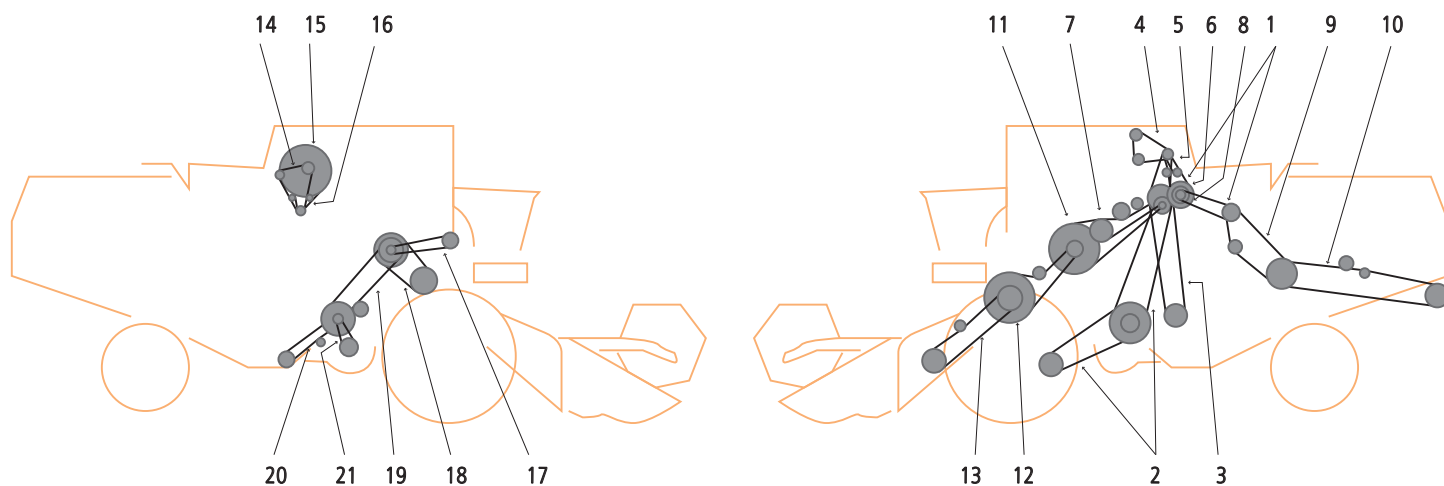

ITEM	APPLICATION	QUANTITY OF V-BELTS IN DRIVE	OE PART NUMBER	COMMENT
3	(1169 HY 4)	1	Z53290	
4	(1169 -AIR COND. WITH SEPARATE CONDENSER COOLING)	1	Z42756	X
5	ONLY 1169	1	Z45482	
6		1	Z34828	
7		1	Z51212	
8	AIR CONDITIONING	1	Z46759	X
9		1	Z35965	
10		1	Z32041	
11		1	Z33790	
12	(GRAIN)	1	Z38186	
12	(MAIZE)	1	Z21501	
13		1	Z39312	
14		1	AR72036	
15		1	Z46764	
16		1	Z32190	X
17		1	Z45026	
18		1	Z20823	
18	SUB FOR Z 20 823	1	Z53288	
19		1	Z46366	
20		1	Z47912	
21		1	Z46365	

X - not in standard offer

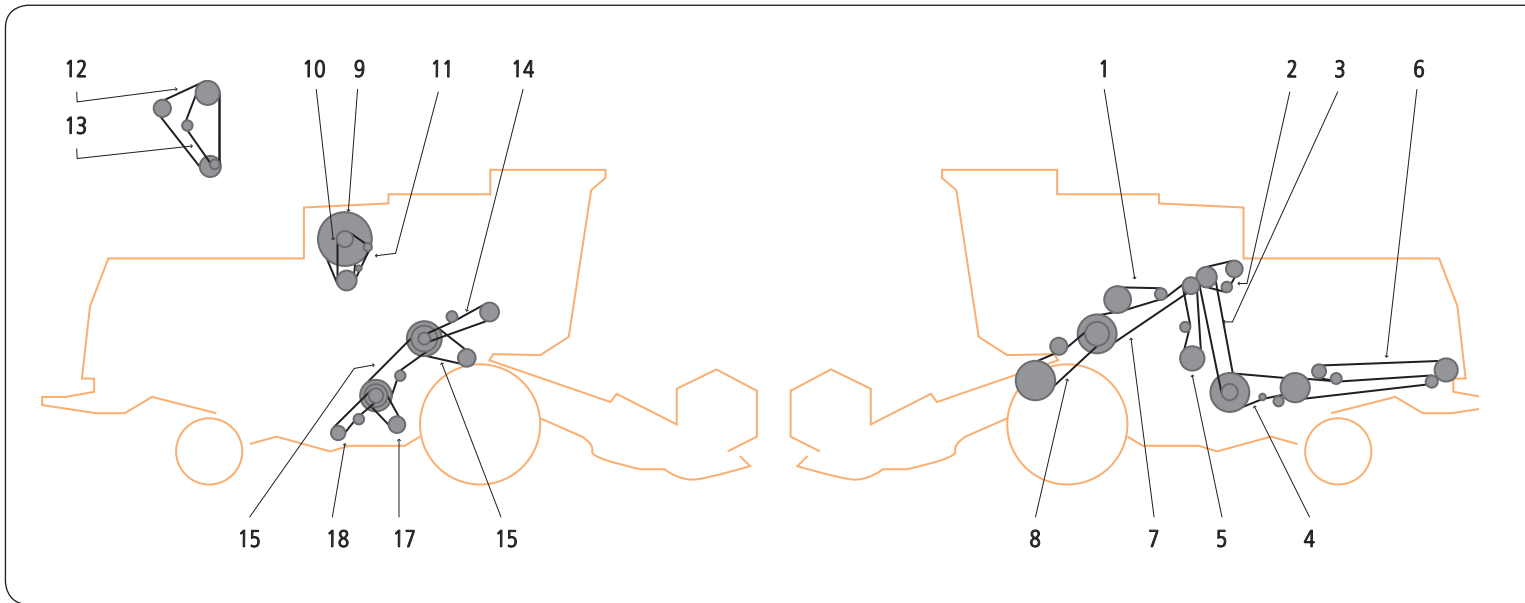

ITEM	APPLICATION	QUANTITY OF V-BELTS IN DRIVE	OE PART NUMBER	COMMENT
5		1	Z46709	
7		1	Z46463	
8		1	Z43890	
13		1	R123451	X
14		1	Z45026	
16		1	Z44936	X
17		1	Z41178	X
19		1	Z46709	

X - not in standard offer

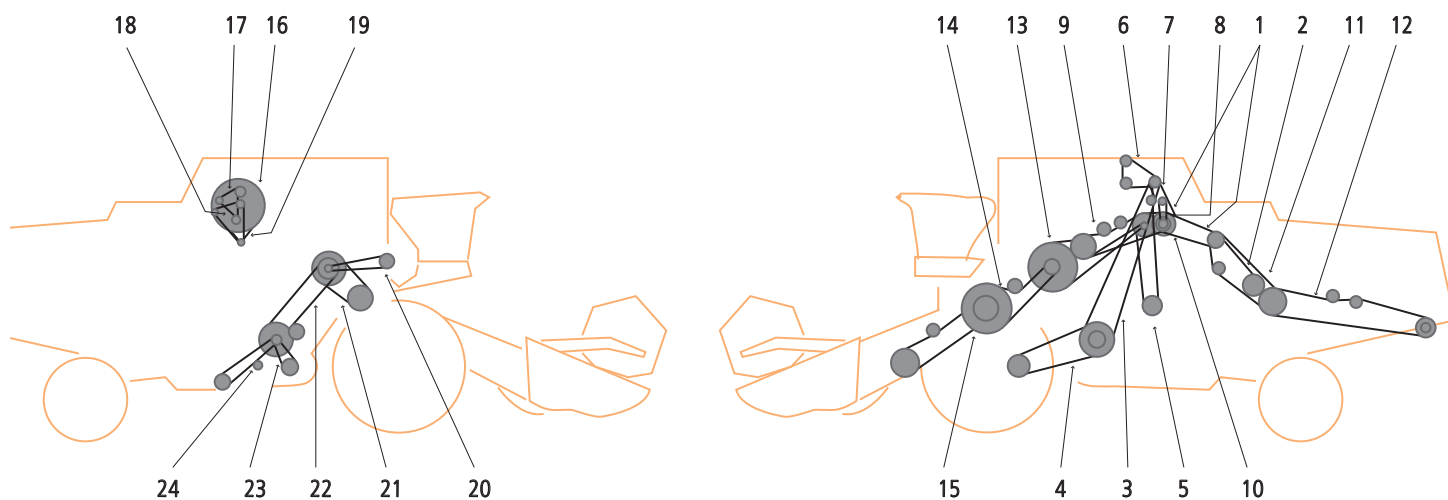

ITEM	APPLICATION	QUANTITY OF V-BELTS IN DRIVE	OE PART NUMBER	COMMENT
1		1	Z43863	
2		1	Z38704	
3	1174 - F. POSI-TORQUE GROUND SPEED DRIVE	1	AZ37807	
4	1174 - F. POSI-TORQUE GROUND SPEED DRIVE	1	Z34099	X
5	1174 HY/4 ONLY	1	Z41728	
6	AIR CONDITIONING WITH SEPARATE CONDENSER COOLING	1	Z42756	X
7		1	Z45482	
8		1	Z34828	
9		1	Z51212	
10	AIR CONDIT. WITH INTEGRATED CONDENSER COOLING	1	Z46759	X
11		1	Z35965	
12		1	Z32041	
13		1	Z33790	
14		1	Z38186	
14		1	Z21501	
15		1	Z39313	
15	FOR FEEDER CONVEYOR. LONG	1	Z39314	
16	1174 ONLY AC WITH INTEGRATED CONDENSER COOLING	1	Z46764	
16	AIR CONDITIONING WITH SEPARATE CONDENSER COOLING	1	Z38704	
17		1	AR72036	
18	1174 HY/4 ONLY	1	Z45367	
19		1	Z32190	X
19		1	Z38692	X
20		1	Z45026	
21		1	Z20823	
21	SUB. FOR Z 20 823	1	Z53288	
21		1	Z44936	X
22		1	Z46366	
23		1	Z46365	
24		1	Z47912	

X - not in standard offer

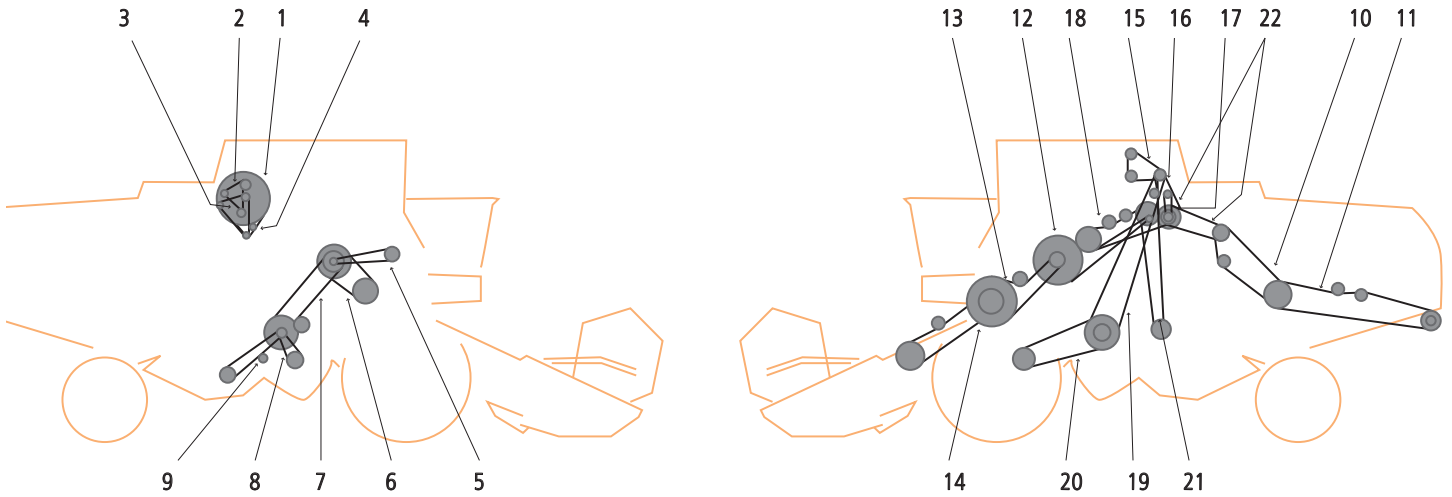

ITEM	APPLICATION	QUANTITY OF V-BELTS IN DRIVE	OE PART NUMBER	COMMENT
0		1	Z51707	
1		1	Z38704	
2		1	H79236	
3		1	Z45367	
4		1	Z38692	X
5		1	Z45026	
6		1	Z44936	X
7		1	Z46366	
8		1	Z46365	
9		1	Z47912	
10		1	Z35965	
11		1	Z32041	
12		1	Z46463	
13		1	Z43890	
14		1	Z43888	
14	FOR FEEDER CONVEYOR LONG	1	Z43889	
15		1	Z42756	X
17		1	Z34828	
18		1	Z51212	
20	1188 ONLY	1	Z34099	X
22		1	Z43863	

X - not in standard offer

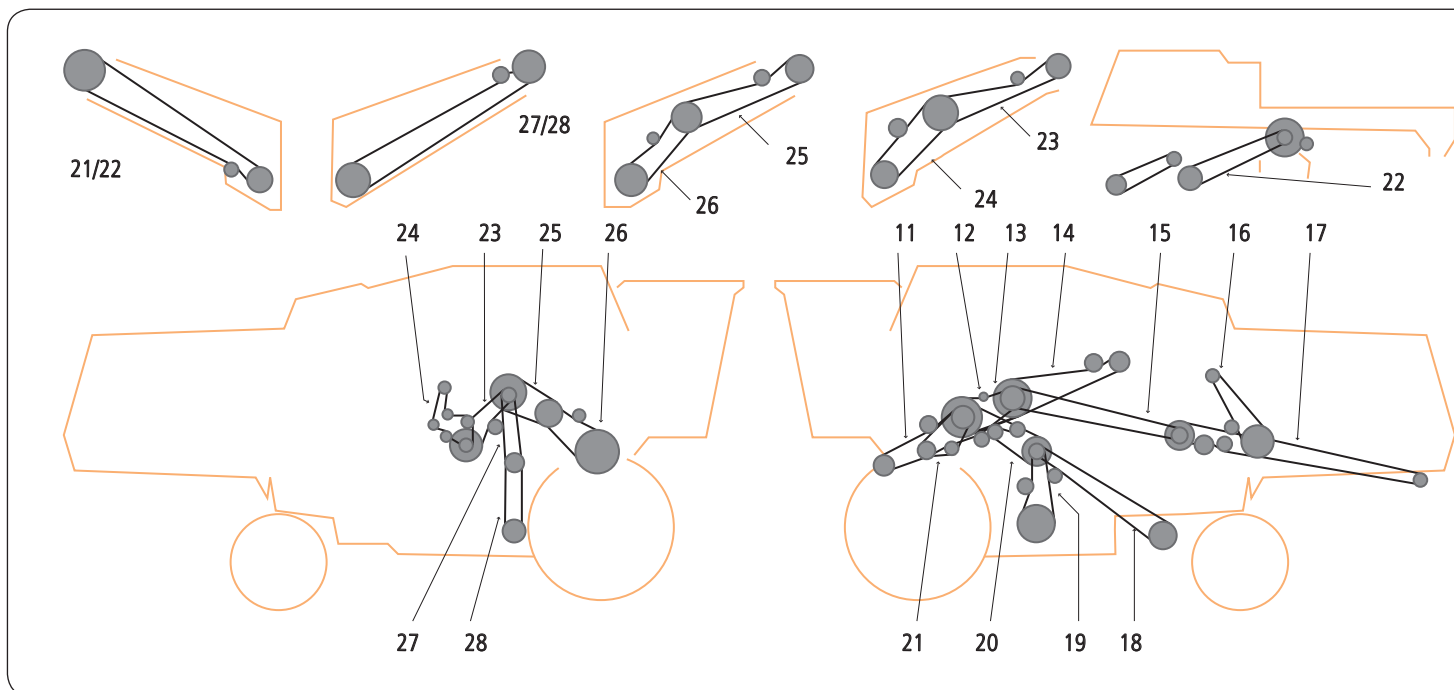

ITEM	APPLICATION	QUANTITY OF V-BELTS IN DRIVE	OE PART NUMBER	COMMENT
1		1	Z54406	
1		1	Z55801	
1		1	Z61151	
2		1	Z58752	
2		1	Z59419	
3		1	Z59556	
3		1	Z63005	
4		1	Z59557	
5		1	Z44936	X
6		1	Z61858	
7		1	Z62110	X
8		1	Z62111	X
11		1	Z59344	X
12		1	Z57084	
13		1	Z64912	X
13		1	Z61150	
13		1	Z52909	X
14		1	Z61857	
15		1	Z59286	
16		1	Z59114	
17		1	Z59342	
18		1	Z60135	
19		1	Z59322	
20		1	Z56959	
21		1	Z56421	
22		1	Z48212	
23		1	Z61152	
23		1	Z60931	
24		1	Z61154	X
24		1	Z62211	X
25		1	Z61152	
25		1	Z60931	
25		1	Z54807	X
25		1	Z58751	
26		1	Z61153	
26		1	Z61827	

ITEM	APPLICATION	QUANTITY OF V-BELTS IN DRIVE	OE PART NUMBER	COMMENT
26		1	Z62213	X
26		1	Z55459	X
27		1	Z61164	
27		1	Z62551	
27		1	Z54406	
27		1	Z62214	
28		1	Z60930	
28		1	Z62552	

X - not in standard offer

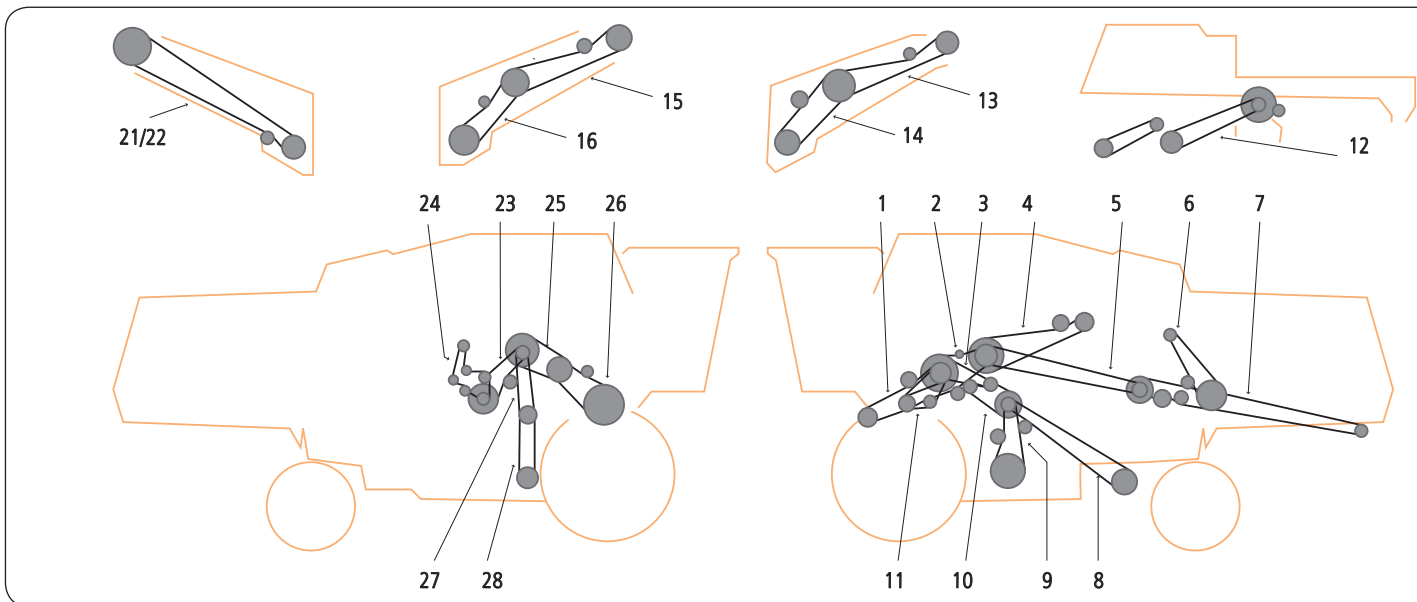

ITEM	APPLICATION	QUANTITY OF V-BELTS IN DRIVE	OE PART NUMBER	COMMENT
1		1	Z59344	X
1		1	Z61151	
2		1	Z57084	
3		1	Z64912	X
3		1	Z61150	
3		1	Z52909	X
4		1	Z61857	
5		1	Z59286	
6		1	Z59114	
7		1	Z59342	
8		1	Z60135	
9		1	Z56421	
10		1	Z56959	
11		1	Z59322	
12		1	Z48212	
12		1	Z59419	
13		1	Z61152	
13		1	Z60931	
14		1	Z61154	X
14		1	Z62211	X
15		1	Z61152	
15		1	Z60931	
15		1	Z54807	X
15		1	Z58751	
16		1	Z61153	
16		1	Z61827	
16		1	Z62213	X
16		1	Z55459	X
21		1	Z55801	
21		1	Z54406	
22		1	Z58752	
22		1	Z59419	
23		1	Z59556	
23		1	Z63005	
24		1	Z59557	
25		1	Z44936	X
26		1	Z61858	
27		1	Z62110	X
28		1	Z62111	X

X - not in standard offer

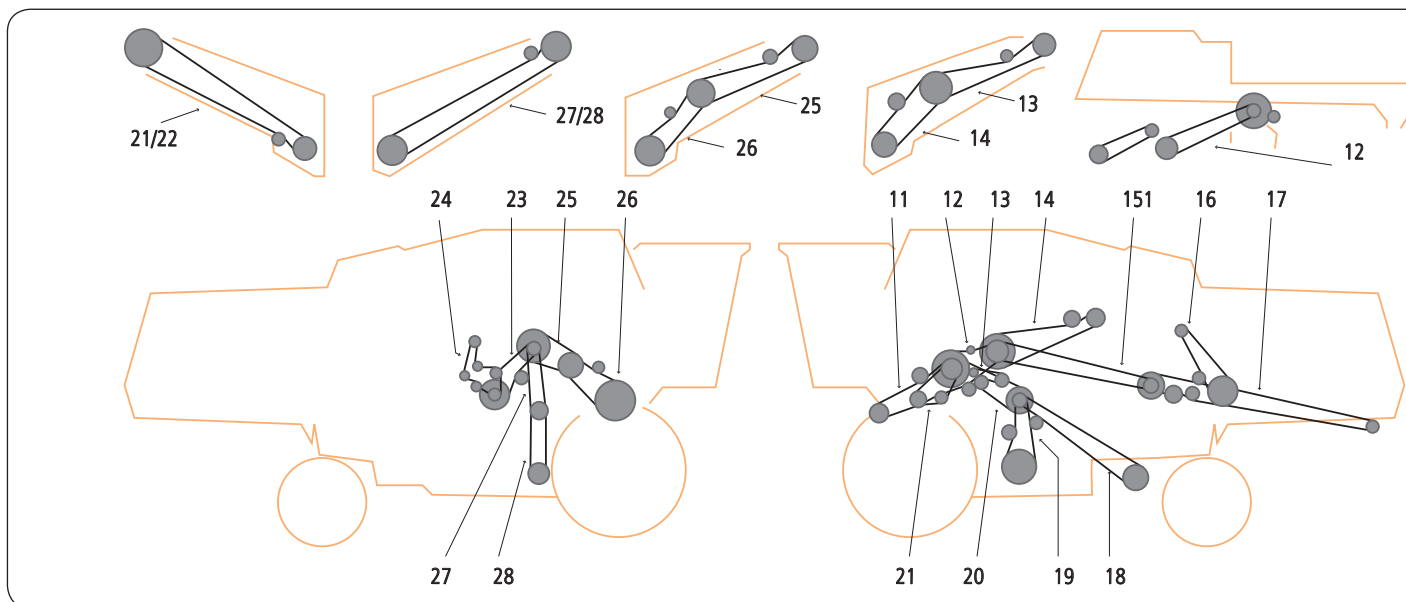

ITEM	APPLICATION	QUANTITY OF V-BELTS IN DRIVE	OE PART NUMBER	COMMENT
1		1	Z59344	X
1		1	Z61151	
2		1	Z57084	
3		1	Z64912	X
3		1	Z61150	
4		1	Z61857	
5		1	Z59286	
6		1	Z59114	
7		1	Z59342	
8		1	Z60135	
9		1	Z59322	
10		1	Z56959	
11		1	Z56421	
12		1	Z48212	
13		1	Z61152	
13		1	Z60931	
14		1	Z62211	X
15		1	Z61152	
15		1	Z60931	
15		1	Z54807	X
15		1	Z58751	
16		1	Z61827	
16		1	Z62213	X
17		1	Z62551	
17		1	Z54406	
18		1	Z62552	
18		1	Z62214	
21		1	Z54406	
22		1	Z59419	
23		1	Z63005	
24		1	Z59557	
25		1	Z44936	X
26		1	Z61858	
27		1	Z62110	X
28		1	Z62111	X

X - not in standard offer

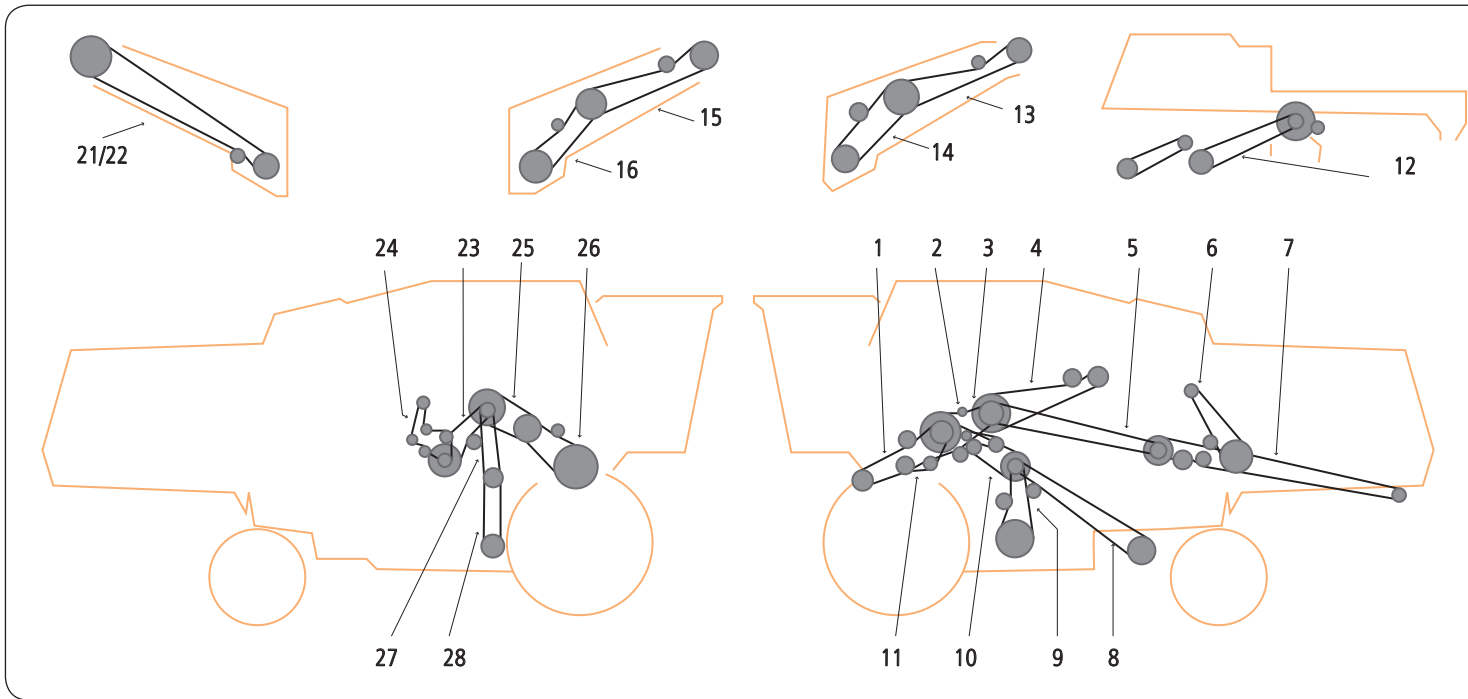

ITEM	APPLICATION	QUANTITY OF V-BELTS IN DRIVE	OE PART NUMBER	COMMENT
1		1	Z59344	X
1		1	Z61151	
2		1	Z57084	
3		1	Z64912	X
3		1	Z61150	
4		1	Z61857	
5		1	Z59286	
6		1	Z59114	
7		1	Z59342	
8		1	Z60135	
9		1	Z56421	
10		1	Z56959	
11		1	Z59322	
12		1	Z48212	
13		1	Z61152	
13		1	Z60931	
14		1	Z62211	X
15		1	Z61152	
15		1	Z60931	
15		1	Z54807	X
15		1	Z58751	
16		1	Z61827	
16		1	Z62213	X
21		1	Z54406	
22		1	Z59419	
23		1	Z63005	
24		1	Z59557	
25		1	Z44936	X
26		1	Z61858	
27		1	Z62110	X
28		1	Z62111	X

X - not in standard offer

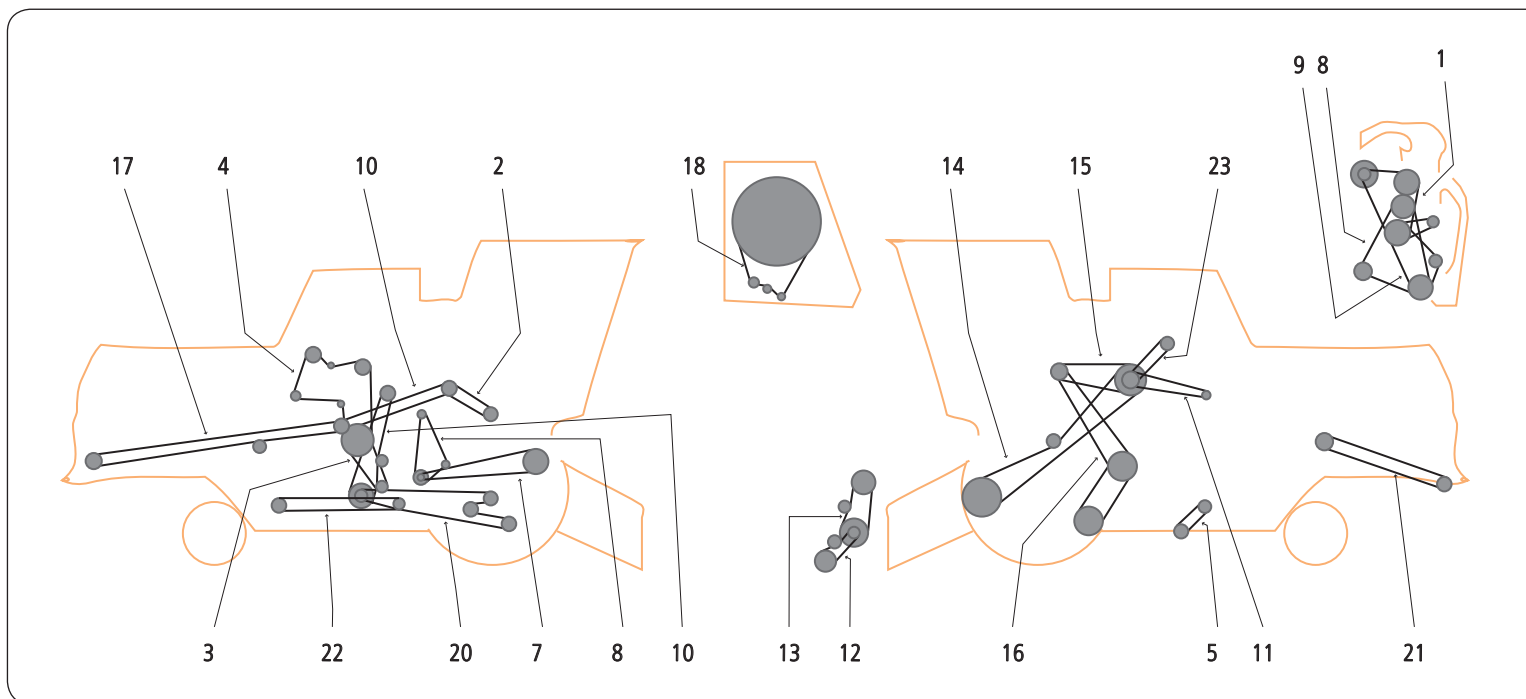

ITEM	APPLICATION	QUANTITY OF V-BELTS IN DRIVE	OE PART NUMBER	COMMENT
1	ALTERNATOR AND PUMP	1	J101813	X
1	ALTERNATOR AND WATER PUMP	1	H82724	
2	COMPRESSOR. AIR CONDITIONING	1	H86275	X
3	ENGINE FAN (CAB WITHOUT AIR CONDITIONING)	1	H86271	
3	ENGINE FAN (CAB WITH AIR CONDITONER)	1	H94373	X
4	ENGINE FAN AND ROTARY SCREEN DRIVE SHAFT	1	H86275	X
5	ROTARY SCREEN	1	H86259	X
6	PRIMARY COUNTERSHAFT	2	AH98052	
8	UNLOADING AUGER COUNTERSHAFT	1	H76136	
9	CLEANING FAN	1	H80726	
10	STRAW SPREADER	1	H80159	
11	HYDROSTATIC REEL PUMP	1	H77683	X
12	PLATFORM AND FEEDER HOUSE UPPER	1	H76028	
13	PLATFORM AND CORN HEAD MIDDLE VARIABLE	1	P46553	X
14	PLATFORM AND CORN HEAD LOWER VARIABLE	1	AH87197	
14	PLATFORM RICE. GRAIN. CORN FEEDER HOUSE	1	AH76154	
15	BEATER	1	H101352	
15	BEATER	1	H86039	
16	SHOE GRAIN SUPPLY AUGERS	1	H79285	
17	CLEAN GRAIN ELEVATOR	1	H81222	
18	CLEAN GRAIN ELEVATOR COUNTERSHAFT	1	H23817	
20	CYLINDER	1	AH80500	
21	TAILINGS LOWER AUGER	1	E63031	
22	REAR STRAW CHOPPER	1	H79787	
23	FRONT STRAW CHOPPER	1	H20407	
24	SECONDARY COUNTERSHAFT	1	H138762	
14	STRAW SPREADER	1	Z33774	
15	BEATER	1	Z33790	
16	FEEDER HOUSE	1	Z38186	
17	FRONT SRAW CHOPPER	1	Z44761	
18	REAR STRAW CHOPPER	1	Z44930	
x			H87296	X

X - not in standard offer

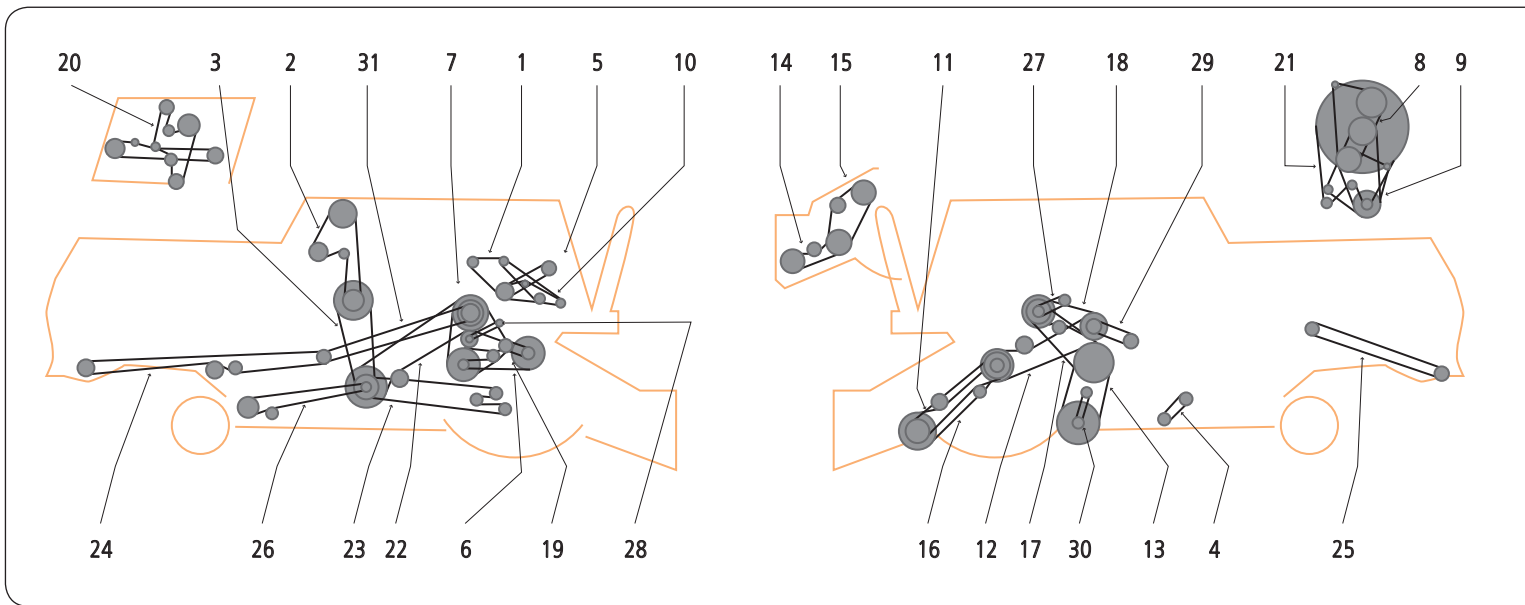

ITEM	APPLICATION	QUANTITY OF V-BELTS IN DRIVE	OE PART NUMBER	COMMENT
5	COMPRESSOR. AC	1	H87459	X
5	COMPRESSOR. AC	1	R71603	
9	ENGINE FAN AND ROTARY SCREEN DRIVE SHAFT	1	H137207	
17	PROPULSION POSI-TORQUE UPPER	2	AH21301	
17	PROPULSION POSI-TORQUE UPPER	2	AH87127	X
18	PRIMARY COUNTERSHAFT	1	H84462	
18	PRIMARY COUNTERSHAFT	1	H108175	
27	UNLOADING AUGER COUNTERSHAFT	1	H76150	
27	UNLOADING AUGER COUNTERSHAFT	1	H84424	X

X - not in standard offer

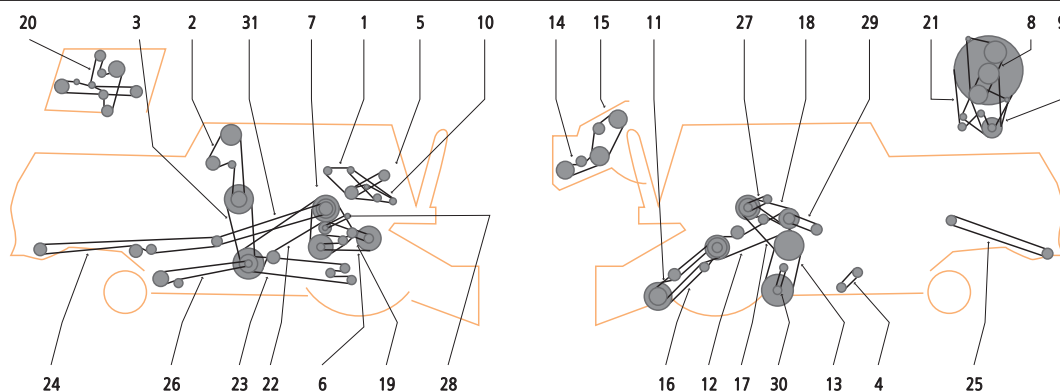

ITEM	APPLICATION	QUANTITY OF V-BELTS IN DRIVE	OE PART NUMBER	COMMENT
1	SICKLE DRIVE	1	856559	
1	ALTERNATOR & WATER PUMP	1	H82724	
1	PRIMARY COUNTERSHAFT	2	AH75638	
2	U-JOINT LOADING AUGER	1	H23950	
2	SICKLE DRIVER	1	857862	
3	CLEAN GRAIN ELEVATOR COUNTERSHAFT	1	H27433	
4	CLEANING FAN	1	H108668	
5	COMPRESSOR. AC	1	H80896	
6	CYLINDER 280-845 RPM	1	AH80505	
6	CYLINDER 407-828 RPM	1	AH80503	
6	CYLINDER 287-873 RPM SLOW SPEED INT SPD	1	H96423	
7	CYLINDER. INTERMEDIATE SHAFT	1	H113749	X
8	ENGINE FAN 6404DH	1	H86271	
8	ENGINE FAN 6329GH-02 & 6329DH-01	1	H86272	X
11	FEEDER CONVEYOR (REGULAR FEEDER HOUSE)	1	H77766	
11	FEEDER CONVEYOR (LONG FEEDER HOUSE)	1	H125380	
12	PLATFORM & FEEDER HOUSE UPPER	1	H76030	X
12	PLATFORM & FEEDER HOUSE VARI-SPEED UPPER	1	H23927	
13	PROPULSION HYDROSTATIC DRIVE LOWER	2	AH84633	
13	PROPULSION HYDROSTATIC DRIVE LOWER	1	H88576	X
13	PROPULSION POSI-TORQUE LOWER	1	H75846	X
14	PLATFORM & CORN HEAD	1	AH76154	
15	PLATFORM & CORN HEAD MIDDLE VARIABLE	1	P46553	X
15	PLATFORM & CORN HEAD MIDDLE VARIABLE	1	H84441	X
16	PLATFORM & FEEDER HOUSE LOWER REGULAR	1	H77765	
16	PLATFORM & FEEDER HOUSE LOWER LONG	1	H79796	
17	PROPULSION HYDROSTATIC DRIVE UPPER	2	AH84633	
17	PROPULSION POSI-TORQUE UPPER	2	AH21301	
17	PROPULSION HYDROSTATIC DRIVE UPPER	1	H88576	X
18	PRIMARY COUNTERSHAFT	1	H84462	
19	ROTARY REFLECTOR	1	H86039	
19	ROTARY DEFLECTOR	1	H86061	
20	CLEAN GRAIN ELEVATOR	1	H77766	
21	ROTARY SCREEN	1	H86259	X
22	SECONDARY COUNTERSHAFT	1	H77019	
23	SHOE GRAIN SUPPLY AUGERS	1	H77010	
24	STRAW CHOPPER. REAR	1	H79789	
25	STRAW SPREADER	1	H26858	
26	TAILINGS LOWER AUGER	1	N110085	
29	HYDROSTATIC REEL PUMP	1	H77683	X
30	CHARGE PUMP. HYDROSTATIC DRIVE	1	T12042	X
30	CHARGE PUMP. HYDROSTATIC DRIVE	1	T199T	X
31	STRAWCHOPPER	1	H80103	
x	6404DH	1	H85377	X
x		1	H75846	X

X - not in standard offer

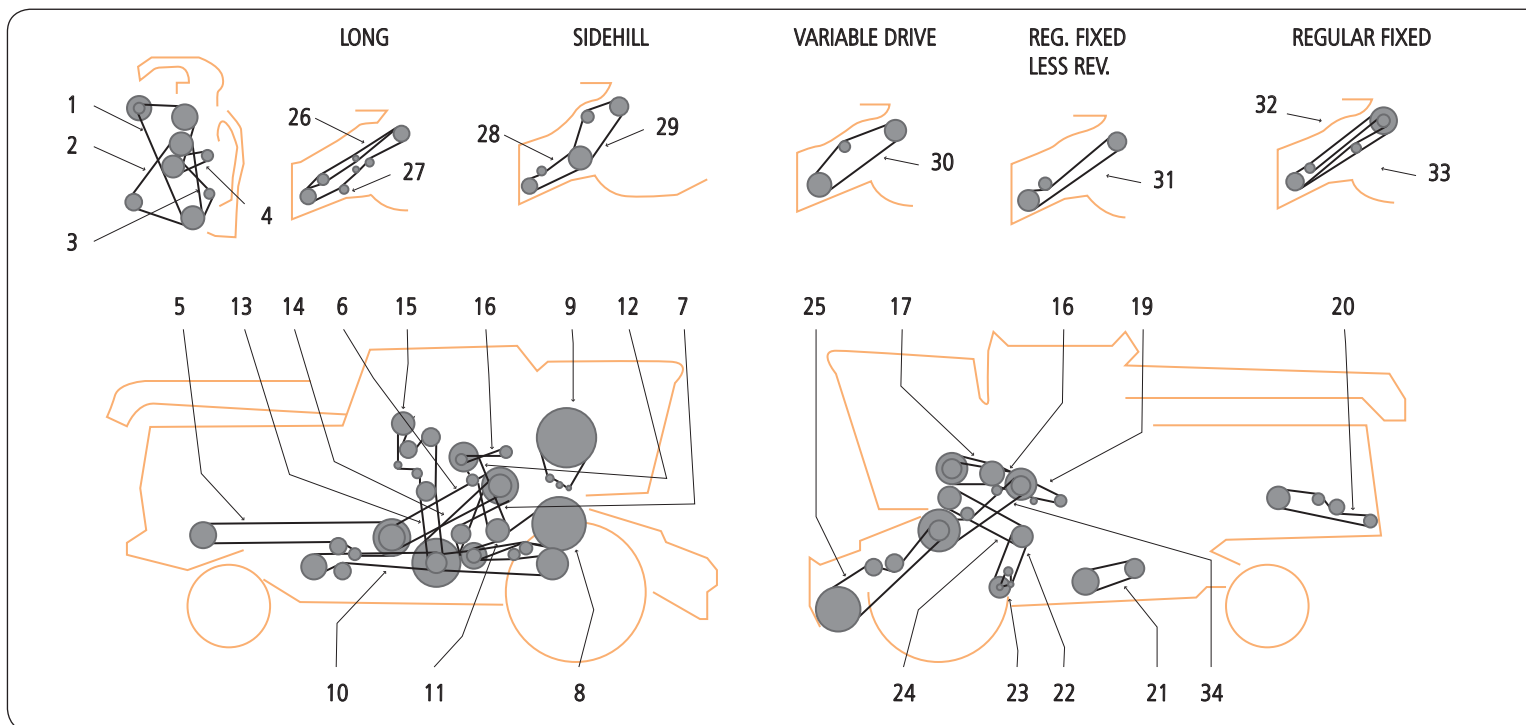

ITEM	APPLICATION	QUANTITY OF V-BELTS IN DRIVE	OE PART NUMBER	COMMENT
0	DRIVE. TORQUE-SENSING COUNTERSHAFT	1	H113749	X
0	DRIVE. UPPER COUNTERSHAFT 2480 MM	1	P49415	
1	ALTERNATOR AND WATER PUMP	1	H79236	
2	ROTARY SCREEN DRIVE SHAFT	1	H86273	
3	ENGINE FAN	1	H86272	X
4	COMPRESSOR. AIR CONDITIONING (S/N >600000)	1	H113565	
4	COMPRESSOR. AIR CONDITIONING (S/N <600001)	1	R71603	
5	REAR STRAW CHOPPER DRIVE	1	H103344	
6	STRAW CHOPPER DRIVE	1	H101436	
7	DRIVE. LOWER COUNTERSHAFT 2650 MM	1	E60212	
8	CYLINDER. 3- BANDED (315 TO 830 RPM) (S/N <551900)	1	H96423	
8	CYLINDER. 3-BANDED (S/N <551900)	1	H96408	
8	CYLINDER. 4-BANDED (OPTIONAL) (S/N >551899)	1	H96422	
8	CYLINDER. 4-BANDED (STANDARD) (S/N >551899)	1	H110375	
9	ROTARY SCREEN	1	H86259	X
10	DRIVE. TAILINGS AUGER	1	H118730	
11	DRIVE. SHOE SUPPLY AUGERS	1	H77010	
12	BEATER (100 PERCENT BEATER SPEED)	1	H96414	
12	BEATER (150 PERCENT BEATER SPEED)	1	H101469	
13	CLEAN GRIAN ELEVATOR COUNTERSHAFT	1	H27433	
14	DRIVE. SECONDARY COUNTERSHAFT	1	H81222	
14	DRIVE. SECONDARY COUNTERSHAFT	1	H110300	
15	DRIVE. CLEAN GRAIN ELEVATOR AND LOADING	1	H77766	
17	UNLOADING AUGER DRIVE	2	AH96300	
18	MULTI-GROOVE SEPARATOR DRIVE	1	H108175	
19	HYDRAULIC REEL PUMP	1	H86275	X
19	HYDRAULIC REEL PUMP	1	H137207	
20	FRONT STRAW SPREADER DRIVE	1	H112421	
21	CLEANING FAN DRIVE	1	H108668	
22	LOWER GROUND DRIVE (MATCHED SET)	2	AH84633	
22	LOWER GROUND DRIVE	1	H75846	X
23	DRIVE. HYDROSTATIC CHARGE PUMP (S/N > 610300)	1	T32517	X
23	DRIVE. HYDROSTATIC CHARGE PUMP (S/N <610300)	1	T199T	X
24	UPPER GROUND DRIVE (MATCHED SET)	2	AH84633	
24	POSI-TORQUE UPPER GROUND DRIVE (MATCHED SET)	2	AH87127	X
25	FEEDER HOUSE DRIVE (REGULAR) (S/N 502551 - 615100)	1	H111519	

ITEM	APPLICATION	QUANTITY OF V-BELTS IN DRIVE	OE PART NUMBER	COMMENT
26	FEEDER CONVEYOR DRIVE (S/N <403301)	1	H125380	
27	FEEDER HOUSE, LOWER, LONG (S/N <403301)	1	H79796	
28	MULTI-GROOVE (SIDEHILL ONLY) (MATCHED SET)	1	AH89436	
29	FEEDER HOUSE, LOWER, LONG (S/N >403300)	1	H97929	
29	FEEDER HOUSE, UPPER (SIDEHILL ONLY) (S/N <610300)	1	H84441	X
30	FEEDER HOUSE DRIVE CONVEYOR	1	H110921	X
30	FEEDER H., LOWER FIXED LESS REVERS. (S/N >61030)	1	H116422	X
31	FEEDER H., LOWER FIXED LESS REVERSER (S/N >615100)	1	Z30130	
32	FEEDER HOUSE, LOWER, REG. FIXED (S/N >502550)	1	H77765	
33	FEEDER HOUSE CONVEYOR, REG. FIXED (S/N >502550)	1	H77766	
34	FEEDER HOUSE, LESS REVERSER (S/N >615100)	1	H76030	X
34	FEEDER HOUSE, REVERSER, VARI-DRIVE	1	H23927	

X - not in standard offer

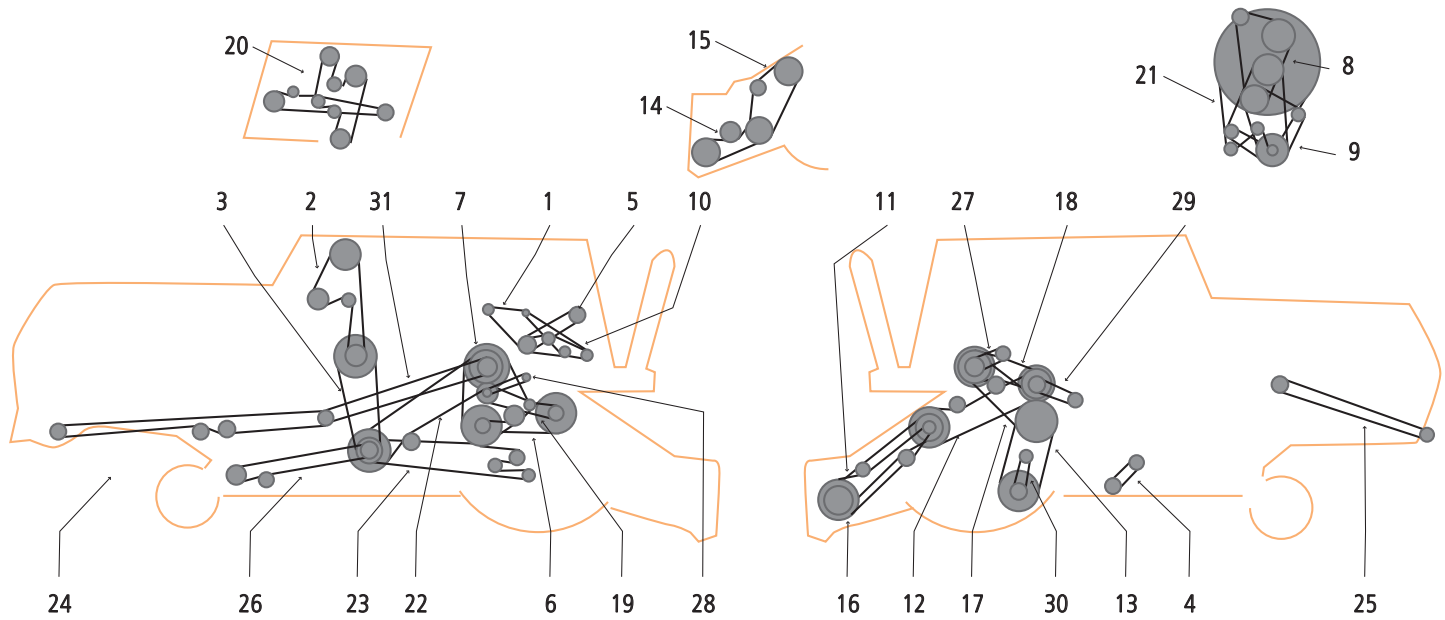

ITEM	APPLICATION	QUANTITY OF V-BELTS IN DRIVE	OE PART NUMBER	COMMENT
1	ALTERNATOR AND WATER PUMP	1	H79236	
2	COMPRESSOR. AIR CONDITIONING	1	H113565	
2	COMPRESSOR. AIR CONDITIONING	1	R71603	
3	FAN	1	H86271	
4	ROTARY SCREEN DRIVE SHAFT	1	H86273	
5	ROTARY SCREEN	1	H86259	X
6	DRIVE. UPPER COUNTERSHAFT 2480 MM	1	P49415	
7	DRIVE. LOWER COUNTERSHAFT 2650 MM	1	E60212	
8	REAR STRAW CHOPPER DRIVE	1	H103344	
9	STRAW CHOPPER DRIVE	1	H101436	
10	DRIVE. TORQUE-SENSING COUNTERSHAFT	1	H113749	X
11	CYLINDER 3-BANDED (315 TO 830 RPM)	1	H96423	
11	CYLINDER 4-BANDED (OPTIONAL)	1	H96422	
11	CYLINDER 4-BANDED (STANDARD)	1	H110375	
12	CYLINDER. 3-BANDED	1	H96408	
12	DRIVE. CLEAN GRAIN ELEVATOR AND LOADING	1	H77766	
13	CLEAN GRAIN ELEVATOR COUNTERSHAFT	1	H27433	
14	DRIVE. SECONDARY COUNTERSHAFT	1	H81222	
14	DRIVE. SECONDARY COUNTERSHAFT	1	H110300	
15	DRIVE. SHOE SUPPLY AUGERS	1	H77010	
16	DRIVE. TAILINGS AUGER	1	H118730	
17	BEATER (100 PERCENT BEATER SPEED)	1	H96414	
17	BEATER (150 PERCENT BEATER SPEED)	1	H101469	
18	FEEDER HOUSE DRIVE	1	H76030	X
19	FEEDER CONVEYOR DRIVE	1	H125380	
20	FEEDER HOUSE LOWER DRIVE	1	H79796	
21	FEEDER HOUSE DRIVE	1	H76030	X
22	FEEDER CONVEYOR DRIVE	1	H77766	
23	LOWER DRIVE	1	H77765	
24	UNLOADING AUGER DRIVE	2	AH96300	
25	FEEDER HOUSE DRIVE	1	H23927	
26	FEEDER HOUSE LOWER DRIVE (REGULAR)	1	H111519	
26	FEEDER HOUSE LOWER DRIVE (LONG)	1	H97929	
27	MULTI-GROOVE SEPARATOR DRIVE	1	H108175	
28	FEEDER HOUSE DRIVE	1	H76030	X

ITEM	APPLICATION	QUANTITY OF V-BELTS IN DRIVE	OE PART NUMBER	COMMENT
29	LOWER DRIVE	1	Z30130	
30	CLEANING FAN DRIVE	1	H108669	
31	FEEDER HOUSE DRIVE CONVEYOR	1	H110921	X
32	FEEDER HOUSE DRIVE	1	H23927	
33	FRONT STRAW SPREADER DRIVE	1	H112421	
34	UPPER GROUND DRIVE (MATCHED SET)	2	AH87127	X
35	LOWER GROUND DRIVE	1	H75846	X
36	UPPER GROUND DRIVE (MATCHED SET)	2	AH84633	
37		1	H137207	
38	LOWER GROUND DRIVE (MATCHED SET)	2	AH84633	
39	DRIVE. HYDROSTATIC CHARGE PUMP	1	T32517	X
39	DRIVE. HYDROSTATIC CHARGE PUMP	1	T199T	X

X - not in standard offer

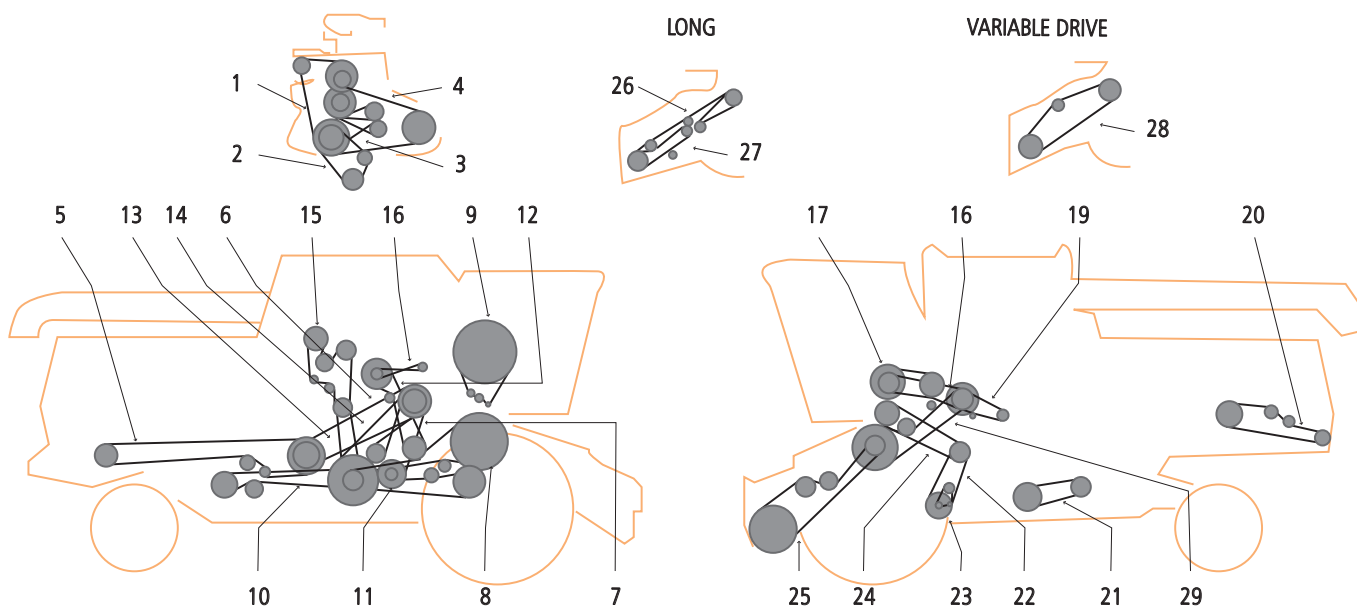

ITEM	APPLICATION	QUANTITY OF V-BELTS IN DRIVE	OE PART NUMBER	COMMENT
1	FAN AND HYDRAULIC PUMP (MATCHED SET)	1	AH96333	
2	COMPRESSOR	1	R71603	
3	ROTARY SCREEN	1	H86273	
4	ALTERNATOR AND WATER PUMP	1	H79236	
4	ALTERNATOR AND WATER PUMP	1	H86271	
5	ROTARY SCREEN	1	H86259	X
6	REAR STRAW CHOPPER DRIVE	1	H103344	
7	STRAW CHOPPER DRIVE	1	H101436	
8	DRIVE. TORQUE-SENSING COUNTERSHAFT	1	H113749	X
9	CYLINDER. 4-BANDED (315 TO 830 RPM)	1	H96421	
9	CYLINDER. 4-BANDED (OPTIONAL)	1	H96422	
9	CYLINDER. 4-BANDED (STANDARD)	1	H110375	
10	DRIVE. CLEAN GRAIN ELEVATOR AND LOADING	1	H77766	
11	CLEAN GRAIN ELEVATOR COUNTERSHAFT	1	H27433	
12	DRIVE. SECONDARY COUNTERSHAFT	1	H81222	
12	DRIVE. SECONDARY COUNTERSHAFT	1	H110300	
13	DRIVE. SHOE SUPPLY AUGERS	1	H77010	
14	DRIVE. TAILINGS AUGER	1	H118730	
15	BEATER (100 PERCENT BEATER SPEED)	1	H96414	
15	BEATER (150 PERCENT BEATER SPEED)	1	H101469	
16	FEEDER HOUSE DRIVE	1	H76030	X
17	FEEDER CONVEYOR DRIVE	1	H125380	
18	FEEDER HOUSE LOWER DRIVE	1	H79796	
19	UNLOADING AUGER DRIVE	2	AH96300	
20	FEEDER HOUSE DRIVE	1	H23927	
21	FEEDER HOUSE LOWER DRIVE	1	H97929	
22	MULTI-GROOVE SEPARATOR DRIVE	1	H108175	
23	FEEDER HOUSE DRIVE	1	H76030	X
24	LOWER DRIVE	1	H79796	
25	CLEANING FAN DRIVE	1	H108669	
26	FEEDER HOUSE DRIVE CONVEYOR	1	H110921	X
27	FEEDER HOUSE DRIVE	1	H23927	
28	FRONT STRAW SPREADER DRIVE	1	H112421	
29	UPPER GROUND DRIVE (MATCHED SET)	2	AH84633	
30		1	H86275	X
30		1	H137207	
31	LOWER GROUND DRIVE (MATCHED SET)	2	AH84633	
32	DRIVE. HYDROSTATIC CHARGE PUMP	1	T32517	X

X - not in standard offer

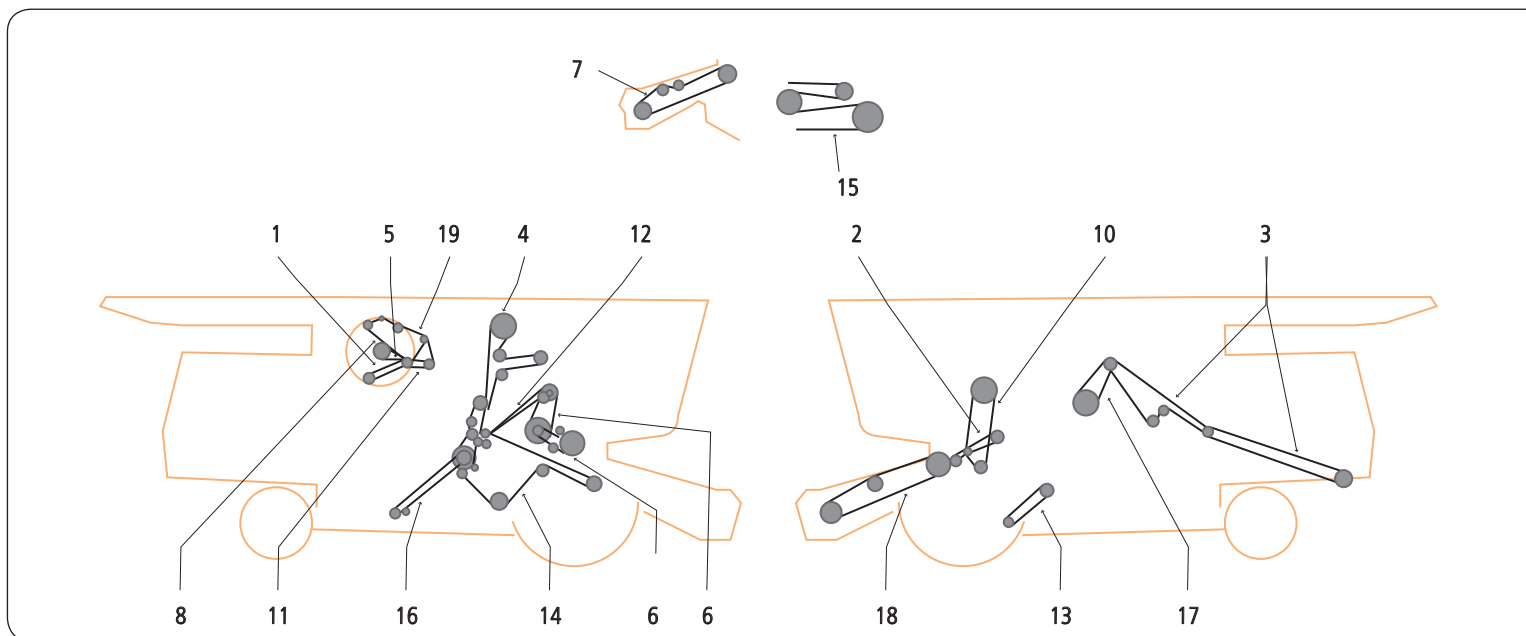

ITEM	APPLICATION	QUANTITY OF V-BELTS IN DRIVE	OE PART NUMBER	COMMENT
1	COOLING FAN	1	H132809	
2	ROTARY SCREEN	1	H143869	X
3	ROTARY SCREEN DRIVE	1	H134216	X
4	AIR CONDITIONING COMPRESSOR	1	H134772	
5	CLEAN GRAIN ELEVATOR	1	H137830	
6	CYLINDER INTERMEDIATE DRIVE	1	H115759	X
6	CLEAN GRAIN ELEVATOR	1	H141167	
6	FOR EXTENDED RANGE	1	H137670	X
7	CYLINDER DRIVE SLOW SPEED	1	H118618	X
7	CYLINDER DRIVE REGULAR DUAL RANGE AND SI	1	H115881	
8	LOWER TAILINGS AUGER AND ELEVATOR	1	N110085	
9	FOR ALTERNATOR. MATCHED SET OF 2	1	H145026	
9	FOR ALTERNATOR. MATCHED SET OF 2	1	RE44538	X
10	SECONDARY COUNTERSHAFT	1	H128010	
11	SHOE. SRAW WALKER AND CONVEYOR AUGERS	1	H131169	
12	UNLOADING SYSTEM	1	AH127866	
13	SHORT REAR	1	L4276N	
13	LONG REAR	1	H101436	
13	FRONT	1	H125380	
14	REGULAR	1	H140404	
14	SLOW SPEED	1	H137264	X
15	HEADER AND REEL PUMP	1	H125565	
15	HEADER AND REEL PUMP	1	H140160	
16	VARIABLE SPEED FEEDER HOUSE	1	H125711	X
17	BEATER (75 PERCENT)	1	AH131960	
17	BEATER (100 PERCENT)	1	AH139436	
18	FIXED SPEED FEEDER HOUSE WITH REVERSER	1	H126345	
19	STRAW SPREADER	1	Z33774	

X - not in standard offer

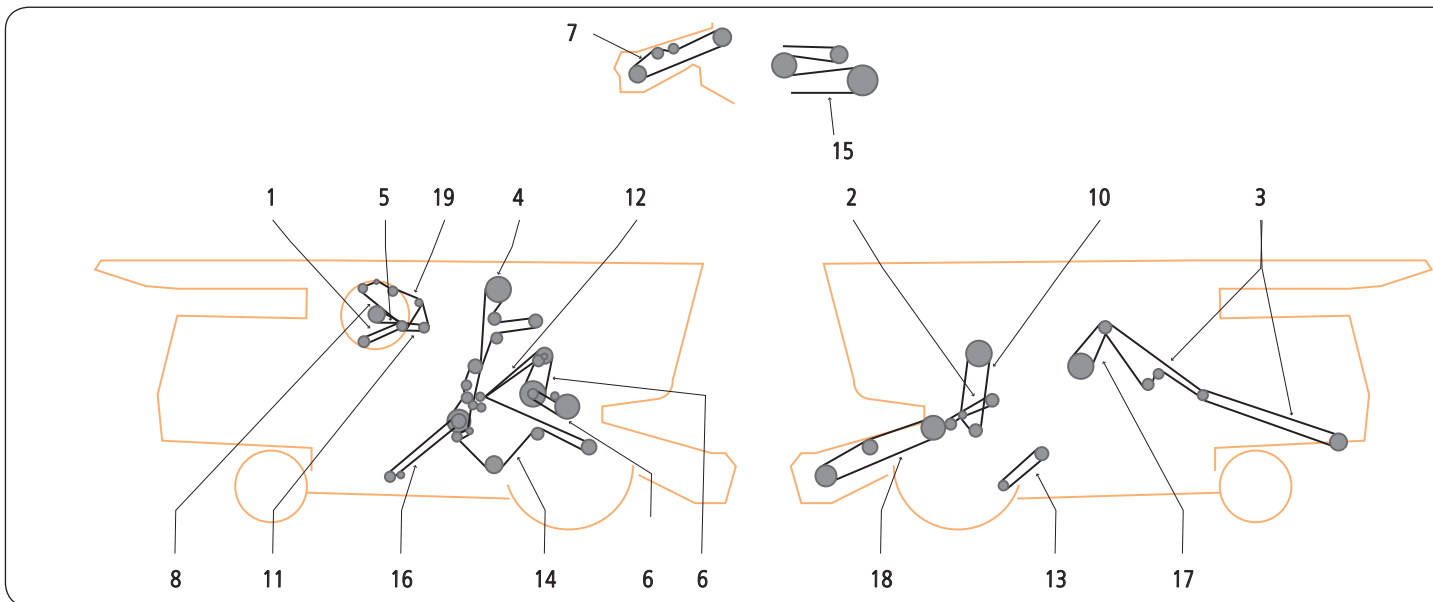

ITEM	APPLICATION	QUANTITY OF V-BELTS IN DRIVE	OE PART NUMBER	COMMENT
1	COOLING FAN	1	H132808	
2	ROTARY SCREEN	1	H143869	X
3	ROTARY SCREEN DRIVE	1	H134216	X
4	AIR CONDITIONING COMPRESSOR	1	H134437	
5	CLEAN GRAIN ELEVATOR	1	H137830	
5	CLEAN GRAIN ELEVATOR	1	H141167	
6	CYLINDER INTERMEDIATE DRIVE	1	H115759	X
6	FOR EXTENDED RANGE	1	H137670	X
7	CYLINDER DRIVE SLOW SPEED	1	H118618	X
7	CYLINDER DRIVE REGULAR DUAL RANGE AND	1	H115881	
8	LOWER TAILINGS AUGER AND ELEVATOR	1	N110085	
9	FOR ALTERNATOR	1	H134344	
10	SECONDARY COUNTERSHAFT	1	H128010	
11	SHOE. STRAW WALKER AND CONVEYOR AUGERS	1	H131169	
12	UNLOADING SYSTEM	1	AH127866	
13	SHORT REAR	1	P47885	
13	LONG REAR	1	H125381	
13	FRONT	1	H125380	
14	REGULAR	1	H140404	
14	SLOW SPEED	1	H137264	X
15	HEADER AND REEL PUMP	1	H125565	
15	HAEDER AND REEL PUMP	1	H140160	
16	VARIABLE SPEED FEEDER HOUSE	1	H125711	X
17	OPTIONAL BEATER (75 PERCENT)	1	AH131960	
17	BEATER (100 PERCENT)	1	AH139436	
18	FIXED SPEED FEEDER HOUSE WITH REVERSER	1	H126345	
19	STRAW SPREADER	1	H128234	

X - not in standard offer

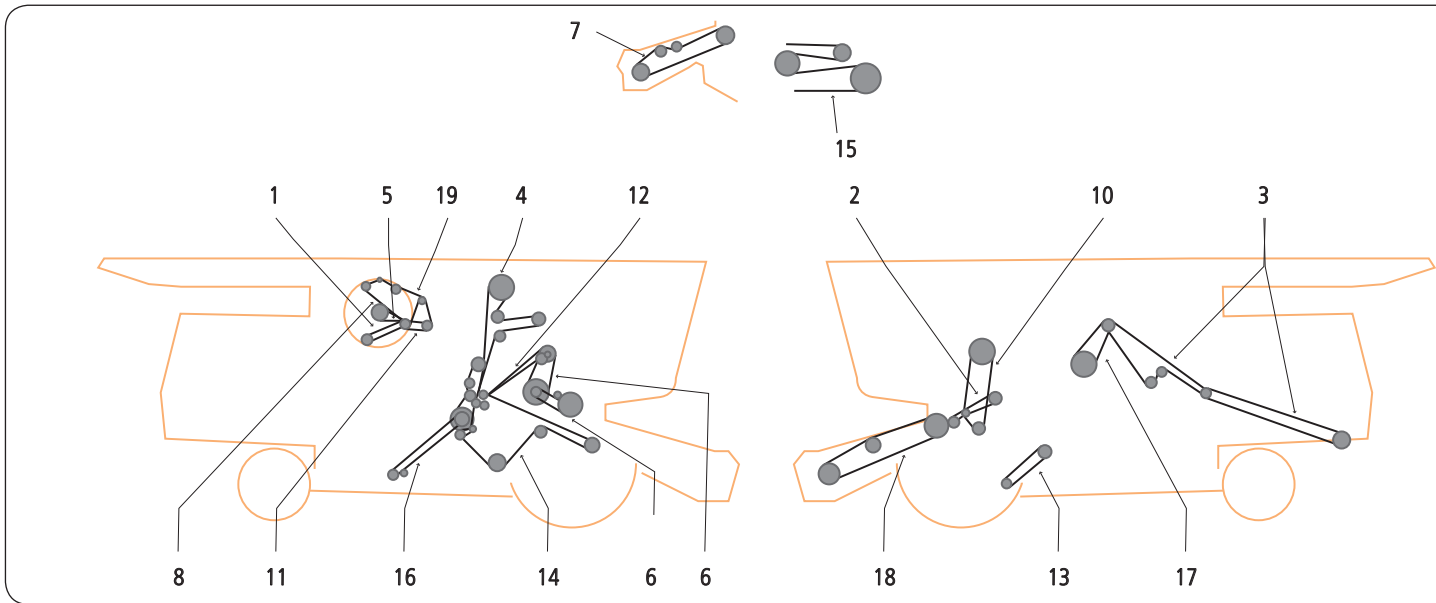

ITEM	APPLICATION	QUANTITY OF V-BELTS IN DRIVE	OE PART NUMBER	COMMENT
1	COOLING FAN	1	H132808	
2	ROTAYR SCREEN	1	H143869	X
3	ROATRY SCREEN DRIVE	1	H133577	X
4	AIR CONDITIONING COMPRESSOR	1	H134437	
5	CLEAN GRAIN ELEVATOR	1	H135458	
5	CLEAN GRAIN ELEVATOR	1	H141166	
6	CYLINDER INTERMEDIATE DRIVE	1	H115759	X
6	FOR EXTENDED RANGE	1	H137670	X
7	CYLINDER DRIVE SLOW SPEED	1	H118618	X
7	CYLINDER DRIVE REGULAR DUAL RANGE AND UNLOADING SYSTEM	1	H115881	
7	UNLOADING SYSTEM	1	AH127866	
8	LOWER TAILINGS AUGER AND ELEVATOR	1	N110085	
9	FOR ALTERNATOR	1	H134344	
10	SECONDARY COUTERSHAFT	1	H128010	
11	SHOE. STRAW WALKER AND CONVEYOR AUGERS	1	H131169	
12	UNLOADING SYSTEM	1	AH127866	
13	SHORT REAR	1	P47885	
13	LONG REAR	1	H125381	
13	FRONT	1	H125380	
14	REGULAR	1	H140404	
14	SLOW SPEED	1	H137264	X
15	HEADER AND REEL PUMP	1	H125565	
15	HEADER AND REEL PUMP	1	H140160	
16	VARIABLE SPEED FEEDER HOUSE	1	H125711	X
17	OPTIONAL BEATER (75 PERCENT)	1	AH131960	
17	BEATER (100 PERCENT)	1	AH139436	
18	FIXED SPEED FEEDER HOUSE WITH REVERSER	1	H126345	
19	STRAW SPREADER	1	H128234	

X - not in standard offer

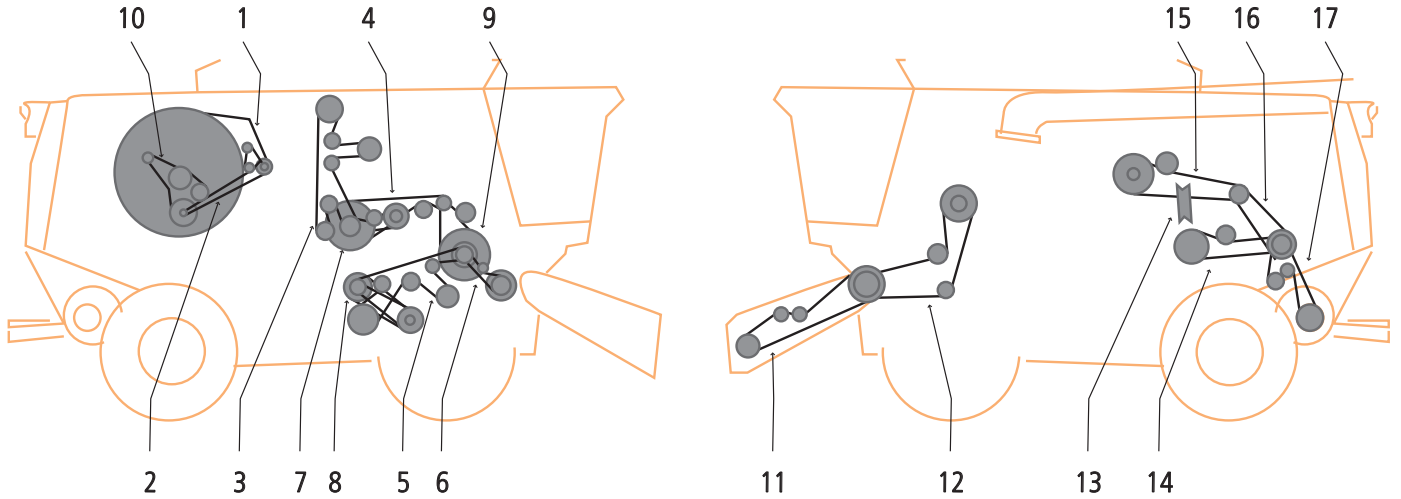

ITEM	APPLICATION	QUANTITY OF V-BELTS IN DRIVE	OE PART NUMBER	COMMENT
1	ROTARY SCREEN DRIVE	1	H206807	X
2	ROTARY SCREEN DRIVE	1	H157104	X
3	GRAIN ELEVATOR	1	H158512	X
4	RH JACKSHAFT (REAR)	1	H154723	X
5	SHOEFAN AND CONVEYOR AUGERS	1	H175587	
6	FEED ACCELERATOR	1	H209606	X
6	FEED ACCELERATOR	1	H216027	X
7	TAILING AUGER AND ELEVATOR	1	H154731	
8	CLEANING FAN	1	H165072	X
9	RH JACKSHAFT	1	AH150678	X
10	ALTERNATOR 95 AMP	1	R135606	X
11	VARIABLE DRIVE FEEDER HOUSE	1	H157732	X
12	HEADER AND REEL PUMP	1	H156541	
13	STS VARIABLE DRIVE	1	H165545	X
14	DISCHARGE BEATER	1	H168301	X
15	UNLOADING AUGER	1	AH160080	X
16	COUNTERSHAFT BEATER CHOPPER	1	H157514	X
17	STRAW CHOPPER	1	H204747	X

X - not in standard offer

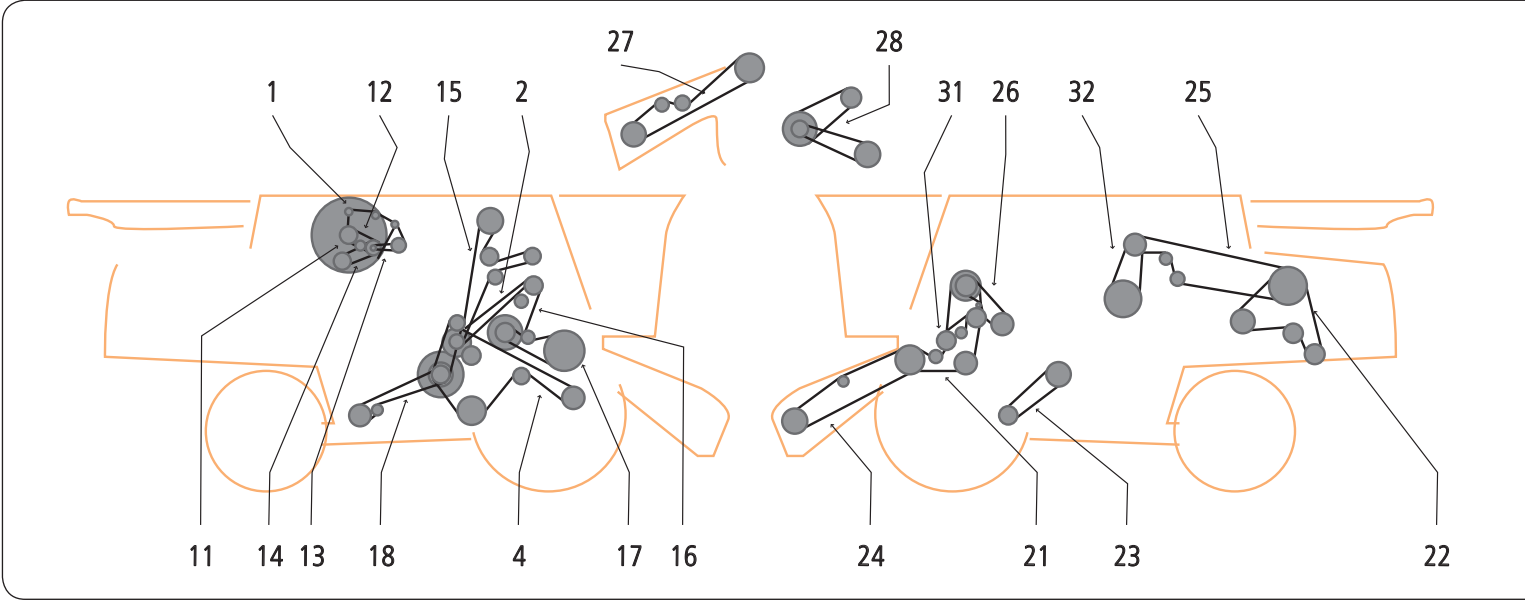

ITEM	APPLICATION	QUANTITY OF V-BELTS IN DRIVE	OE PART NUMBER	COMMENT
1	ALTERNATOR	1	H163515	X
2	SECONDARY COUNTERSHAFT	1	H128010	
4	STRAW WALKER AND CONVEYOR AUGERS	1	H131169	
5	COOLING FAN	1	H161796	X
6		1	H145158	X
7	ROTARY SCREEN DRIVE	1	H160406	
8	AIR CONDITIONING COMPRESSOR	1	H134437	
9	CLEAN GRAIN ELEVATOR	1	H160171	
10	CYLINDER INTERMEDIATE DRIVE	1	H162629	X
11	CYLINDER DRIVE SLOW SPEED	1	H118618	X
11	CYLINDER DRIVE	1	H115881	
12	LOWER TAILINGS AUGER AND ELEVATOR	1	H110085	X
13	STRIPPER BEATER	1	H139963	X
14	UNLOADING SYSTEM	1	AH127866	
15	FRONT END EQUIPMENT	1	H151952	
16	FRONT STRAW CHOPPER	1	H162541	
17	SLOW SPEED (490-980RPM) OPT.	1	H152180	X
17	REGULAR (750-1350RPM) FAN DRIVE	1	H152146	
18	VARIABLE SPEED	1	H161648	X
19	SEPARATOR	1	H141429	X
20	BEATER DRIVE	1	H143700	
21	FIXED SPEED FEEDER HOUSE	1	H126345	
22	STRAW SPREADER	1	E61326	
22		1	P49604	
23	CHAFF SPREADER DRIVE	1	M95728	

X - not in standard offer

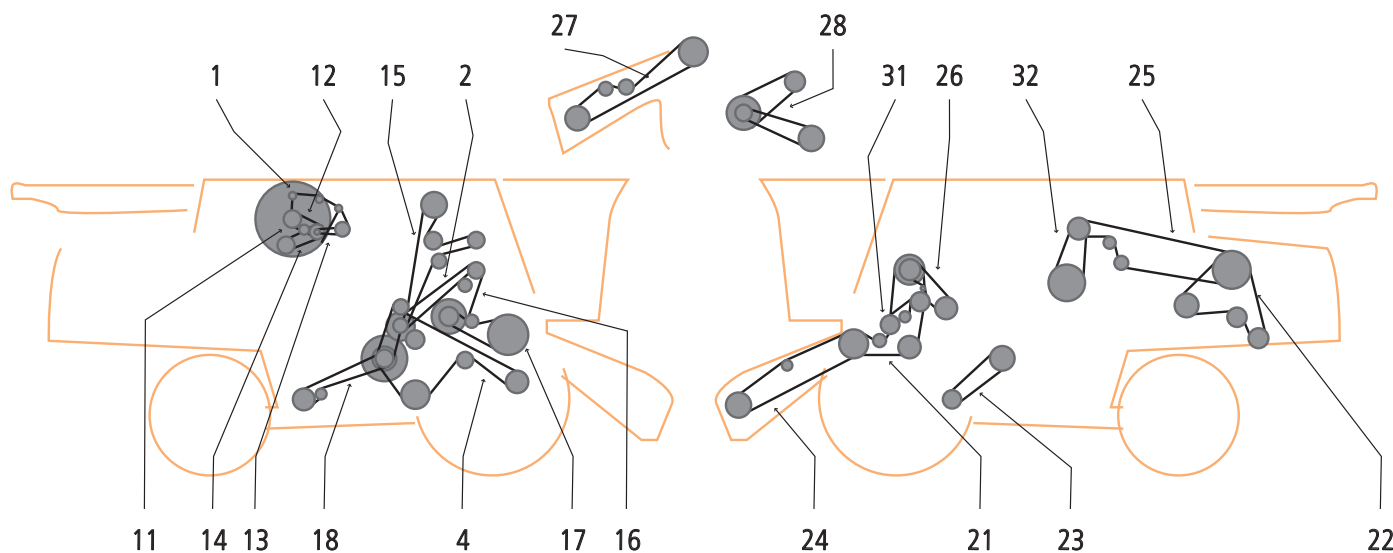

ITEM	APPLICATION	QUANTITY OF V-BELTS IN DRIVE	OE PART NUMBER	COMMENT
1	ALTERNATOR	1	H101813	
2	SECONDARY COUNTERSHAFT	1	H128010	
4	STRAW WALKER AND CONVEYOR AUGERS	1	H131169	
11	COOLING FAN	2	AH140623	X
11	COOLING FAN	1	H153297	
12	COOLING FAN	1	H145158	X
13	ROTARY SCREEN DRIVE	1	H134216	X
13	ROTARY SCREEN DRIVE	1	H146636	X
14	AIR CONDITIONING COMPRESSOR	1	H134437	
15	CLEANING GRAIN ELEVATOR	1	H141167	
16	CYLINDER INTERMEDIATE	1	H115759	X
16	CYLINDER INTERMEDIATE DRIVE	1	H162629	X
17	CYLINDER DRIVE SLOW SPEED	1	H118618	X
17	CYLINDER DRIVE	1	H115881	
18	LOWER TAILINGS AUGER AND ELEVATOR	1	N110085	
21	FRONT END EQUIPMENT	1	H140160	
22	STRAW CHOPPER (FRONT)	1	H141417	X
23	REGULAR (750-1350 RPM) FAN DRIVE	1	H140404	
23	SLOW SPEED (490-980 RPM)	1	H137264	X
24	VARIABLE SPEED	1	H125711	X
25	SEPARATOR	1	H141429	X
26	BEATER DRIVE	1	H143700	
27	FIXED SPEED FEEDER HOUSE	1	H126345	
28	STRAW SPREADER	1	E61326	
28	STRAW SPREADER	1	P49604	
28	CHAFF SPREADER DRIVE	1	M95728	
31	STRIPPER BEATER	1	H139963	X
32	UNLOADING SYSTEM	1	AH127866	

X - not in standard offer

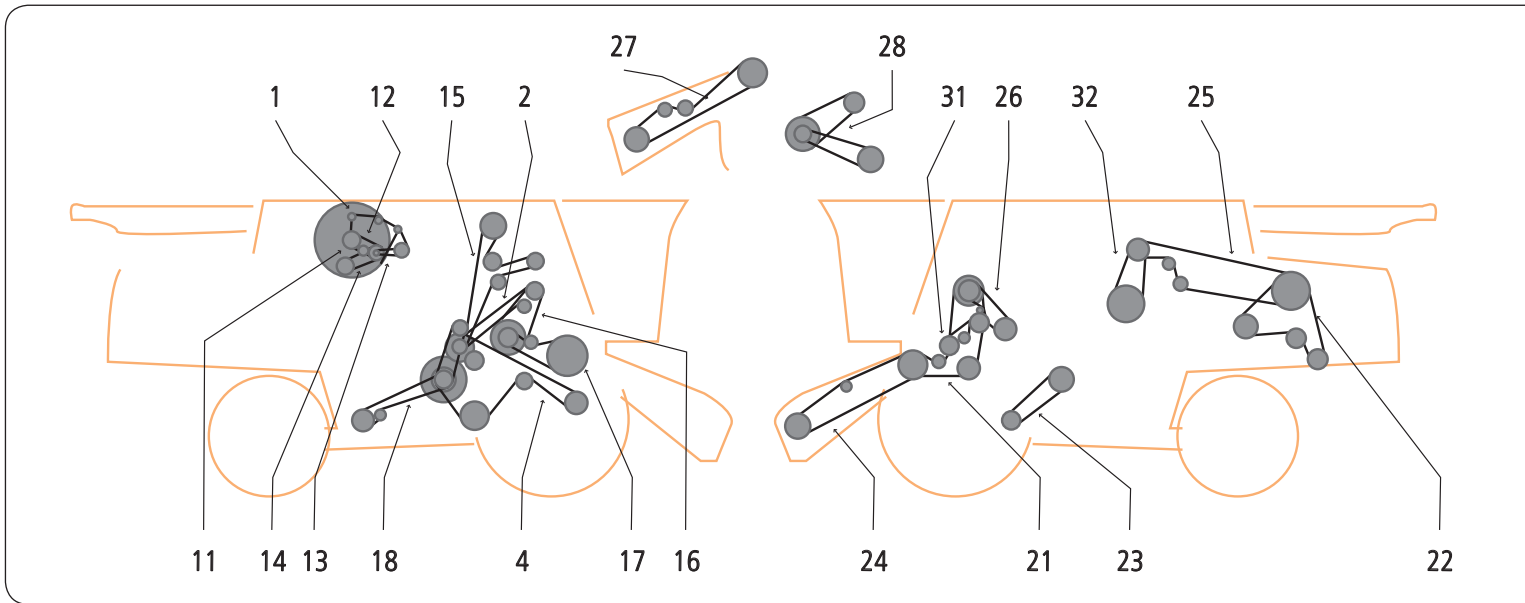

ITEM	APPLICATION	QUANTITY OF V-BELTS IN DRIVE	OE PART NUMBER	COMMENT
1	ALTERNATOR	1	H101813	
2	SECONDARY COUNTERSHAFT	1	H128010	
4	STRAW WALKER AND CONVEYOR AUGERS	1	H131169	
11	COOLING FAN	2	AH140623	X
11	COOLING FAN	1	H153297	
12	COOLING FAN	1	H145158	X
13	ROTARY SCREEN DRIVE	1	H134216	X
13	ROTARY SCREEN DRIVE	1	H146636	X
14	AIR CONDITIONING COMPRESSOR	1	H134437	
15	CLEANING GRAIN ELEVATOR	1	H141167	
16	CYLINDER INTERMEDIATE	1	H115759	X
16	CYLINDER INTERMEDIATE DRIVE	1	H162629	X
17	CYLINDER DRIVE SLOW SPEED	1	H118618	X
17	CYLINDER DRIVE	1	H115881	
18	LOWER TAILINGS AUGER AND ELEVATOR	1	N110085	
21	FRONT END EQUIPMENT	1	H140160	
22	STRAW CHOPPER (FRONT)	1	H141417	X
23	REGULAR (750-1350 RPM) FAN DRIVE	1	H140404	
23	SLOW SPEED (490-980 RPM)	1	H137264	X
24	VARIABLE SPEED	1	H125711	X
25	SEPARATOR	1	H141429	X
26	BEATER DRIVE	1	H143700	
27	FIXED SPEED FEEDER HOUSE	1	H126345	
28	STRAW SPREADER	1	E61326	
28	STRAW SPREADER	1	P49604	
29	CHAFF SPREADER DRIVE	1	M95728	
31	STRIPPER BEATER	1	H139963	X
32	UNLOADING SYSTEM	1	AH127866	

X - not in standard offer

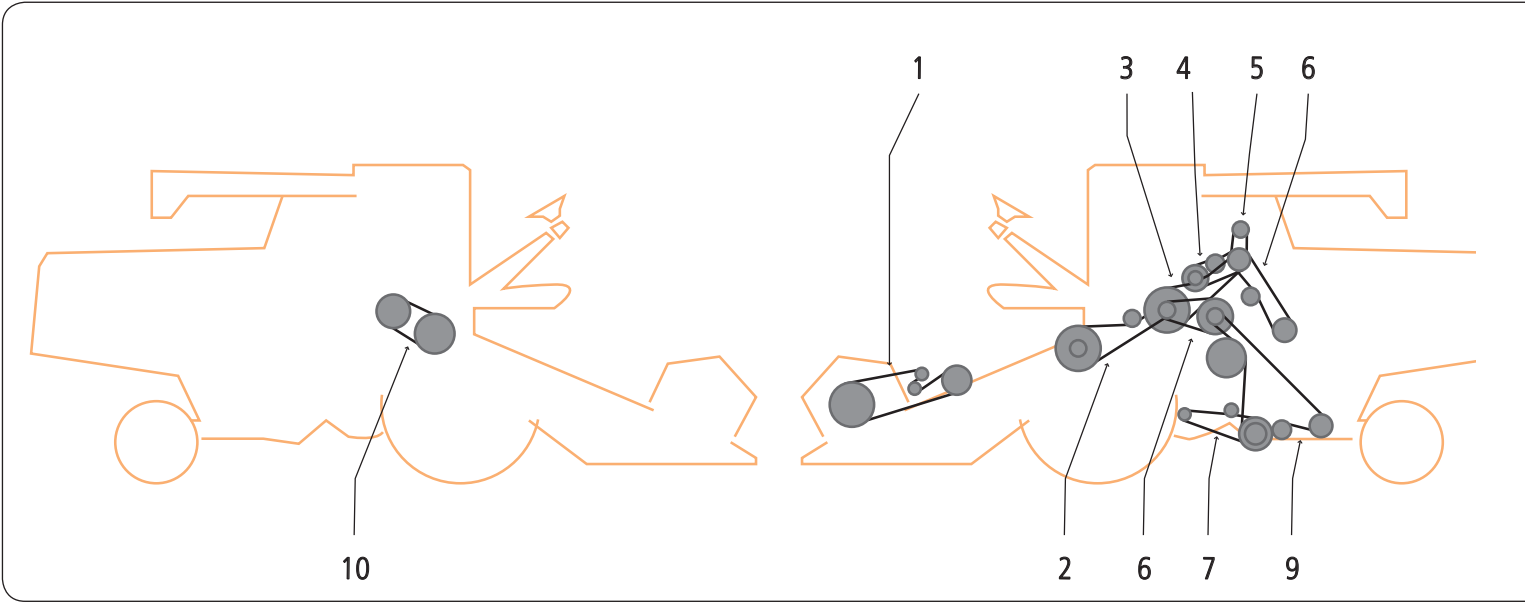

ITEM	APPLICATION	QUANTITY OF V-BELTS IN DRIVE	OE PART NUMBER	COMMENT
1	REEL DRIVE	1	340433458	
2	UPPER SHAFT ELEVATOR	1	340433428	
3	THRESHING DRIVE	1	344 311220	
4	PUMP DRIVE	1	340432232	
5	AUGER DRIVE	1	340433252	
6	HYDRAULIC PUMP	1	344310222	
7	STRAW WALKER - AUGER DRIVE	1	340433968	
8	RETURN DRIVE	1	340433412	
9	FAN DRIVE	1	340433290	
10	CYLINDER VARI-DRIVE	1	340435138	X

X - not in standard offer

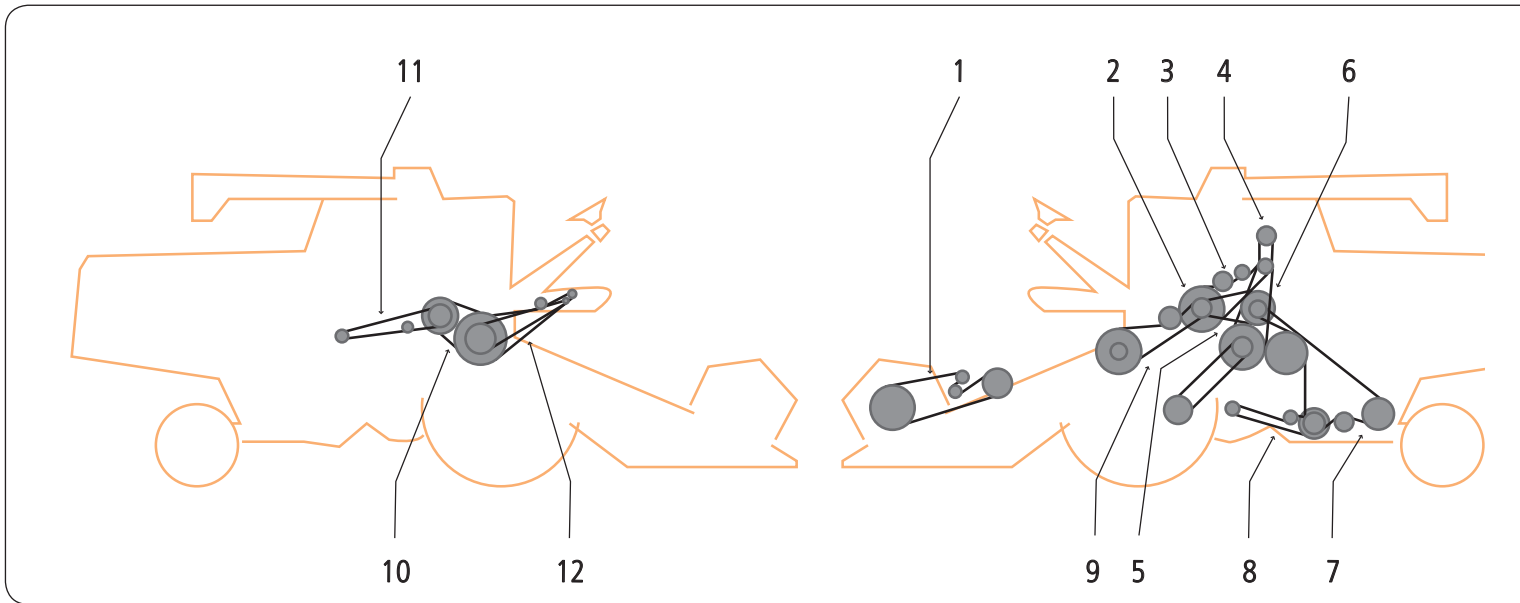

ITEM	APPLICATION	QUANTITY OF V-BELTS IN DRIVE	OE PART NUMBER	COMMENT
1	REEL DRIVE	1	340433458	
2	THRESHING DRIVE	1	344311217	
3	RETURN AUGER DRIVE	1	340433252	
4		1	340433239	
5		1	344311212	
6	RETURN DRIVE	1	340433412	
7	STRAW WALKER - AUGER DRIVE	1	340433970	
8	MAIN FAN	1	340433283	
9	UPPER SHAFT ELEVATOR	1	340433432	
10	CYLINDER VARI-DRIVE	1	340435138	X
11	FAN VARI-DRIVE	1	340433176	
12	BLOWER DRIVE	1	340433188	

X - not in standard offer

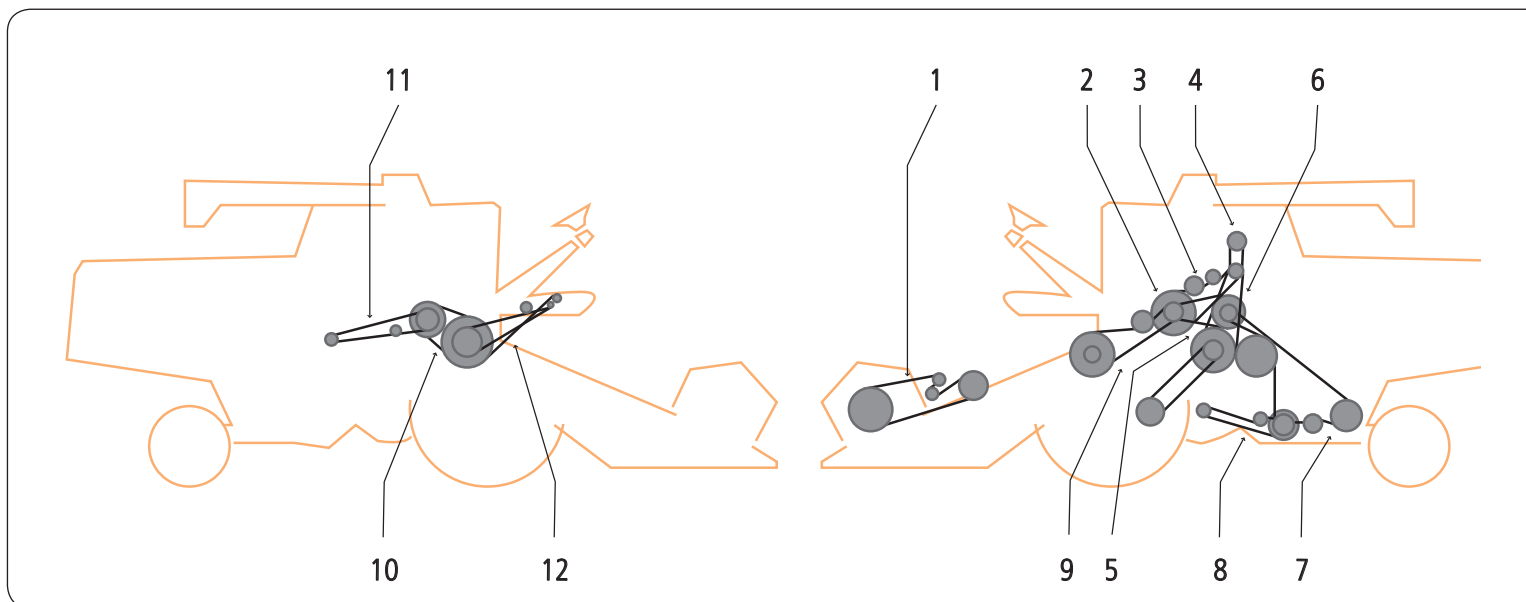

ITEM	APPLICATION	QUANTITY OF V-BELTS IN DRIVE	OE PART NUMBER	COMMENT
1	REEL DRIVE	1	340433458	
2	THRESHING DRIVE	1	344311217	
3	UNLOADING SYSTEM - VIBRATOR	1	340433980	
3	CLEAN GRAIN ELEVATOR. U-JOINT LOADING AUGER	1	E60212	
3	CLEAN GRAIN ELEVATOR	1	H87648	
4	PUMP DRIVE	1	340433223	
4	CLEAN GRAIN ELEVATOR COUNTERSHAFT	1	H23817	
5	TRACTION VARI-DRIVE	1	340435120	X
6	RETURN DRIVE	1	340433412	
6	CLEANING FAN	1	H80726	
7	COMPRESSOR. AC	1	H86273	
7	COMPRESSOR. AC	1	H81742	
7	COMPRESSOR. AC 292	1	H80896	
7	STRAW WALKER - AUGER DRIVE	1	340433970	
7	COMPRESSOR. AC	1	H63772	
8	MAIN FAN	1	340433283	
9	CYLINDER	1	AH80500	
9	UPPER SHAFT ELEVATOR	1	340433432	
10	ENGINE FAN	1	H79236	
10	ENGINE FAN. CAB WITH AIR CONDITIONING	1	H86271	
10	CYLINDER VARI-DRIVE	1	340435138	X
11	ENGINE FAN COUNTERSHAFT	1	H79235	
11	FAN VARI-DRIVE	1	340433176	
12	BLOWER DRIVE	1	340433188	
12	FRONT STRAW CHOPPER	1	H20407	

X - not in standard offer

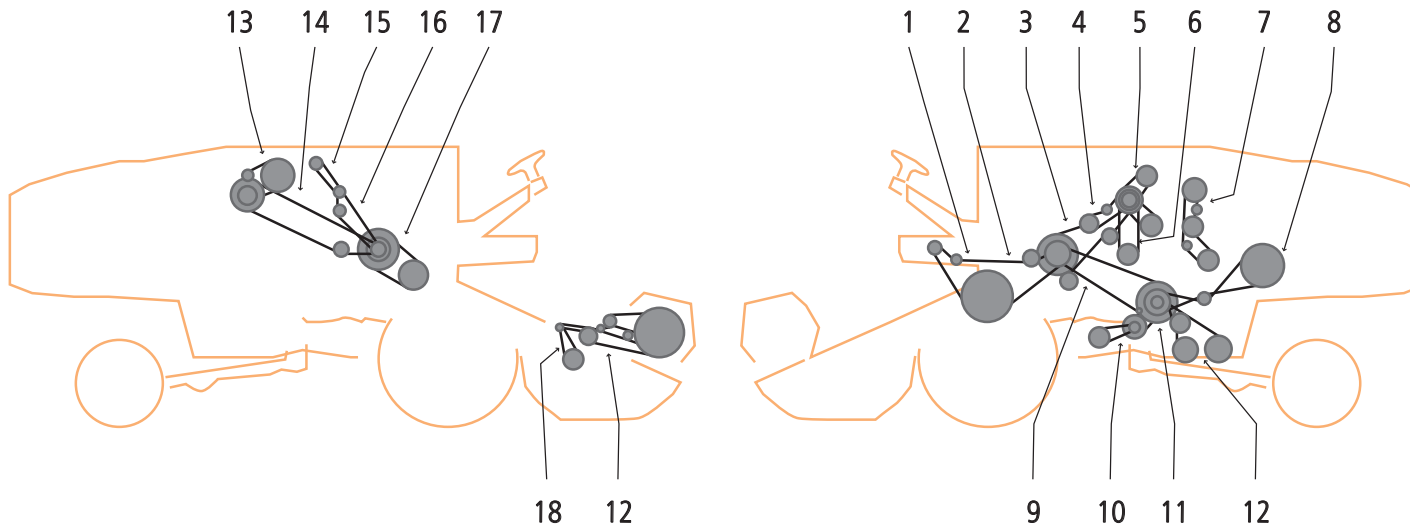

ITEM	APPLICATION	QUANTITY OF V-BELTS IN DRIVE	OE PART NUMBER	COMMENT
1	BLOWER	1	340433182	
2	ELEVATOR	1	340433531	
3	THRESHING DRIVE	1	344311221	
4	AUGER DRIVE	1	340433417	
5	HYDRAULIC PUMP	1	340432244	
6	HYDRAULIC PUMP	1	344311212	
7	GRAIN ELEVATOR	1	340433289	
8	STRAW WALKER	1	340433455	
9	MAIN RETURN DRIVE	1	340433537	
10	MAIN FAN (SECONDARY)	1	340433410	
11	MAIN FAN (PRIMARY)	1	340433409	
12	GRAIN TAILINGS AUGER	1	340433430	
13		1	340433236	
14		1	340433456	
15	ROTARY FILTER (SECONDARY)	1	340433134	
16	ROTARY FILTER (PRIMARY)	1	340433162	
17	FEEDING SHAFT	1	340435146	
18	REEL VARI-DRIVE	1	340434140	X
19	REEL DRIVE	1	340433456	

X - not in standard offer

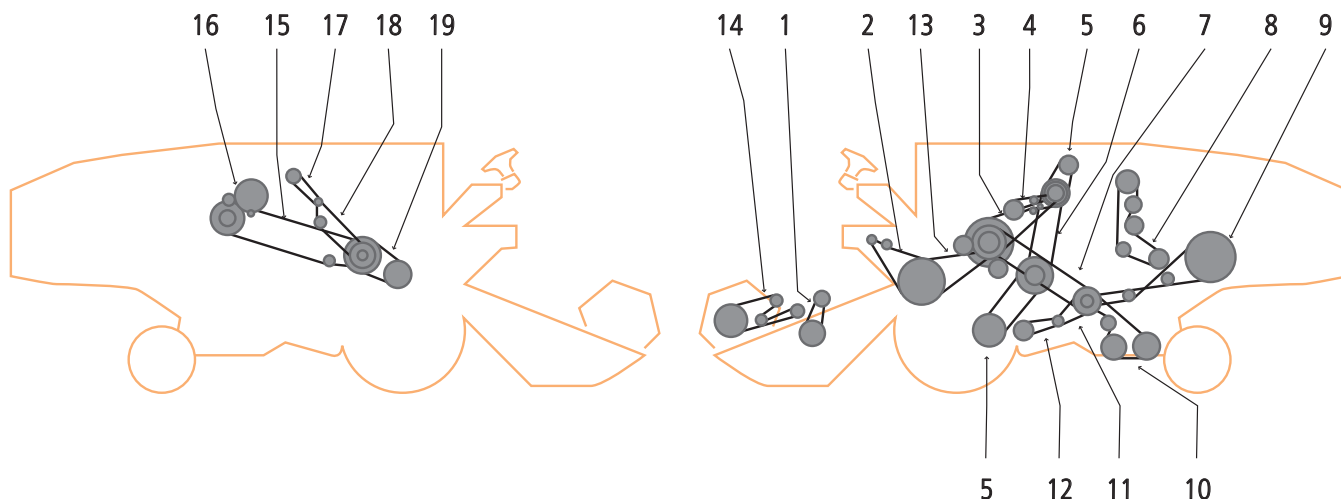

ITEM	APPLICATION	QUANTITY OF V-BELTS IN DRIVE	OE PART NUMBER	COMMENT
1	REEL VARI-DRIVE (1978)	1	340434138	
1	REEL VARI-DRIVE	1	340434140	X
2	BLOWER DRIVE	1	340433182	
3	CYLINDER VARI-DRIVE	1	344311221	
3	CONVERTER	1	340433418	
4	THRESHING DRIVE	1	344311222	
4	AUGER DRIVE	1	340433417	
6	OIL PUMP	1	340432243	
6	HYDRAULIC PUMP	1	340433244	
7	RETURN DRIVE	1	340433537	
8	FAN	1	340433289	
9	STRAW WALKER	1	340433455	
10	TAILINGS AUGER DRIVE	1	340433430	
11	FAN VARI-DRIVE	1	340433409	
12	MAIN FAN	1	340433410	
13		1	340433531	
14	REEL DRIVE (1978)	1	340433316	
14	REEL DRIVE	1	340433435	
15		1	340433456	
16		1	340433236	
17	ROTARY FILTER	1	340433134	
18	FILTER	1	340433162	

X - not in standard offer

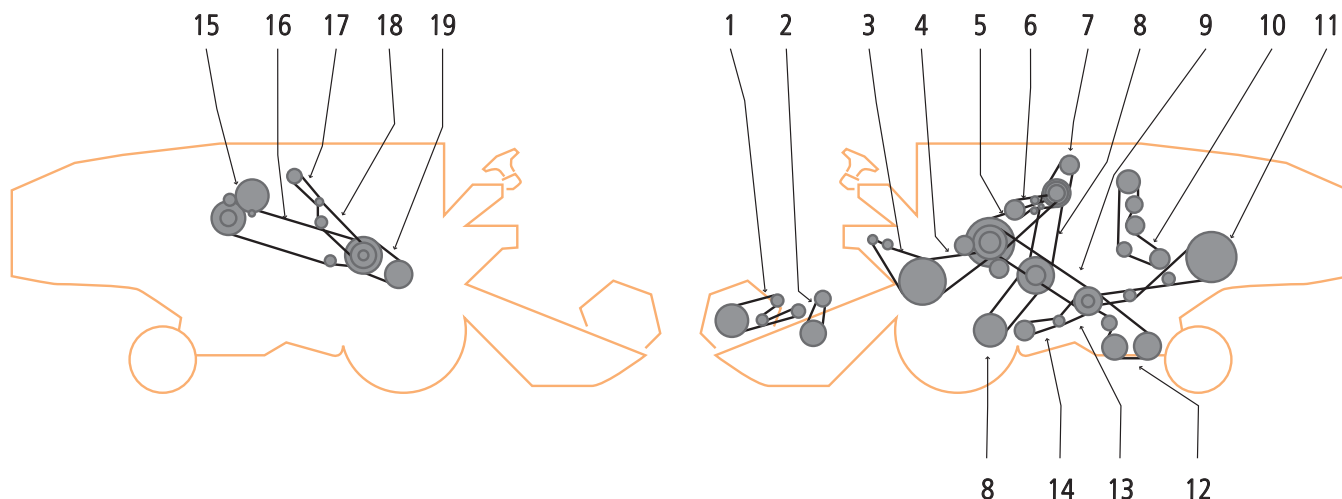

ITEM	APPLICATION	QUANTITY OF V-BELTS IN DRIVE	OE PART NUMBER	COMMENT
1	REEL DRIVE (1978) REEL DRIVE	1	340433316	
1	REEL DRIVE	1	340433435	
2	REEL VARI-DRIVE	1	340434138	
2	REEL VARI-DRIVE	1	340434140	X
3	BLOWER	1	340433182	
4		1	340433531	
5	THRESHING DRIVE	1	344311221	
5	THRESHING DRIVE (1978)	1	344311316	
6	AUGER DRIVE	1	340433417	
7	HYDRAULIC PUMP	1	340432243	
7	HYDRAULIC PUMP	1	340432244	
9	MAIN RETURN DRIVE	1	340433537	
10	FAN	1	340433289	
11	STRAW WALKER	1	340433455	
12	GRAIN TAILINGS AUGER	1	340433430	
13	MAIN FAN (PRIMARY)	1	340433409	
14	MAIN FAN (SECONDARY)	1	340433410	
14	CONVERTER	1	340433418	
15	FEEDING SHAFT	1	340433236	
16		1	340433456	
17	ROTARY FILTER (SECONDARY)	1	340433134	
18	ROTARY FILTER (PRIMARY)	1	340433162	
19	CYLINDER DRIVE	1	344351146	

X - not in standard offer

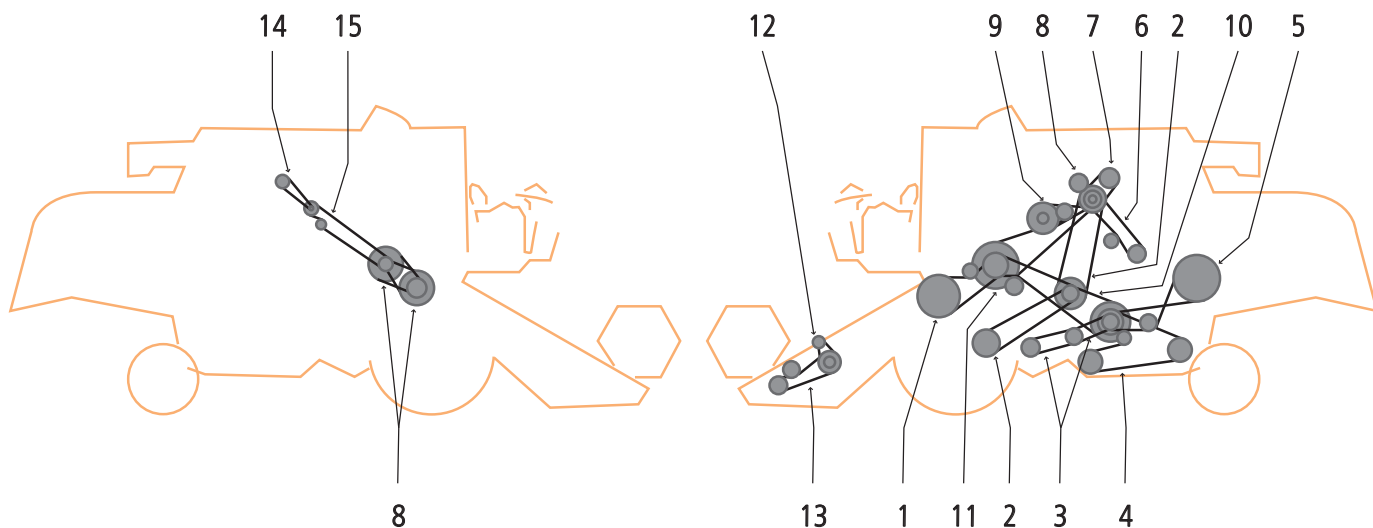

ITEM	APPLICATION	QUANTITY OF V-BELTS IN DRIVE	OE PART NUMBER	COMMENT
1		1	344311127	
3	MAIN FAN	1	340433424	
4	GRAIN TAILINGS AUGER	1	344311134	
5	STRAW WALKER	1	340433458	
6	HYDRAULIC PUMP	1	344311217	
7	OIL PUMP	1	340432243	
8	COMPRESSOR DRIVE	1	340433129	
9	AUGER DRIVE	1	340433467	
10	RETURN DRIVE	1	340433540	
11	CYLINDER VARI-DRIVE	1	344311318	
12	REEL VARI-DRIVE	1	340434138	
13	CONVERTER	1	340433418	
14	ROTARY FILTER (SECONDARY)	1	340433144	
15	ROTARY FILTER (PRIMARY)	1	340433184	

X - not in standard offer

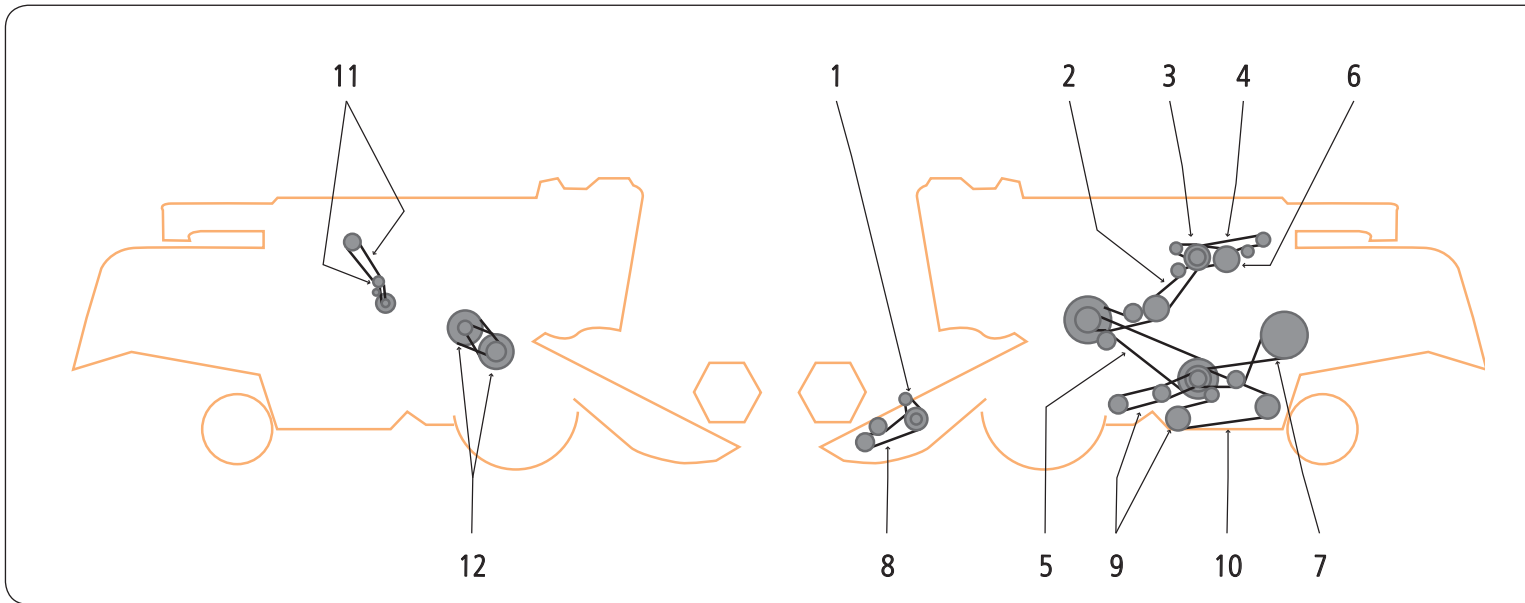

ITEM	APPLICATION	QUANTITY OF V-BELTS IN DRIVE	OE PART NUMBER	COMMENT
1	REEL VARI-DRIVE	1	340434138	
2	CYLINDER DRIVE	1	344311418	
3	COMPRESSOR	1	340433038	
4	HYDRAULIC PUMP	1	344311314	
5	RETURN DRIVE	1	340433540	
6	OIL PUMP	1	340433256	
7	STRAW WALKER	1	340433457	
8	CONVERTER DRIVE	1	340433418	
9	MAIN FAN	1	340433424	
10	GRAIN TAILINGS AUGER	1	344311134	
11	ROTARY FILTER	1	340433143	

X - not in standard offer

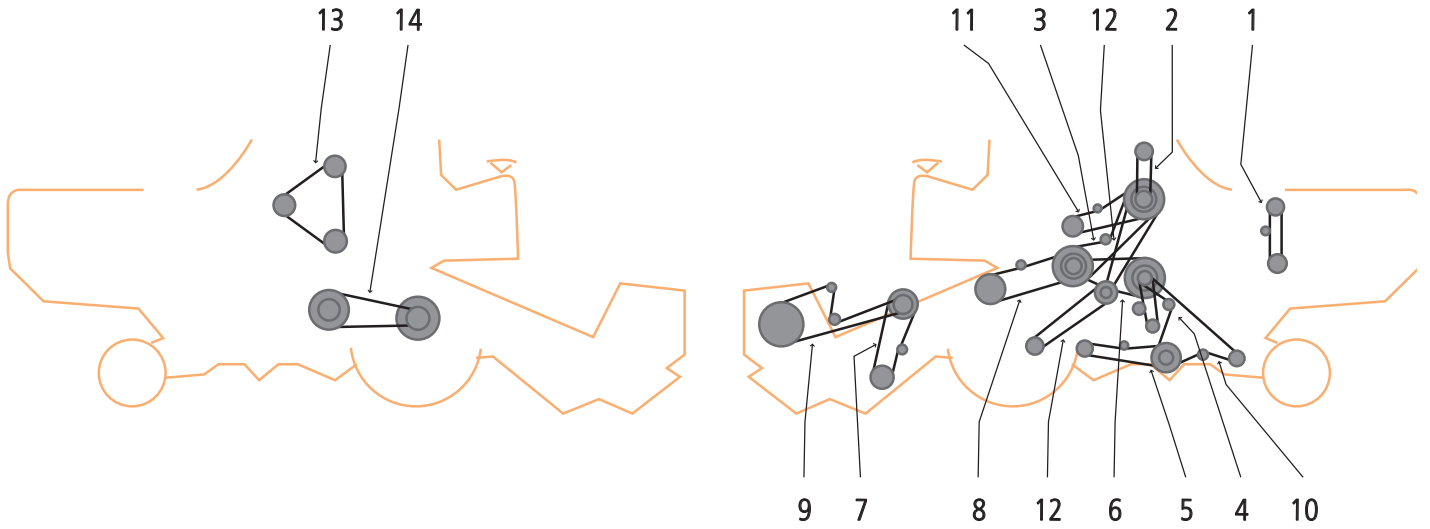

ITEM	APPLICATION	QUANTITY OF V-BELTS IN DRIVE	OE PART NUMBER	COMMENT
1	FAN DRIVE GRAIN	1	340433131	
2	PUMP	1	340433223	
3	AUGER DRIVE	1	340433266	
4	GRAIN ELEVATOR	1	340433274	
4	GRAIN ELEVATOR	1	340433284	
5	FAN	1	340433281	
6	RETURN DRIVE	1	340433414	
7	RETURN DRIVE (RICE)	1	340433414	
7	RETURN DRIVE	1	340433419	
8	FEED CHANNEL	1	340433427	
9	REEL (RICE)	1	340433440	
9	REEL	1	340433441	
10	STRAW WALKER	1	340433970	
11	THRESHING DRIVE	1	344311218	
12	TRACTION DRIVE	1	340435120	X
12	TRACTION DRIVE	1	340433145	
12	BLOWER DRIVE	1	340433185	
13	FAN	1	340433271	
14	CYLINDER VARI-DRIVE	1	340435135	X
14	CYLINDER VARI-DRIVE (RICE)	1	340435138	X

X - not in standard offer

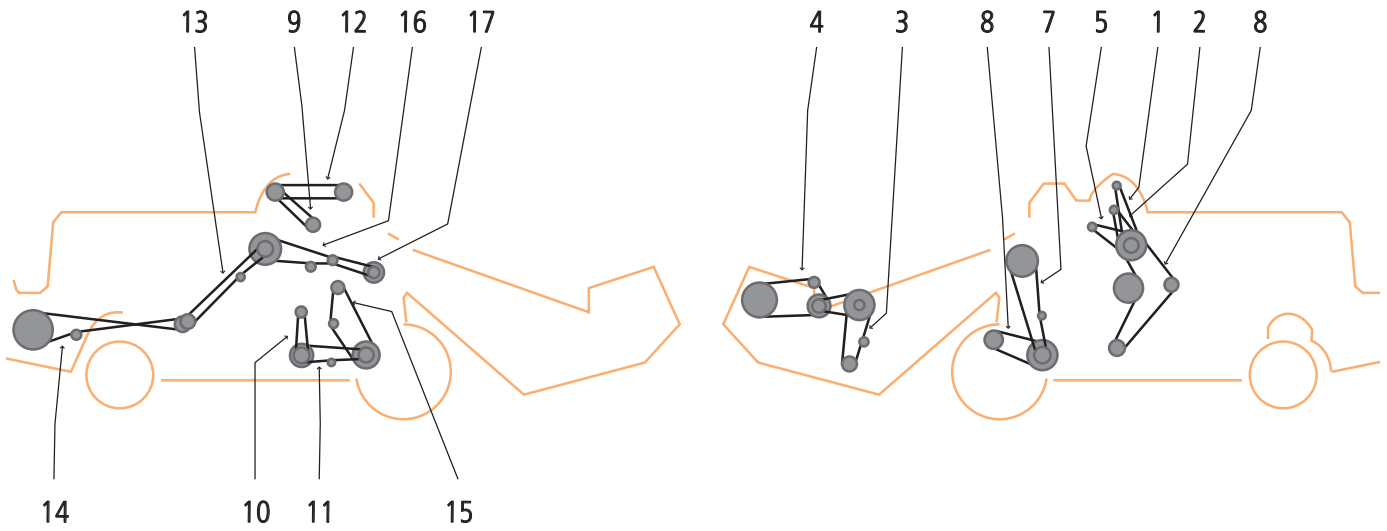

ITEM	APPLICATION	QUANTITY OF V-BELTS IN DRIVE	OE PART NUMBER	COMMENT
1	FRN VARI-DRIVE	1	340433163	
2	FAN VARI-DRIVE	1	340433176	
3	RETURNED	1	340433415	
4	REEL	1	340433433	
5	DE-AWNER	1	340433425	
6	STRAW WALKER	1	340433968	
7	THRESHING DRIVE	1	340434247	
8	TRACTION DRIVE	1	340435100	X
9	GRAIN TRACTION DRIVE	1	340433241	
10	GRAIN UNLOADING	1	340433233	
11	RETURN DRIVE	1	340433926	
12	GRAIN ELEVATOR	1	340433272	
13		1	340433441	
14		1	340433453	
15	FAN	1	340433281	
16	CYLINDER DRIVE	1	340433961	
17	DE-AWNER	1	340435100	X

X - not in standard offer

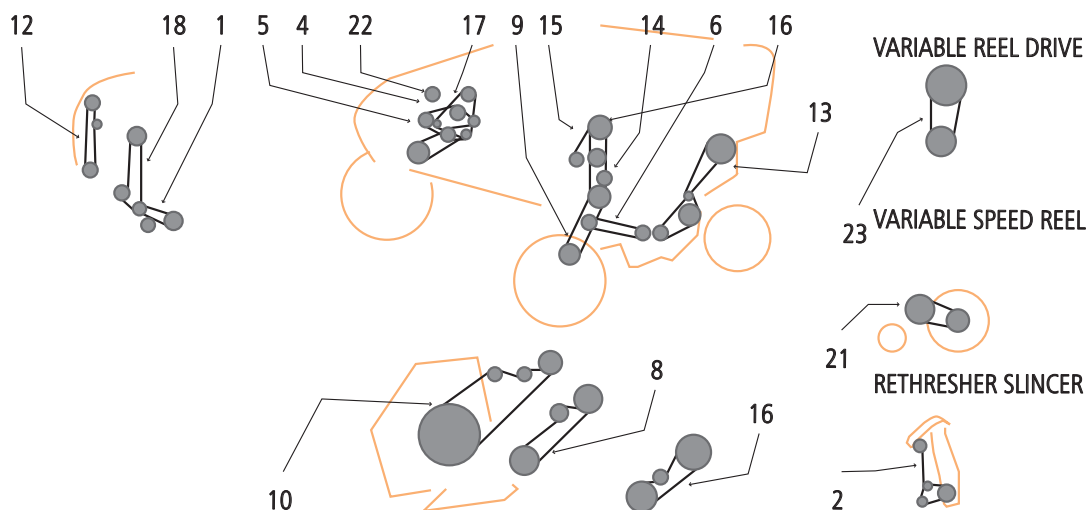

ITEM	APPLICATION	QUANTITY OF V-BELTS IN DRIVE	OE PART NUMBER	COMMENT
1	FANNING MILL	1	784797M2	
2	TANK UNLOADER	1	228813M1	
3	FANNING MILL UPPER	1	1855008M1	
5	HYDRAULIC PUMP	1	230381M1	
6	GENERATOR	1	893575M1	X
7	DRIVE	1	793863M1	X
8	MAIN BELT	1	793862M1	X
9	MULTI FLOW	1		
10	RETURNS	1	795514M4	
10	RETURNS	1	795582M2	
11	SHAKER	1	1615254M1	
12	GRAIN ELEVATOR	1	784796M2	
15	REDUCER	1	603719M1	
16	KNIFE	1	785585M3	
17	REEL	1	1615254M1	
17	REEL	1	1615333M1	

X - not in standard offer

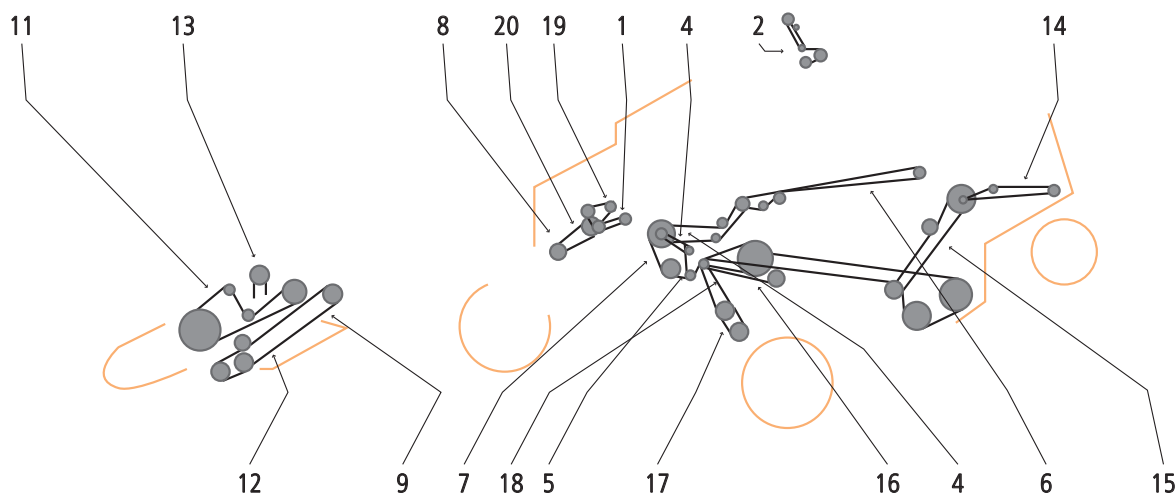

ITEM	APPLICATION	QUANTITY OF V-BELTS IN DRIVE	OE PART NUMBER	COMMENT
0	PICK UP	1	1047702M1	
1	AIR CONDITIONING	1	843045M1	
2	AUXILIARY CYLINDER (SLINGER)	1	834332M1	
3	CHOPPER DRIVE. HIGH SPEED	1	843760M1	
3	CHOPPER DRIVE. LOW SPEED	1	843759M1	
4	CLEANING FAN	1	832877M1	
5	CLEANING FAN. COUNTERSHAFT	1	228997M1	X
6	COUNTERSHAFT DRIVE	1	843758M1	
7	CYLINDER	1	832873M1	X
8	AIR INTAKE	1	240575M2	
9	KNIFE WOBBLE. 13 RIGID BAR HIGH SPEED	1	832085M1	
9	KNIFE WOBBLE. FLOATING CUT BAR	1	833962M1	
9	KNIFE WOBBLE. RIGID CUT BAR	1	834190M1	
9	KNIFE WOBBLE. SPEED UP 15.16.18.20	1	843029M1	X
10	REAR BEATER OR STRAW CHOPPER	1	843747M1	
11	REEL	1	834140M1	
12	REEL COUNTERSHAFT	1	834139M1	
13	REEL. VARIABLE SPEED	1	833768M1	
14	STRAW SPREADER	1	843742M1	
15	STRAW WALKER	1	832867M1	X
16	TANK UNLOADER	1	832878M1	
17	TRACTION. DRIVE LOWER	1	843732M2	X
18	TRACTION. DRIVE UPPER	1	832790M3	X
18	TRACTION. DRIVE UPPER	1	844091M1	X
19	WATER PUMP. FAN. ALTERNATOR	1	532779M92	
19	WATER PUMP. FAN. ALTERNATOR	1	844171M1	X
20	HYDRAULIC PUMP	1	230380M1	

X - not in standard offer

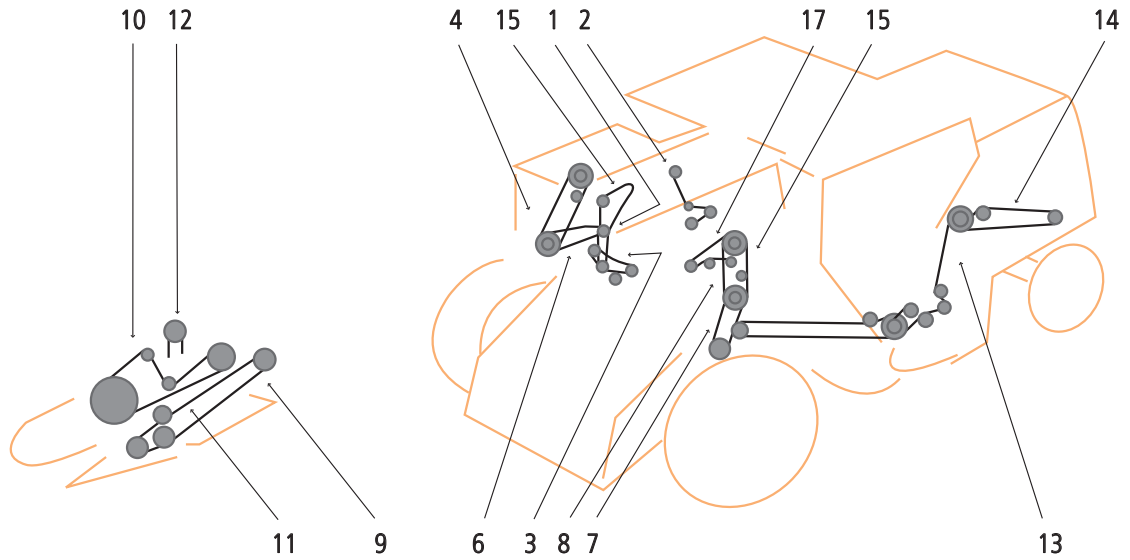

ITEM	APPLICATION	QUANTITY OF V-BELTS IN DRIVE	OE PART NUMBER	COMMENT
0	PICK-UP	1	1047702M1	
0	CHOPPER DRIVE	1	1051235M1	
0	STRAW CHOPPER CORN KIT. LOW SPEED	1	842935M1	
1	CLEANING FAN COUNTERSHAFT	1	227457M1	
2	AUXILIARY CYLINDER (SLINGER)	1	834332M1	
3	CLEANING FAN	1	227976M1	
3	CLEANING FAN. HIGH SPEED	1	834492M2	
5	GRAIN AUGER	1	227984M1	
6	HYDRAULIC PUMP	1	843737M1	
7	TRACTION LOWER. 4 SPEED	1	230097M2	
7	HYDROSTATIC. LOWER	1	834176M1	
8	HYDROSTATIC. UPPER	1	834175M1	
9	KNIFE WOBBLE. CENTERED CHAIN DRIVE	1	834058M1	
9	KNIFE WOBBLE. RIGID CUT BAR	1	195671M1	
9	KNIFE WOBBLE. FLOATING CUT BAR	1	833962M1	
9	KNIFE WOBBLE. RIGID CUT BAR	1	834190M1	
10	REEL	1	834140M1	
11	REEL COUNTERSHAFT	1	834139M1	
12	REEL. VARIABLE SPEED	1	833768M1	
13	RETURN AUGER AND WALKER	1	227986M2	
14	STRAW SPREADER (DUAL)	1	834254M1	
15	TANK UNLOADER	1	228813M3	
16	WATER PUMP. FAN AND ALTERNATOR	1	268847M91	
16	WATER PUMP. FAN AND ALTERNATOR	1	532779M92	
17	MAIN DRIVE	1	230556M4	X

X - not in standard offer

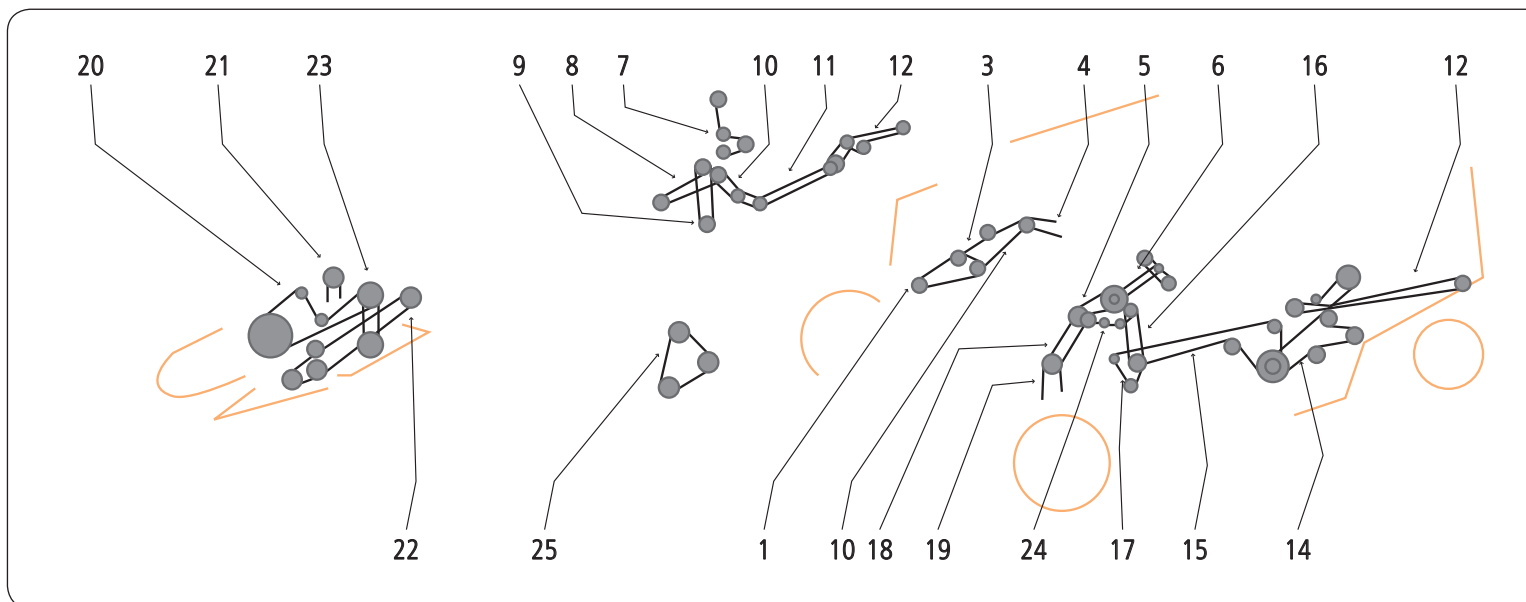

ITEM	APPLICATION	QUANTITY OF V-BELTS IN DRIVE	OE PART NUMBER	COMMENT
1	HYDRAULIC PUMP (S/N 00511 - 2474)	1	222882M2	
1	HYDRAULIC PUMP (S/N >2474)	1	842413M1	
1	RADIATOR FAN	1	833870M1	
1	HYDRAULIC PUMP (S/N < 511)	1	842464M2	
2	RADIATOR FAN	1	259047M91	
2	RADIATOR FAN	1	833869M1	
3	ALTERNATOR	1	1687531M1	
3	ALTERNATOR	1	844079M1	
4	AIR CONDITIONING	1	1686883M1	
4	AIR CONDITIONING (S/N 511 - 5829)	1	834492M1	
4	AIR CONDITIONING (S/N < 511)	1	842463M1	
4	AIR CONDITIONING (S/N 5829 - 7663)	1	843045M1	
5	MAIN DRIVE	1	833865M1	
6	AIR INTAKE	1	833867M1	
7	RETURNS ELEVATOR	1	833854M1	
9	REEL	1	842845M1	
10	STRAW CHOPPER (S/N < 9413)	1	833871M1	
10	STRAW CHOPPER (S/N > 9413)	1	843948M1	X
11	STRAW CHOPPER (S/N < 9413)	1	832866M2	
11	STRAW CHOPPER (S/N > 9413)	1	843747M1	
12	STRAW CHOPPER DRIVE	1	843760M1	
12	STRAW CHOPPER DRIVE (S/N > 9413)	1	832906M1	
12	STRAW CHOPPER DRIVE (S/N < 9413)	1	833872M1	
13	STRAW SPREADER	1	842110M1	
14	STRAW WALKER	1	833860M1	
15	SHAKER SHOE	1	273757M91	
16	SHAKER SHOE - COUNTERSHAFT - FAN (S/N < 9413)	1	274015M91	
16	SHAKER SHOE - COUNTERSHAFT - FAN (S/N > 9413)	1	281560M91	
17	CLEANING FAN	1	833863M1	X
17	CLEANING FAN, SMALL SEED KIT	1	842423M1	X
18	TRACTION UPPER, 4 SPEED	1	833858M4	X
18	TRACTION UPPER, HYDRO	1	833866M1	X
19	TRACTION LOWER, 4 SPEED	1	833858M4	X
19	TRACTION LOWER, HYDRO	1	833866M1	X
20	REEL	1	834140M1	
21	REEL VARIABLE SPEED	1	833768M1	
22	KNIFE DRIVE, RIDIG CUT BAR 13 FT.	1	834058M1	
22	WOBBLE BOX, WITH 30 FT. TABLE	1	210774M1	X
22	KNIFE WOBBLE, RIDIG CUT BAR WITH SPEED UP KIT	1	832085M1	
22	KNIFE WOBBLE, FLOATING CUT BAR	1	833962M1	

ITEM	APPLICATION	QUANTITY OF V-BELTS IN DRIVE	OE PART NUMBER	COMMENT
22	KNIFE WOBBLE RIDIG CUT BAR, 15 FT. - 24 FT.	1	834190M1	
22	WOBBLE BOX, WITH DRAPER TABLE	1	842809M1	
23	REEL COUNTERSHAFT	1	834139M1	
24	GRAIN TANK UNLOADER	1	833862M3	
24	ALTERNATOR, V8 ENGINE (S/N > 13173)	1	3040950M91	
25	ALTERNATOR, V8 ENGINE (S/N < 13173)	1	844163M1	X

X - not in standard offer

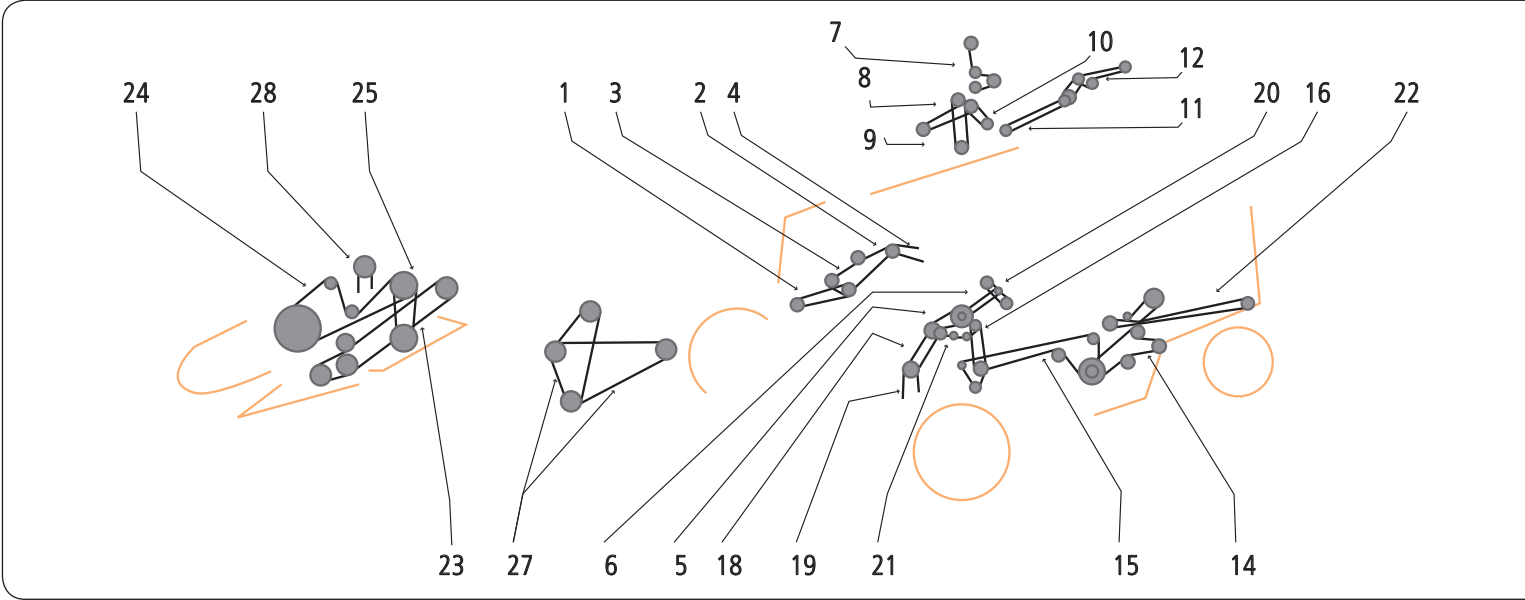

ITEM	APPLICATION	QUANTITY OF V-BELTS IN DRIVE	OE PART NUMBER	COMMENT
1	HYDRAULIC PUMP DRIVE	1	842413M1	
2	RADIATOR AND FAN DRIVE (S/N < 16559)	1	259047M91	
2	RADIATOR AND FAN DRIVE (S/N >= 15559)	1	284633M91	
3	ALTERNATOR, 6-CYL. ENGINE	1	844079M1	
4	AIR CONDITIONING COMPRESSOR	1	529964M1	
5	MAIN DRIVE	1	833865M1	
6	ROTARY SCREEN COUNTERSHAFT	1	833867M1	
7	RETURNS ELEVATOR	1	833854M2	
9	HYDRAULICREEL DRIVE	1	842845M1	
10	STRAW CHOPPER, FRONT	1	843948M1	X
11	STRAW CHOPPER, CENTER	1	843747M1	
12	STRAW CHOPPER, REAR 102.5 INCH	1	843760M1	
12	STRAW CHOPPER, REAR 224 INCH	1	844496M1	X
13	STRAW SPREADER, REAR	1	842110M1	
14	STRAW WALKER DRIVE	1	843302M1	
15	SHAKER SHOE	1	273757M91	
16	SHAKER SHOE - COUNTERSHAFT - FAN	1	281560M1	
17	CLEANING FAN	1	833863M1	X
17	CLEANING FAN, SMALL SEED KIT	1	842423M1	X
18	TRACTION, UPPER, 4 SPEED	1	833858M4	X
18	TRACTION, UPPER (S/N < 18278)	1	833866M1	X
18	TRACTION, UPPER (S/N >= 18278)	1	844336M1	X
19	TRACTION, LOWER, 4 SPEED (S/N >= 19115)	1	833857M4	X
19	TRACTION, LOWER, 4 SPEED (S/N < 19115)	1	833858M4	X
19	TRACTION, LOWER (S/N < 18278)	1	833866M1	X
19	TRACTION, LOWER (S/N >= 18278)	1	844336M1	X
20	COUNTERSHAFT TO ROTARY SCREEN	1	844306M1	X
21	TANK UNLOADER	1	833862M3	
22	WOBBLE BOX, FLOATING 22 FT.	1	227455M1	
22	WOBBLE BOX, FLOATING 22 FT.	1	832832M1	X
22	WOBBLE BOX, FLOATING 15 FT. - 20 FT.	1	833962M1	
23	WOBBLE BOX, RIGID CUT BAR 15 FT. - 20 FT. TABLE	1	195671M1	
23	WOBBLE BOX, RIGID CUT BAR, 22 FT. & 24 FT. TABLE	1	210774M1	X
23	WOBBLE BOX	1	834190M1	
23	DRAPER TABLE	1	842809M1	
24	REEL	1	834140M1	
25	REEL COUNTERSHAFT	1	834139M1	
27	ALT. - WATER PUMP 8V. ENGINE	1	844163M1	X

X - not in standard offer

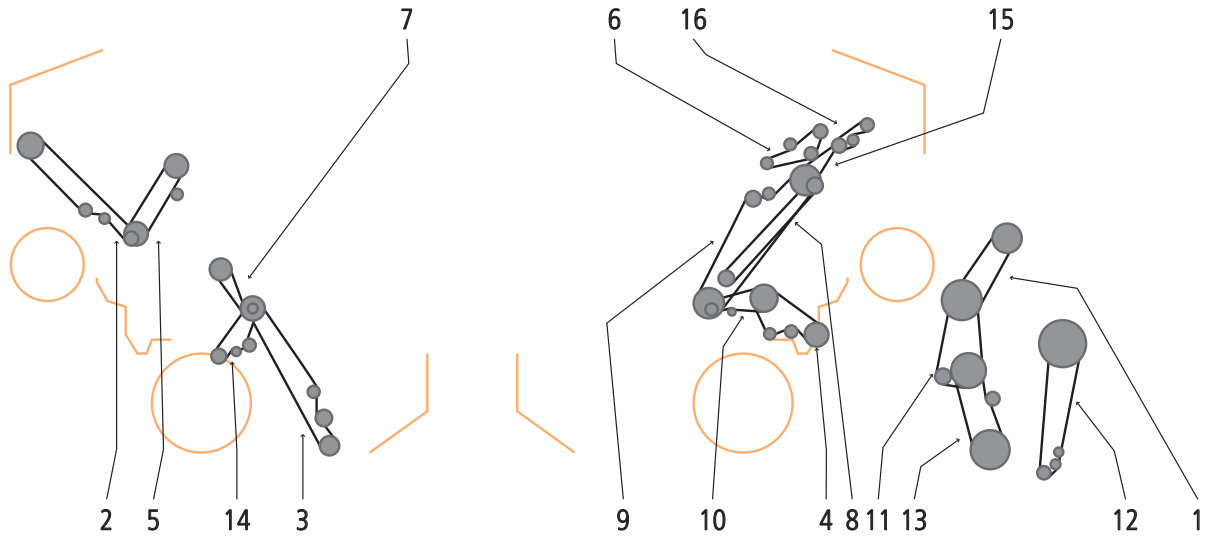

ITEM	APPLICATION	QUANTITY OF V-BELTS IN DRIVE	OE PART NUMBER	COMMENT
1	AC COMPRESSOR DRIVE	1	525906M1	
2	SPREADER DRIVE	1	168023W1	X
2	CHOPPER DRIVE	1	178128W1	X
3	TABLE DRIVE FEEDER (3V) 218	1	2621170W1	
4	GRAIN ELEVATOR DRIVE	1	227455M1	
5	JACKSHAFT DRIVE. SPREADER	1	227455M1	
6	PROPULSION PUMP DRIVE	1	9811830W2	
7	RETURN ELEVATOR DRIVE	1	619760W1	X
8	UNLOADER	1	101102M1	
9	BEATER DRIVE	1	624390W1	X
10	SHAKER SHOE PITMAN DRIVE	1	2593000W1	
11	ALTERNATOR AND FAN DRIVE	1	2634420W1	X
12	ROTARY SCREEN DRIVE	1	1764410W1	
13	ROTARY SCREEN C S	1	2634420W1	X
14	FAN DRIVE. VARI-SPEED	1	2612330W1	X
15	FEED IMPELLER DRIVE (3V) 123	1	1594240W1	
16	ROTOR DRIVE	1	1669570W1	

X - not in standard offer

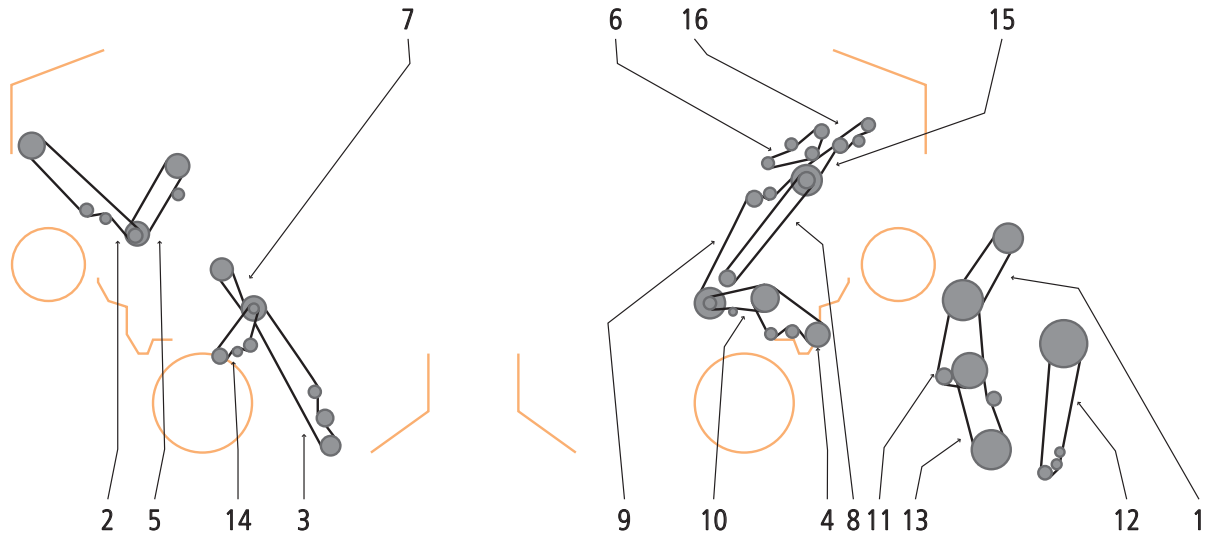

ITEM	APPLICATION	QUANTITY OF V-BELTS IN DRIVE	OE PART NUMBER	COMMENT
1	AC COMPRESSOR DRIVE	1	531603M1	X
2	CHOPPER DRIVE	1	103320M1	
2	SPREADER DRIVE	1	1680230W1	
3	HIGH CAPACITY FEEDER DRIVE (4 RIB BELT)	1	104072W1	
3	STANDARD FEEDER DRIVE (REPL. 2621 170 W1)	1	108190W1	
3	STANDARD FEEDER DRIVE (3 RIB BELT)	1	2621170W1	
4	GRAIN ELEVATOR DRIVE	1	227455M1	
5	CHOPPER JACKSHAFT	1	103319M1	
5	SPREADER JACKSHAFT	1	227455M1	
6	PROPULSION PUMP (240HP ENGINE)	1	104179W1	
6	PROPULSION PUMP (220HP ENGINE)	1	9811830W2	
7	RETURN ELEVATOR DRIVE	1	2619760W1	
8	UNLOADER	1	101102M1	
9	BEATER DRIVE	1	2624390W1	
10	SHAKER SHOE PITMAN DRIVE	1	2593000W1	
11	ALTERNATOR AND FAN DRIVE (S/N < 45050296)	1	1076753M1	X
11	ALTERN. AND FAN DRIVE (S/N > 45050296 AND 240HP ENG.)	1	111677W1	X
12	ROTARY SCREEN DRIVE	1	1764410W1	
13	ROTARY SCREEN COUNTERSHAFT (240HP ENG.)	1	104259W1	
13	ROTARY SCREEN COUNTERSHAFT (220HP ENG.)	1	2624080W1	
14	FAN DRIVE (VARI-DRIVE)	1	2612330W1	X
15	MAIN COUNTERSHAFT DRIVE (240HP ENG.)	1	104180W1	
15	MAIN COUNTERSHAFT DRIVE (220HP ENG.)	1	1594240W1	
16	ROTOR PUMP DRIVE	1	9811830W2	

X - not in standard offer

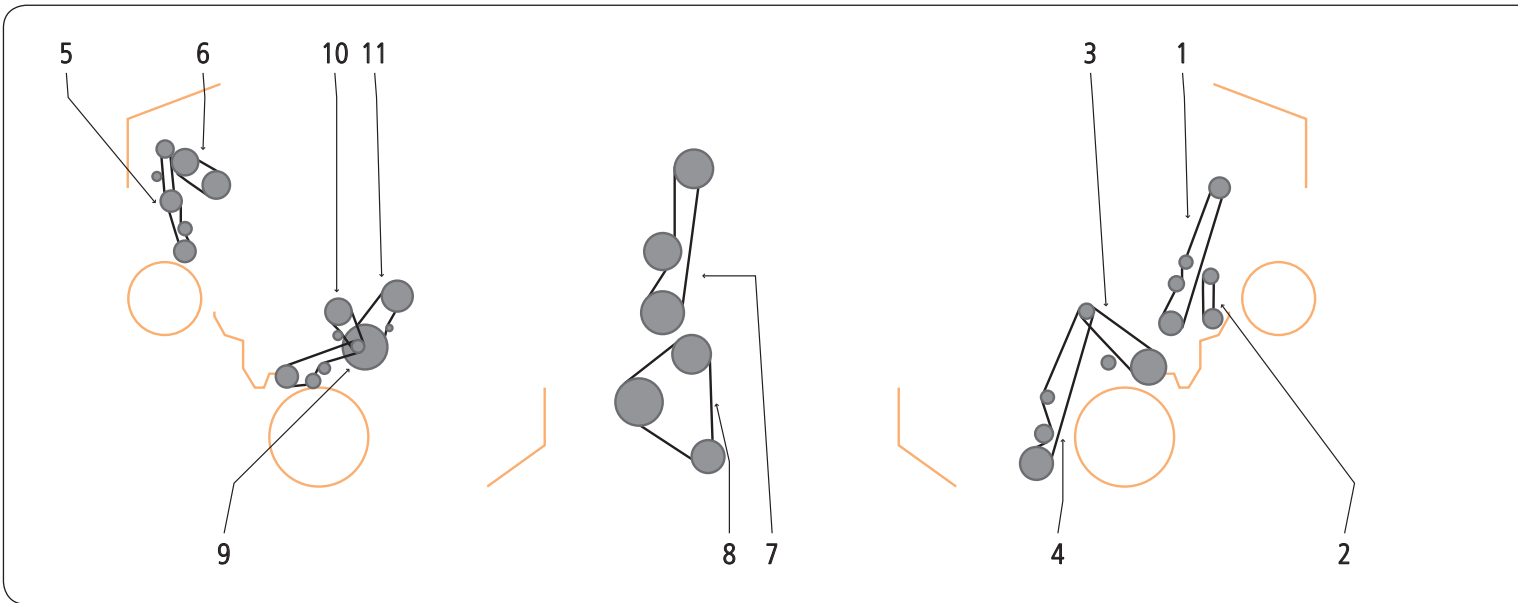

ITEM	APPLICATION	QUANTITY OF V-BELTS IN DRIVE	OE PART NUMBER	COMMENT
1	UNLOADER DRIVE	1	2496110W1	X
2	GRAIN ELEVATOR DRIVE	1	2439700W1	X
3	SHAKER SHOE PITMAN DRIVE	1	2439710W1	X
4	HEAD COUNTERSHAFT DRIVE	1	2523670W1	X
5	CHOPPER DRIVE	1	2553480W1	X
6	ROTOR DRIVE	1	2445370W1	X
7	STRAW SPREADER	1	2543960W1	X
8	STRAW SPREADER (SECONDARY)	1	2543970W1	X
9	CLEANING FAN DRIVE	1	2439720W1	X
10	RETURN ELEVATOR DRIVE	1	2492070W1	X
11	FEED IMPELLER DRIVE	1	1594240W1	

X - not in standard offer

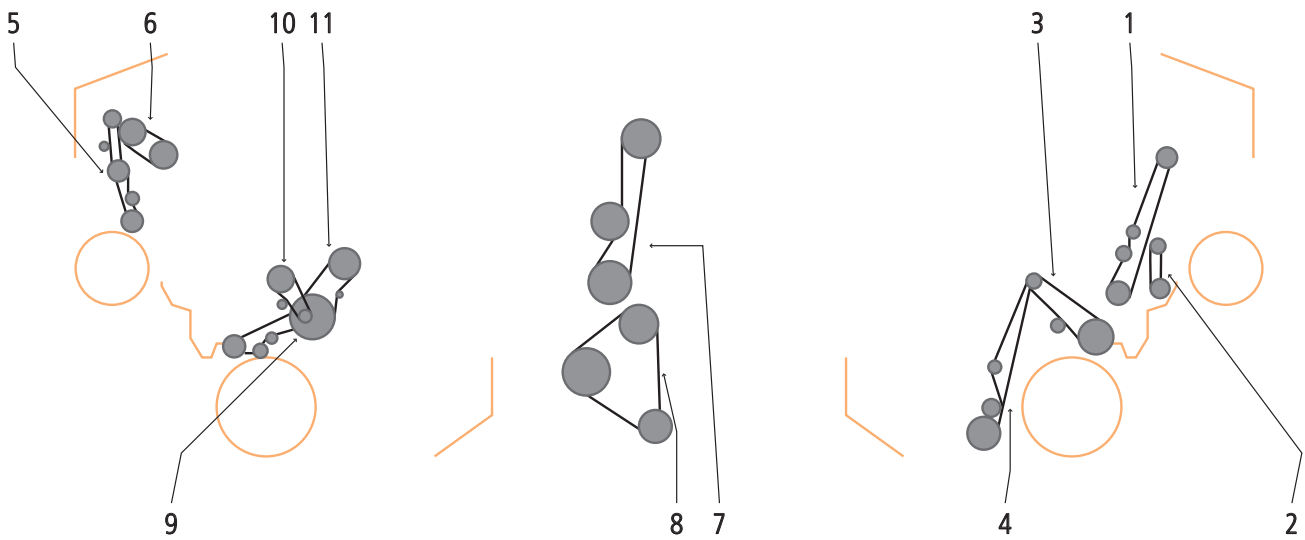

ITEM	APPLICATION	QUANTITY OF V-BELTS IN DRIVE	OE PART NUMBER	COMMENT
1	UNLOADER DRIVE	1	2496110W1	X
1	HEAD COUNTERSHAFT DRIVE	1	31-253670	X
2	GRAIN ELEVATOR DRIVE	1	2439700W1	X
2	PITMAN DRIVE	1	31-249710	X
3	SHAKER SHOE PITMAN DRIVE	1	2439710W1	X
3	GRAIN ELEVATOR DRIVE (PRIMARY)	1	31-2439700	
4	HEAD COUNTERSHAFT DRIVE	1	2523670W1	X
4	UNLOADER DRIVE (SECONDARY)	1	31-2496110	
5	CHOPPER DRIVE	1	2553480W1	X
5	ROTARY SCREEN DRIVE	1	31-2448930	
6	ROTOR DRIVE	1	2445370W1	X
6	AC COMPRESSOR DRIVE	1	31-2498110	X
7	STRAW SPREADER	1	2543960W1	X
7	ALTERNATOR DRIVE	1	31-2403270	X
8	STRAW SPREADER (SECONDARY)	1	2543970W1	X
8	WATER PUMP DRIVE	1	31-2414670	
9	CLEANING FAN DRIVE	1	2439720W1	X
9	RADIATOR FAN AND COUNTERSHAFT DRIVE	1	31-2449290	
10	RETURN ELEVATOR DRIVE	1	2492070W1	X
10	HYDRAULIC PUMP DRIVE. SET OF 2	1	31-2604010	
11	FEED IMPELLER DRIVE	1	1594240W1	
11	HYDROSTATIC PUMP DRIVE	1	31-2449520	
12	UNLOADER PRIMARY DRIVE	1	31-2605020	
13	THRESHER DRIVE	1	31-2404170	
14	STRAW SPREADER (PRIMARY)	1	31-2543960	
15	STRAW SPREADER (SECONDARY)	1	31-2543970	
16	CLEANING FAN DRIVE	1	31-2439720	X
17	FEED IMPELLER DRIVE	1	31-1594240	
18	RETURN ELEVATOR DRIVE	1	31-2492070	
19	CROP CHOPPER DRIVE	1	31-2553480	
20	ROTOR DRIVE	1	31-2445370	X

X - not in standard offer

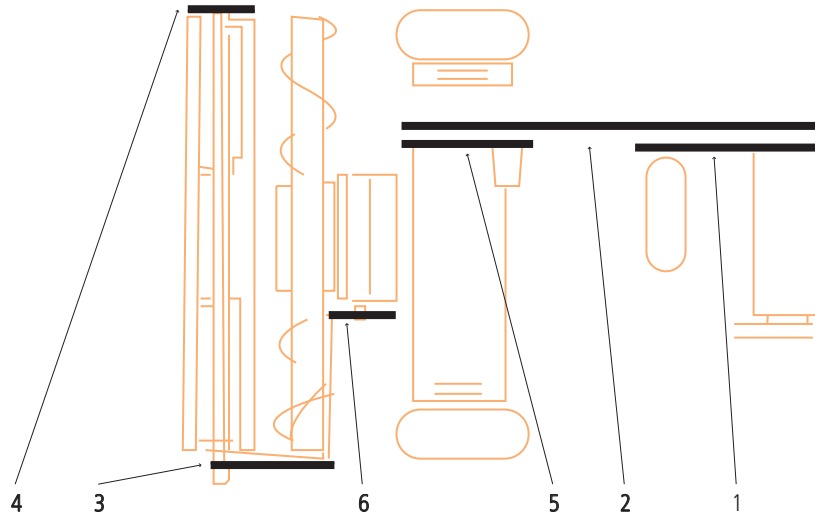

ITEM	APPLICATION	QUANTITY OF V-BELTS IN DRIVE	OE PART NUMBER	COMMENT
1	TRACTION DRIVE	1	1056409M1	
2	HEADER DRIVE	1	1056423M1	
3	SICKLE DRIVE	1	1056877M1	
4	REEL	1	1056914M1	
5	HYDRAULIC HEADER DRIVE	1	1057017M1	X
6	CONDITIONER	1	1071847M1	X

X - not in standard offer

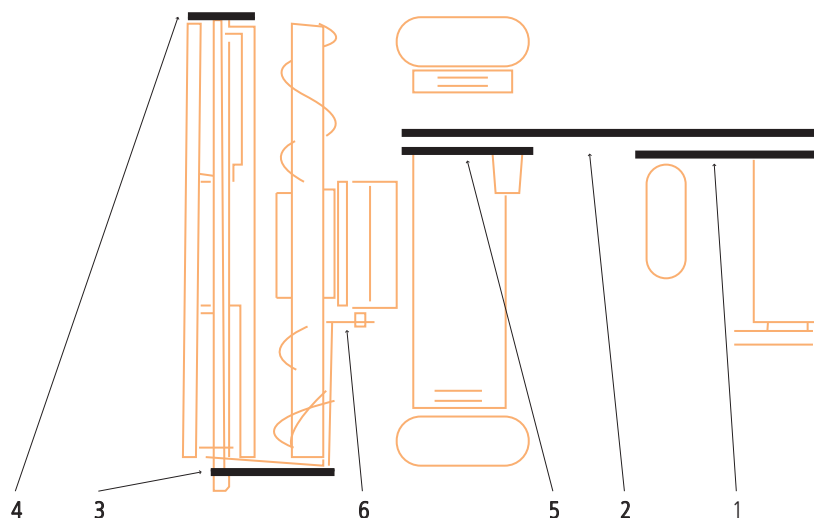

ITEM	APPLICATION	QUANTITY OF V-BELTS IN DRIVE	OE PART NUMBER	COMMENT
1	REEL DRIVE	1	80333255	
2	KNIFE DRIVE	1	80337415	
3	REEL VARIATOR	1	80334065	
4	INTERMEDIATE SHAFT - KNIFE	1	80330715	
5	STRAW ELEVATOR DRIVE	1	80230059	
6	GROUND SPEED VARI-DRIVE	1	80364418	X
7	BEATER DRIVE	1	80230079	
8	HYDRAULIC PUMP	1	80230043	
9	GROUND SPEED	1	80328424	
10	ECCENTRIC DRIVE	1	80230061	
11	STRAW WALKER	1	80230046	
12	FAN BELT (DEUTZ ENG)	1	80327040	
13	GENERATOR BELT (DEUTZ ENG)	1	80327041	
14	FAN BELT (FORD ENG)	1	80371222	
15	TAILINGS ELEVATOR	1	80230046	
16	UNLOADING SYSTEM	1	80326298	
17	DRUM VARI-DRIVE	1	80230078	
18	FAN VARI-DRIVE	1	80330204	

X - not in standard offer

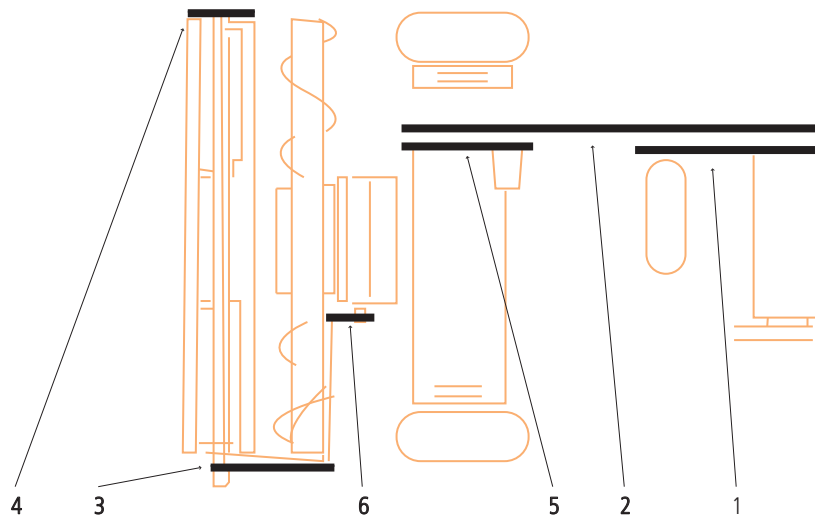

ITEM	APPLICATION	QUANTITY OF V-BELTS IN DRIVE	OE PART NUMBER	COMMENT
1	REEL DRIVE	1	80333255	
2	KNIFE DRIVE	1	80337415	
3	REEL VARIATOR DRIVE	1	80334065	
4	INTERMEDIATE KNIFE DRIVE	1	80330715	
5	STRAW ELEVATOR DRIVE	1	80230073	
6	ECCENTRIC DRIVE	1	80230060	
8	BEATER DRIVE	1	80230080	
8	AUGER DRIVE	1	80309364	
9	HYDRAULIC PUMP DRIVE	1	80230043	
11	FAN BELT (DEUTZ ENG)	1	80336386	
12	GENERATOR BELT (DEUTZ ENG)	1	80336426	
12	ALTERNATOR BELT (DEUTZ ENG)	1	80386155	X
13	FAN BELT	1	80371222	
14	GRAIN ELEVATOR DRIVE	1	80230059	
14	GRAIN ELEVATOR DRIVE	1	80230062	
15	FAN BELT (PERKINS ENGINE)	1	80353882	X
16	TAILINGS ELEVATOR DRIVE	1	80230057	
17	RETURN AUGER DRIVE	1	80230041	
18	UNLOADING SYSTEM	1	80230103	
19	DRUM VARI-DRIVE	1	80230078	
20	FAN VARI-DRIVE	1	80230056	
21	ECCENTRIC AND STRAW WALKER	1	80230108	

X - not in standard offer

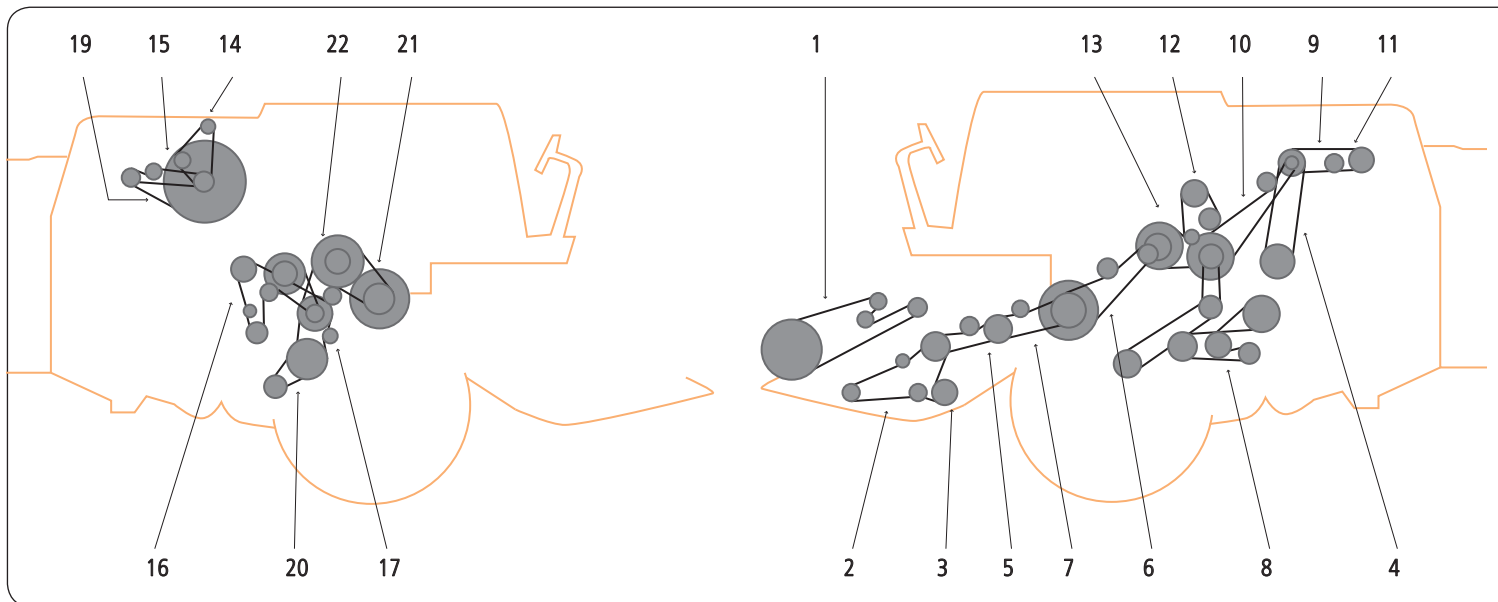

ITEM	APPLICATION	QUANTITY OF V-BELTS IN DRIVE	OE PART NUMBER	COMMENT
0	HYDRAULIC PUMP	1	80350236	
0	HYDRAULIC PUMP	1	80398748	
1	REEL DRIVE	1	80333255	
2	KNIFE DRIVE	1	80337415	
3	REEL SPEED VARI-DRIVE	1	80334065	
4	SICKLE KNIFE DRIVE	1	80362500	
5	DRIVE DRUM-VARIATOR	1	80336784	
6	HYDRAULIC PUMP	1	80335258	
7	MAIN SHAFT DRIVE	1	80323646	
8	UNLOADING SYSTEM	1	80333958	
9	DRUM VARI-DRIVE	1	80336784	
9	DRUM VARI-DRIVE	1	80355797	
12	GRAIN ELEVATOR DRIVE	1	80230164	
12	GRAIN ELEVATOR DRIVE	1	80353584	
13	ROTARY SCREEN DRIVE	1	80354338	X
14	TAILINGS ELEVATOR	1	80323413	
15	INTERMEDIATE REEL. KNIFE	1	80324391	
16	FAN DRIVE	1	80230059	
17	ECCENTRIC AND STRAW WALKER	1	80333347	
17	ECCENTRIC AND STRAW WALKER	1	80378672	
18	FAN VARI-DRIVE	1	80320935	X
19	DEUTZ ENGINE	1	80336386	
19	FORD ENGINE	1	80371222	
19	DEUTZ ENGINE	1	80386155	X

X - not in standard offer

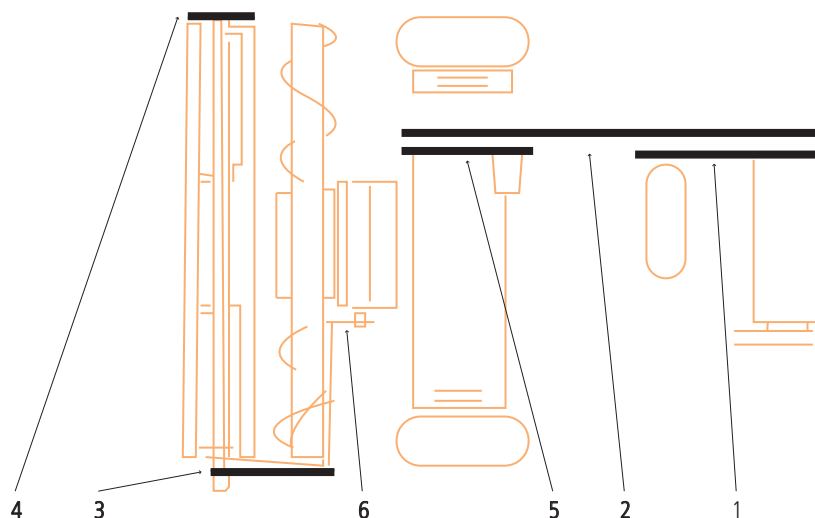

ITEM	APPLICATION	QUANTITY OF V-BELTS IN DRIVE	OE PART NUMBER	COMMENT
1	REEL DRIVE	1	80333255	
2	KNIFE DRIVE	1	80337415	
3	VARIABLE REEL SPEED	1	80334065	
4	INTERMEDIATE SHAFT. KNIFE	1	80643353	
5	STRAW ELEVATOR DRIVE	1	80230073	
6	ECCENTRIC DRIVE	1	80230060	
8	BEATER DRIVE	1	80230080	
9	HYDRAULIC PUMP	1	80230043	
10	UNLOADING SYSTEM	1	80309364	
11	STRAW WALKER	1	80230108	
12	FAN BELT FORD	1	80371222	
13	GRAIN ELEVATOR DRIVE	1	80230059	
13	GRAIN ELEVATOR	1	80230062	
14	TAILINGS ELEVATOR	1	80230057	
15	RETURN AUGER DRIVE	1	80230041	
16	DRUM VARI-DRIVE	1	80230078	
17	FAN VARI-DRIVE	1	80230056	

X - not in standard offer

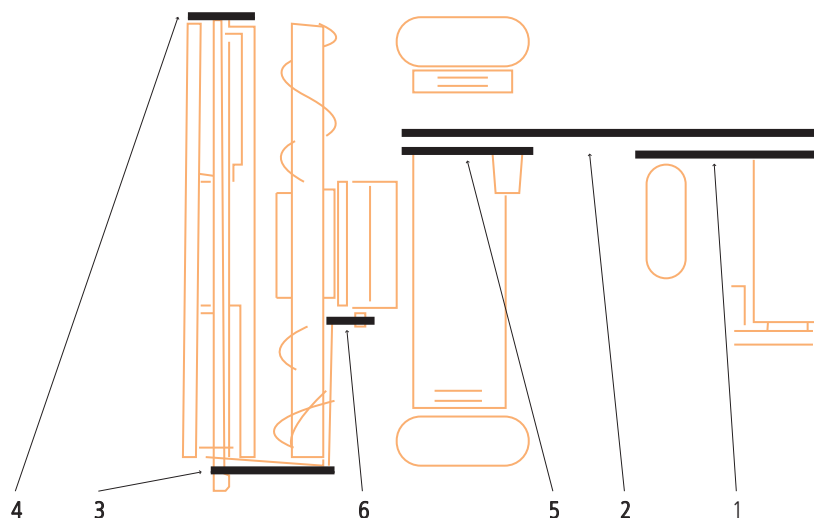

ITEM	APPLICATION	QUANTITY OF V-BELTS IN DRIVE	OE PART NUMBER	COMMENT
1	REEL DRIVE	80333255	1	
2	KNIFE DRIVE	80337415	1	
3	REEL VARIATOR	80334065	1	
4	INTERMEDIATE SHAFT. KNIFE	80362500	1	
5	DRUM VARIATOR	80336784	1	
6	HYDRAULIC PUMP	80230043	1	
6	HYDRAULIC PUMP	80335258	1	
7	MAIN SHAFT DRIVE	80323646	1	
8	UNLOADING SYSTEM	80333958	1	
9	DRUM VARI-DRIVE	80336784	1	
9	DRUM VARI-DRIVE	80355797	1	
10	GROUND SPEED	80356025	1	
11	GROUND SPEED VARI-DRIVE	80356025	1	
12	FAN BELT	80364033	1	
13	FAN BELT	80230039	1	
14	GRAIN ELEVATOR	80230164	1	
15	ROYARY SCREEN DRIVE	80354338	1	X
16	TAILINGS ELEVATOR	80323413	1	
17	INTERMEDIATE REEL. KNIFE	80324391	1	
18	FAN DRIVE	80320059	1	
19	ECCENTRIC AND STRAW WALKER	80333347	1	
19	STRAW WALKER	80378672	1	
20	FAN VARI-DRIVE	80320935	1	X
21	GRAIN ELEVATOR	80353584	1	
21	CENTRIFUGAL SEPARATOR	80356913	1	

X - not in standard offer

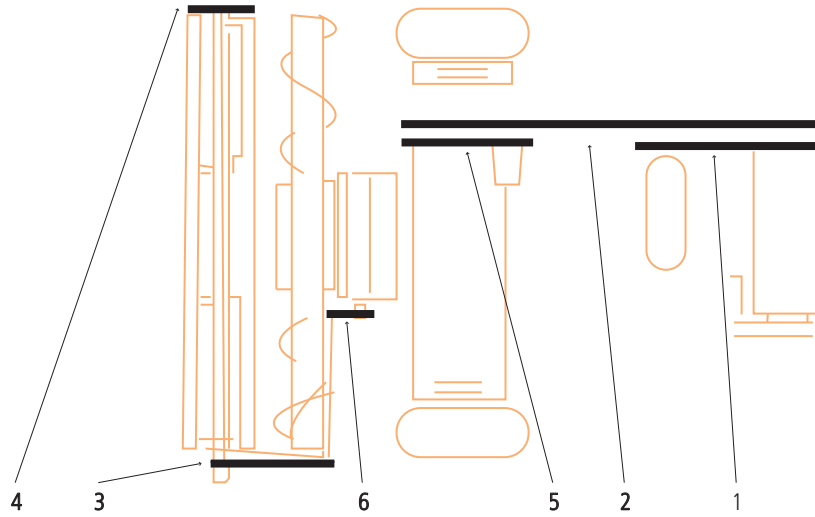

ITEM	APPLICATION	QUANTITY OF V-BELTS IN DRIVE	OE PART NUMBER	COMMENT
2	FORD ENGINE	1	80443634	
3	HYDRAULIC PUMP	1	80393519	
4	UNLOADING GRAIN TANK	1	80422725	
6	DRUM VARI-DRIVE	1	80336784	
7	FAN VARI-DRIVE	1	80230057	
8	FAN VARI-DRIVE	1	80395955	
9	ECCENTRIC AND STRAW WALKER DRIVE	1	80431784	
13	ELEVATOR DRIVE	1	80422731	
15	ECCENTRIC DRIVE	1	80387469	
16	STRAW ELEVATOR DRIVE	1	80066232	
17	HEADER DRIVE	1	80330715	

X - not in standard offer

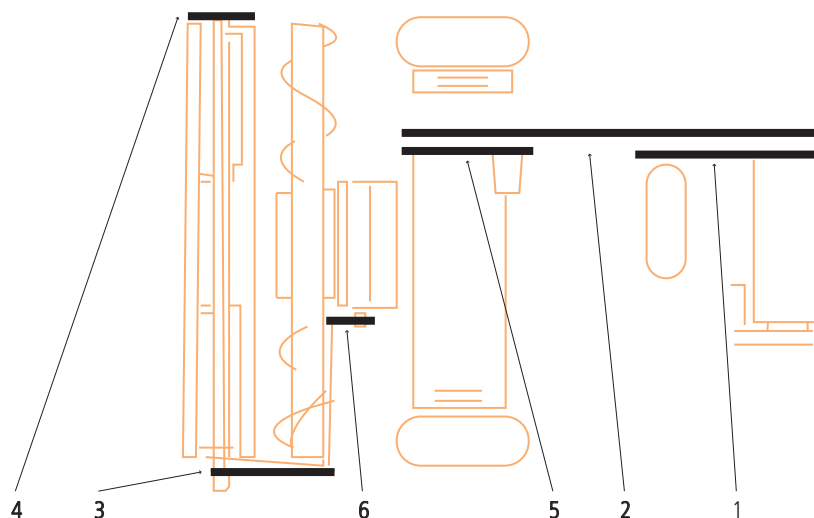

ITEM	APPLICATION	QUANTITY OF V-BELTS IN DRIVE	OE PART NUMBER	COMMENT
2	ALTERNATOR AND WATER PUMP DRIVE	1	80443634	
2	ALTERNATOR AND WATER PUMP DRIVE	1	80443636	X
3	RADIATOR FAN DRIVE	1	80427455	
5	DRUM VARI-DRIVE	1	80336784	
7	UPPER CLEANING FAN DRIVE	1	80230057	
8	LOWER CLEANING FAN DRIVE	1	80395955	
9	STRAW WALKER DRIVE	1	80431784	
10	BEATER DRIVE	1	80422281	
13	GRAIN ELEVATOR BOTTOM AUGER	1	80422731	
15	ECCENTRIC SHAFT DRIVE	1	80387469	
16	STRAW ELEVATOR DRIVE	1	80066232	
17	HEADER DRIVE	1	80330715	
18	ROTARY DUST SCREEN DRIVE	1	80422441	
19	INTERMEDIATE SHAFT DRIVE FOR FAN	1	80427456	
20	HYDRAULIC PUMP DRIVE	1	80393519	
21	GRAIN TANK BOTTOM AUGER	1	80230164	

X - not in standard offer

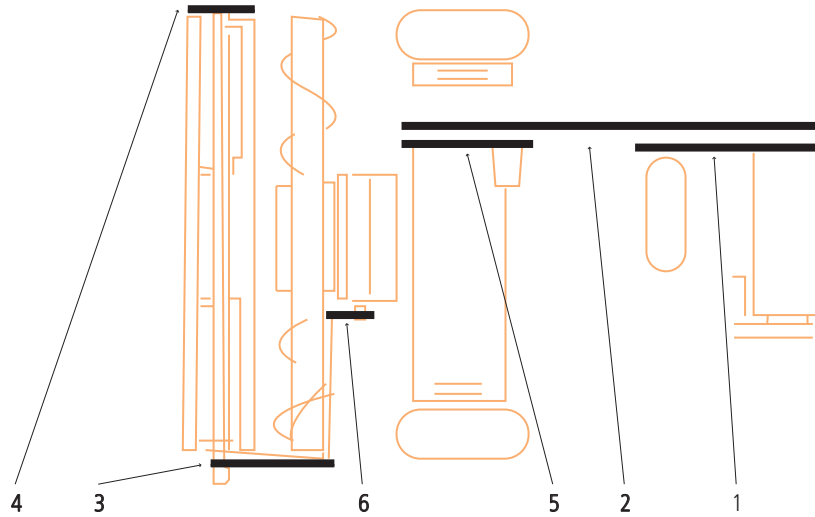

ITEM	APPLICATION	QUANTITY OF V-BELTS IN DRIVE	OE PART NUMBER	COMMENT
1	REEL DRIVE	1	80333255	
2	KNIFE DRIVE	1	80337415	
3	REEL SPEED VARI-DRIVE	1	80334065	
5	INTERMEDIATE SHAFT	1	80643353	
6	STRAW WALKER	1	80393326	
7	INTERMEDIATE DRIVE	1	80397297	
8	STRAW SHAKER	1	80605529	
11	HYDRAULIC PUMP	1	80230151	
11	ROTARY SCREEN DRIVE	1	80389245	
12	DISCHARGE AUGER	1	80410896	
13	MAIN SHAFT DRIVE	1	80397298	
14	FORD ENGINE	1	80371222	
15	FAN DRIVE	1	80399058	
16	DUST FILTER	1	80381489	
17	ELEVATOR	1	80387469	
18		1	80378989	
19	LOWER FAN DRIVE	1	80388280	
20	CYLINDER	1	80336784	
21	SET OF TWO BELTS	1	80396750	
22	SEPARATOR DRIVE	1	80395955	

X - not in standard offer

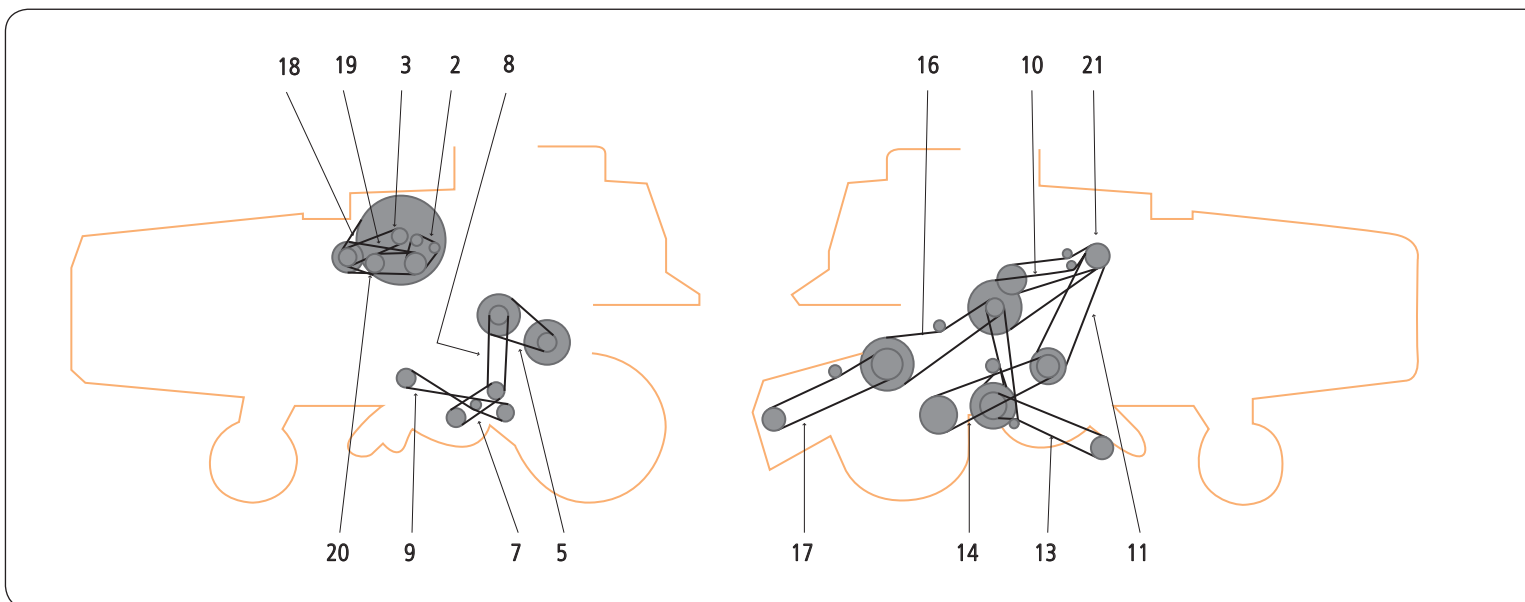

ITEM	APPLICATION	QUANTITY OF V-BELTS IN DRIVE	OE PART NUMBER	COMMENT
2	ALTERNATOR AND WATER PUMP DRIVE (FORD)	1	80443634	
2	ALTERNATOR AND WATER PUMP DRIVE (MERCEDES)	1	80444045	X
3	FAN DRIVE	1	80427455	
5	DRUM VARI-DRIVE	1	80336784	
7	FAN DRIVE	1	80230057	
8	FAN DRIVE	1	80395955	
9	STRAW WALKER DRIVE	1	80431784	
10	BEATER DRIVE	1	80447031	
13	GRAIN ELEVATOR BOTTOM AUGER	1	80422731	
15	ECCENTRIC SHAFT DRIVE	1	80387469	
16	STRAW ELEVATOR DRIVE	1	80066232	
16	STRAW ELEVATOR DRIVE	1	80424563	
17	HEADER DRIVE	1	80394426	
18	ROTARY DUST SCREEN DRIVE	1	80422441	
19	INTERMEDIATE SHAFT (DUST SCREEN DRIVE)	1	80427456	
20	HYDRAULIC PUMP DRIVE	1	80393519	
21	INTERMEDIATE DRIVE SHAFT	1	80447041	

X - not in standard offer

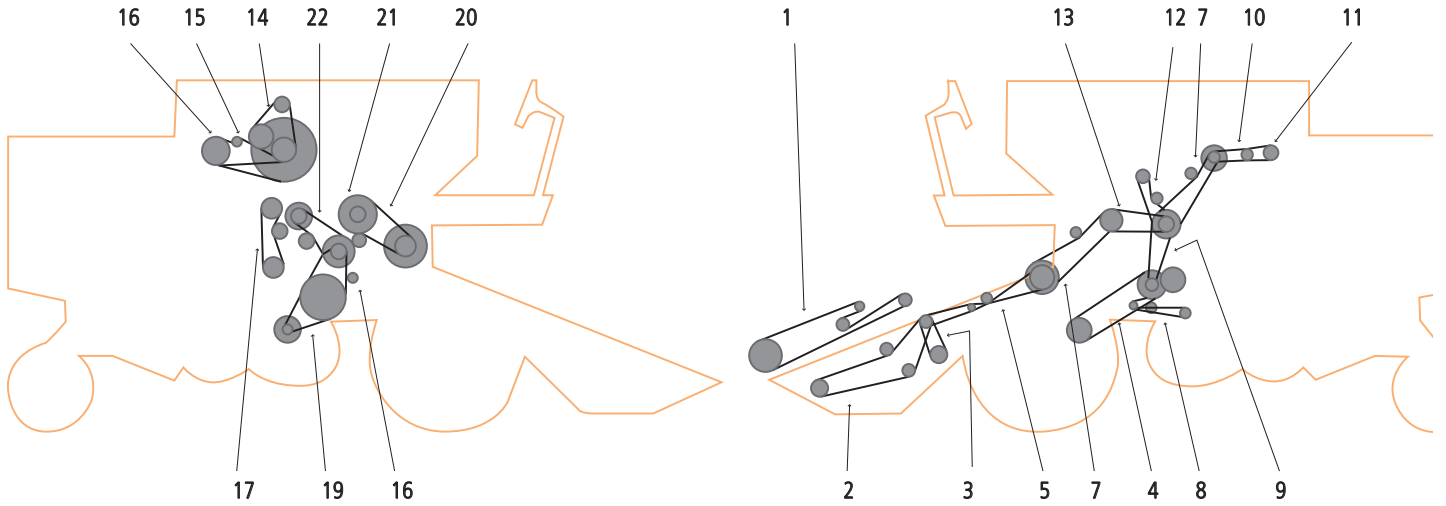

ITEM	APPLICATION	QUANTITY OF V-BELTS IN DRIVE	OE PART NUMBER	COMMENT
1	REEL DRIVE	1	80333255	
2	KNIFE DRIVE	1	80337415	
3	REEL SPEED VARI-DRIVE	1	80334065	
5	CUTTING TABLE	1	80394426	
6	STRAW WALKER	1	80393326	
7	INTERMEDIATE DRIVE	1	80397297	
8	STRAW SHAKER	1	80605529	
10	HYDRAULIC PUMP	1	80230151	
11	ROTARY DUST SCREEN DRIVE	1	80389245	
12	DISCHARGE AUGER	1	80410896	
13	MAIN SHAFT DRIVE	1	80397298	
14	ALTERNATOR DRIVE (MERCEDES OM 352A)	1	80421173	
14	ALTERNATOR DRIVE (FORD 2704 ET)	1	80371222	
15	FAN DRIVE	1	80399058	
16	DUST SCREEN DRIVE	1	80381489	
17	TAILINGS ELEVATOR DRIVE	1	80387469	
18	FAN DRIVE	1	80378989	
19	FAN VARI-DRIVE	1	80388280	
20	DRUM VARI-DRIVE	1	80336784	
21	COUNTER SHAFT DRIVE	1	80396750	
22	VARIATOR DRIVE	1	80395955	

X - not in standard offer

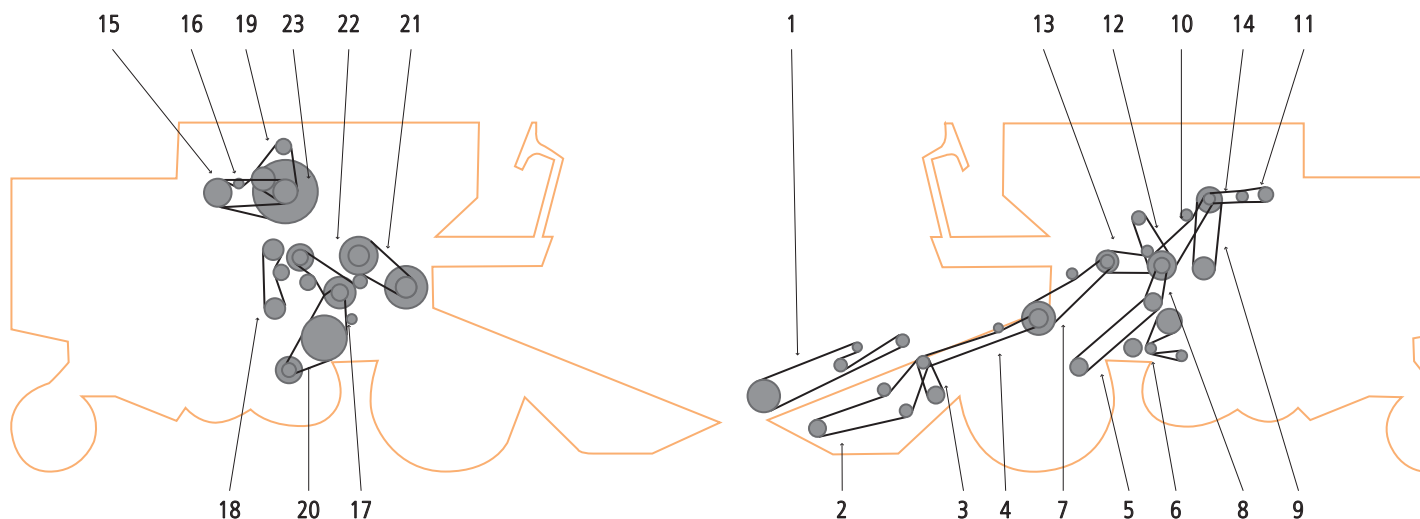

ITEM	APPLICATION	QUANTITY OF V-BELTS IN DRIVE	OE PART NUMBER	COMMENT
1	REEL DRIVE	1	80333255	
2	KNIFE DRIVE	1	80337415	
3	REEL SPEED VARI-DRIVE	1	80334065	
4	HEADER DRIVE	1	80394426	
5	GROUND SPEED VARI-DRIVE	1	80356025	
6	GROUND SPEED - LOW - PULLEY 350 MM	1	80417643	
6	GROUND SPEED - NORMAL - PULLEY 404 MM	1	80321559	
7	STRAW ELEVATOR DRIVE	1	80393326	
8	STRAW WALKER DRIVE	1	80605529	
9	HYDROSTATIC DRIVE	1	80411543	
10	DRUM VARIATOR	1	80391650	
11	INTERMEDIATE DRIVE SHAFT	1	80389245	
12	INTERMEDIATE SHAFT (GRAIN AUGER)	1	80410896	
13	RETHRESHER DRIVE	1	80387454	
13	RETHRESHER DRIVE	1	80451481	
14	HYDRAULIC PUMP DRIVE	1	80230151	
15	FAN DRIVE	1	80384397	
16	DUST SCREEN DRIVE	1	80381489	
17	FAN DRIVE	1	80378989	
18	TAILINGS ELEVATOR DRIVE	1	80387469	
19	ALTERNATOR DRIVE (MERCEDES OM 352A)	1	80421173	
19	ALTERNATOR DRIVE (FORD 2704 ET)	1	80371222	
20	FAN VARI-DRIVE	1	80388280	
21	DRUM VARI-DRIVE	1	80387460	X
22	COUNTERSHAFT DRIVE	1	80396750	
22	COUNTERSHAFT DRIVE	1	80437033	
23	VARIATOR DRIVE	1	80395955	

X - not in standard offer

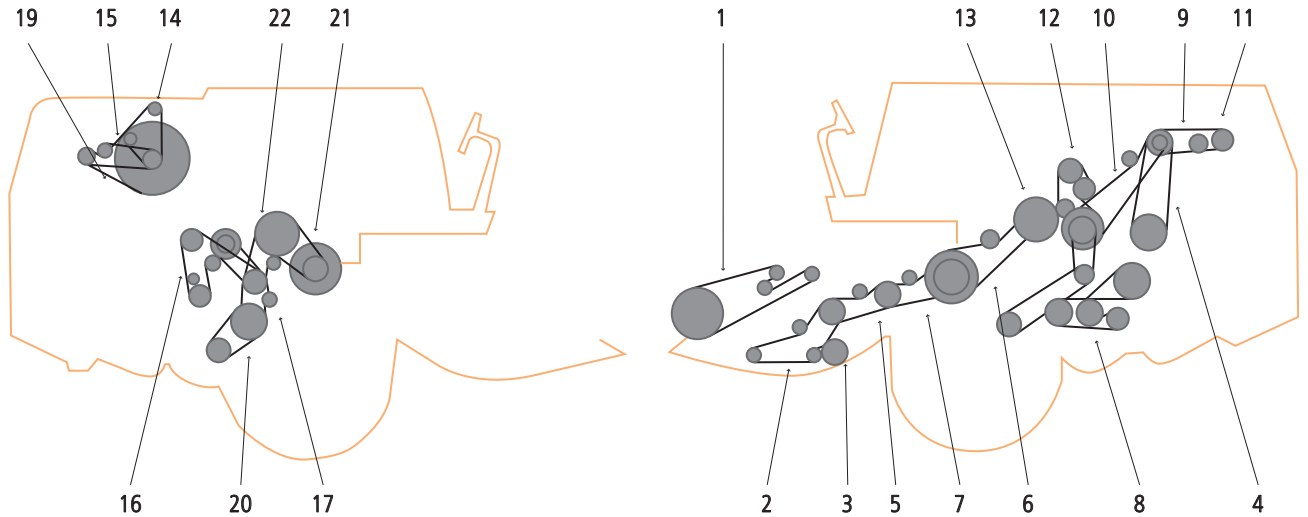

ITEM	APPLICATION	QUANTITY OF V-BELTS IN DRIVE	OE PART NUMBER	COMMENT
1	REEL DRIVE	1	80333255	
2	KNIFE DRIVE	1	80337415	
3	REEL SPEED VARI-DRIVE	1	80334065	
4	HYDROSTATIC DRIVE	1	80411543	
5	HEADER DRIVE	1	80387931	
6	STRAW ELEVATOR DRIVE	1	80393326	
7	HEADER DRIVE	1	80391143	
8	STRAW WALKER DRIVE	1	80605529	
9	HYDRAULIC PUMP DRIVE	1	80230151	
10	DRUM VARIATOR	1	80391650	
11	INTERMEDIATE DRIVE SHAFT	1	80389245	
12	INTERMEDIATE SHAFT (GRAIN AUGER)	1	80410896	
13	RETHRESHER DRIVE	1	80387454	
13	RETHRESHER DRIVE	1	80451481	
14	ALTERNATOR DRIVE (MERCEDES OM 401)	1	80393519	
14	ALTERNATOR DRIVE (MERCEDES OM 421)	1	80432642	
15	FAN DRIVE (MERCEDES OM 401)	1	80384397	
16	DUST SCREEN DRIVE	1	80381489	
17	FAN DRIVE	1	80378989	
18	TAILINGS ELEVATOR DRIVE	1	80387469	
20	FAN VARI-DRIVE	1	80388280	
21	DRUM VARI-DRIVE	1	80387460	X
22	COUNTERSHAFT DRIVE	1	80396750	
22	COUNTERSHAFT DRIVE	1	80437033	
23	VARIATOR DRIVE	1	80395955	

X - not in standard offer

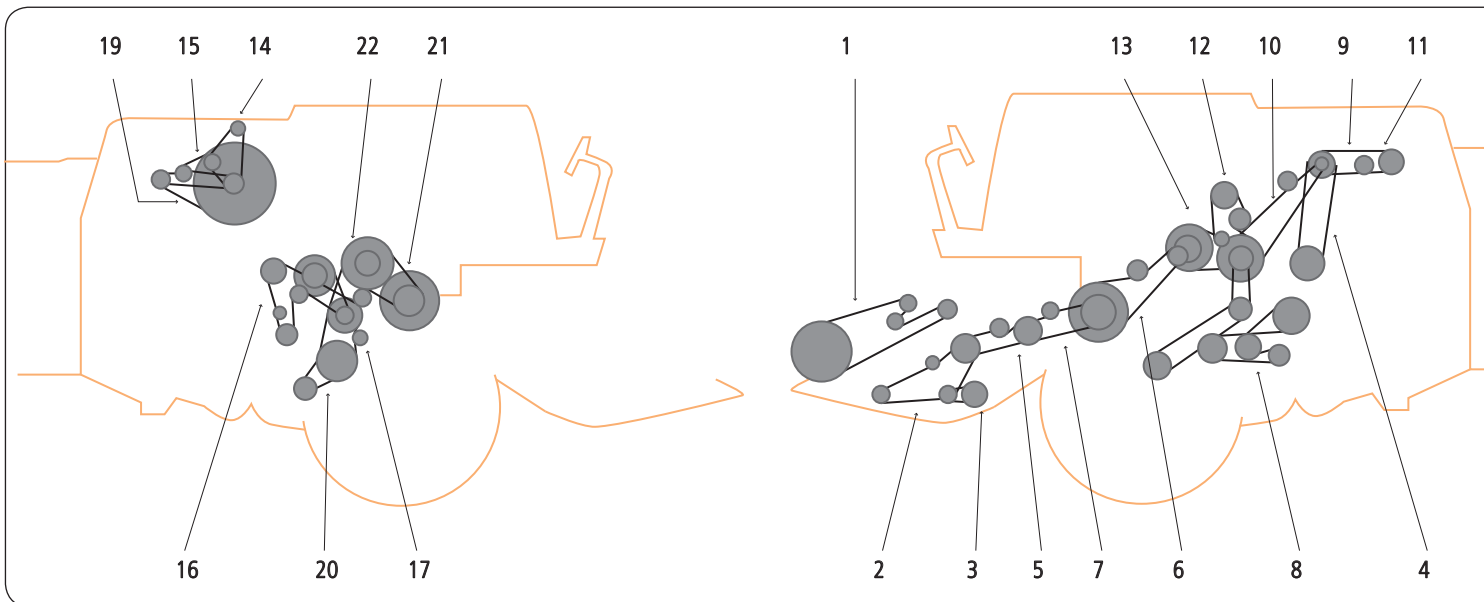

ITEM	APPLICATION	QUANTITY OF V-BELTS IN DRIVE	OE PART NUMBER	COMMENT
1	MAIN DRIVE	1	84017742	
2	DRIVE	1	84026761	
3	FAN	1	84012975	
4	ALTERNATOR	1	84022807	X
5	COMPRESSOR	1	80747177	
5	COMPRESSOR	1	89835815	X

X - not in standard offer

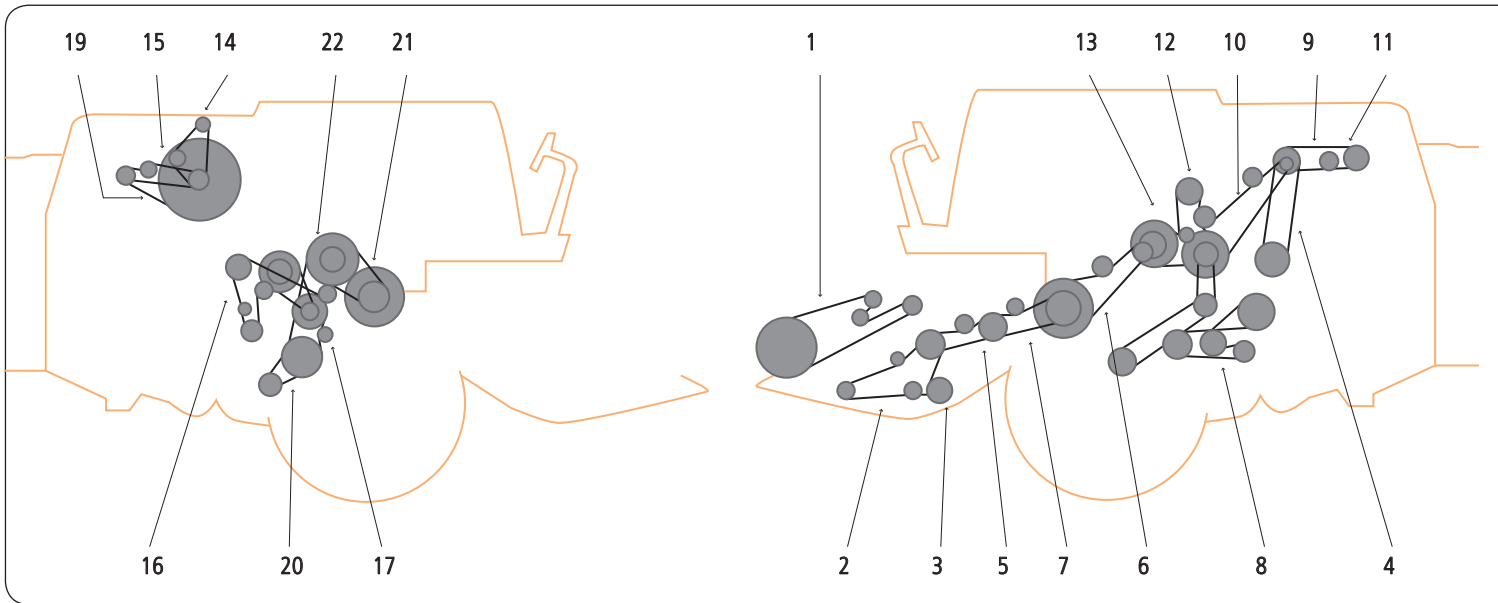

ITEM	APPLICATION	QUANTITY OF V-BELTS IN DRIVE	OE PART NUMBER	COMMENT
1	MAIN DRIVE	1	84017742	
2	DRIVE	1	84026761	
3	FAN	1	84012975	
4	ALTERNATOR	1	84022807	X
5	COMPRESSOR	1	80747177	
5	COMPRESSOR	1	89835815	X

X - not in standard offer

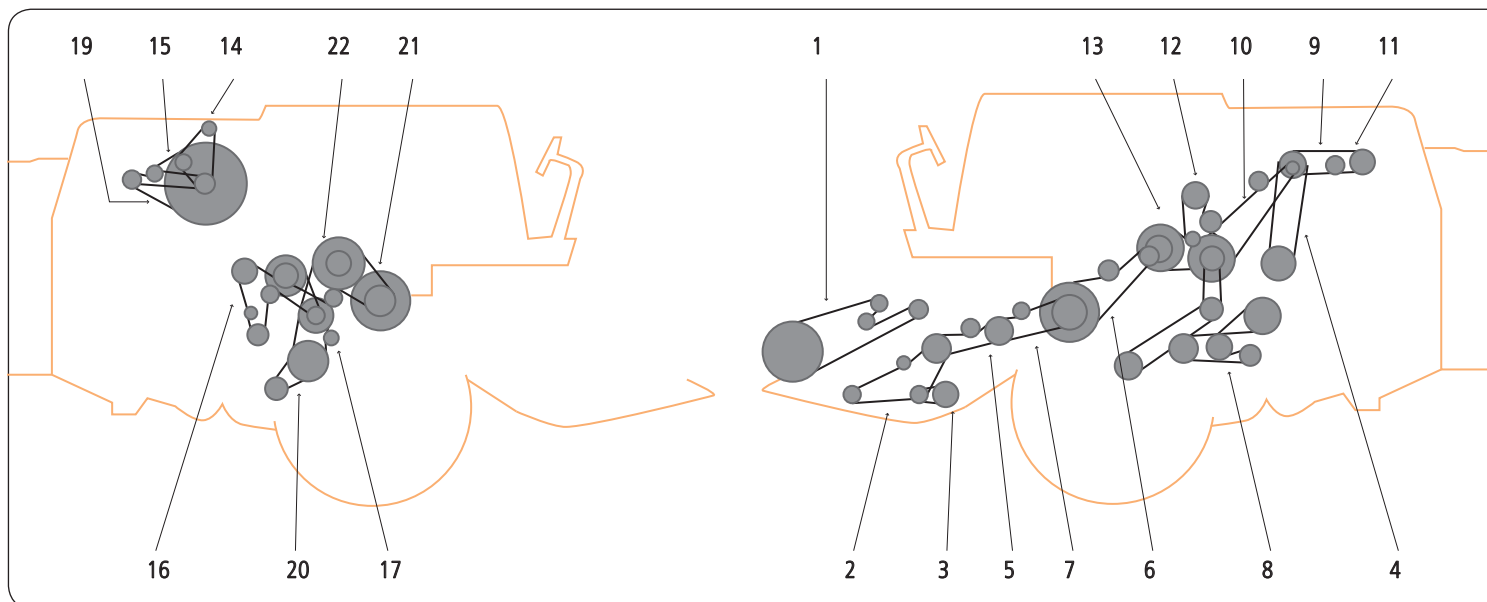

ITEM	APPLICATION	QUANTITY OF V-BELTS IN DRIVE	OE PART NUMBER	COMMENT
1	HYDRAULIC PUMP	1	80230043	
2	TAILINGS ELEVATOR	1	80230046	
3	DISCHARGE AUGER	1	80230048	
4	REEL INTERMEDIATE DRIVE	1	80230051	
5	STRAW ELEVATOR DRIVE	1	80230059	
6	REEL DRIVE	1	80230060	
7	STICKLE KNIFE DRIVE	1	80230060	
8	GRAIN TANK DRIVE	1	80230061	
9	STRAW BEATER	1	80230267	
10	GROUND SPEED	1	80230074	
11	FAN DRIVE	1	80230074	
12	GROUND SPEED VARIATOR	1	80230075	X
13	BEATER DRIVE	1	80230079	
14	FORD ENGINE	1	80230037	
14	DEUTZ ENGINE	1	80230127	
14	FORD ENGINE	1	80230131	
15	DEUTZ ENGINE	1	80230038	
16	GRAIN TANK AUGER	1	80230042	X
17	FAN	1	80230044	
18	ELEVATOR	1	80230046	
19	UNLOADING SYSTEM	1	80230053	
20	CYLINDER	1	80230078	

X - not in standard offer

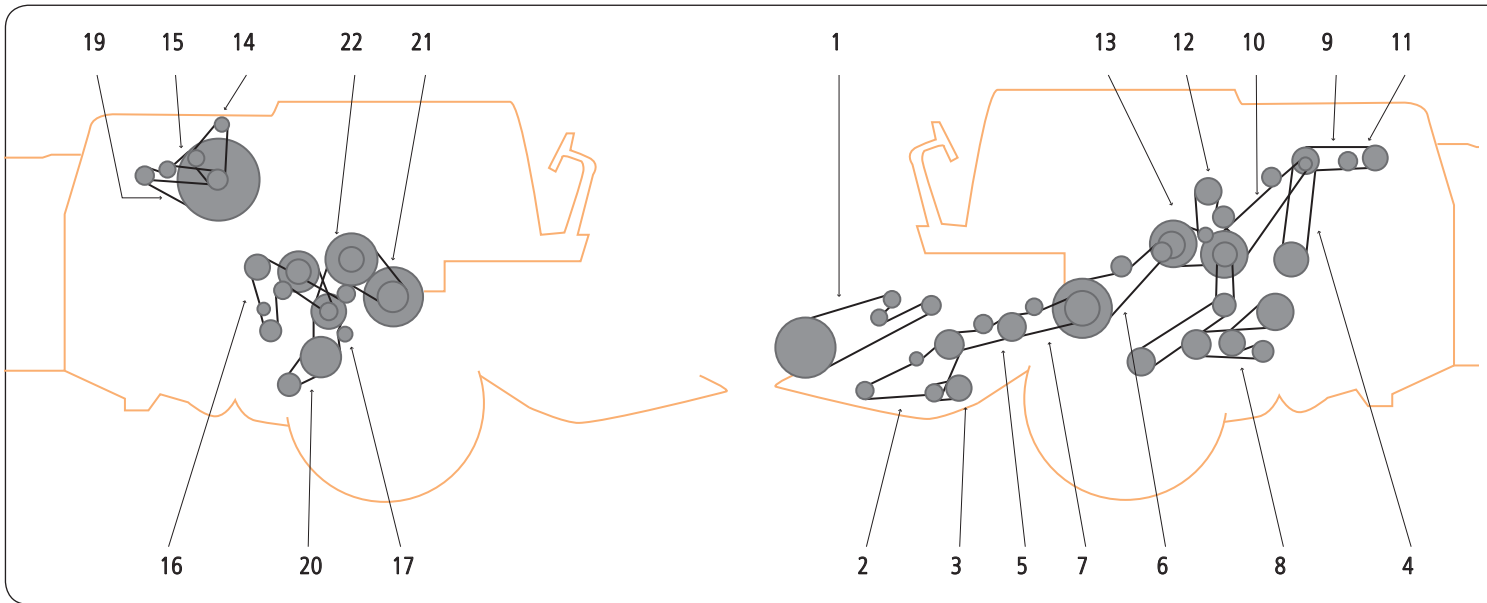

ITEM	APPLICATION	QUANTITY OF V-BELTS IN DRIVE	OE PART NUMBER	COMMENT
1	HYDRAULIC PUMP	1	80230043	
2	REEL INTERMEDIATE UPPER	1	80230051	
3	STRAW ELEVATOR DRIVE	1	80230059	
4	REEL DRIVE	1	80230060	
5	STICKLE KNIFE DRIVE	1	80230060	
6	GRAIN TANK DRIVE	1	80230061	
7	FAN DRIVE	1	80230074	
8	GROUND SPEED	1	80230075	X
9	BEATER DRIVE	1	80230079	
10	TAILINGS ELEVATOR	1	80230046	
11	GENERATOR DRIVE	1	80230038	
12	GRAIN TANK AUGER	1	80230042	X
13	FAN DRIVE	1	80230044	
14	ELEVATOR DRIVE	1	80230046	
15	UNLOADING SYSTEM	1	80230053	
16	CYLINDER	1	80230078	
17	FAN BELT	1	80230127	
17	FAN BELT	1	80230131	

X - not in standard offer

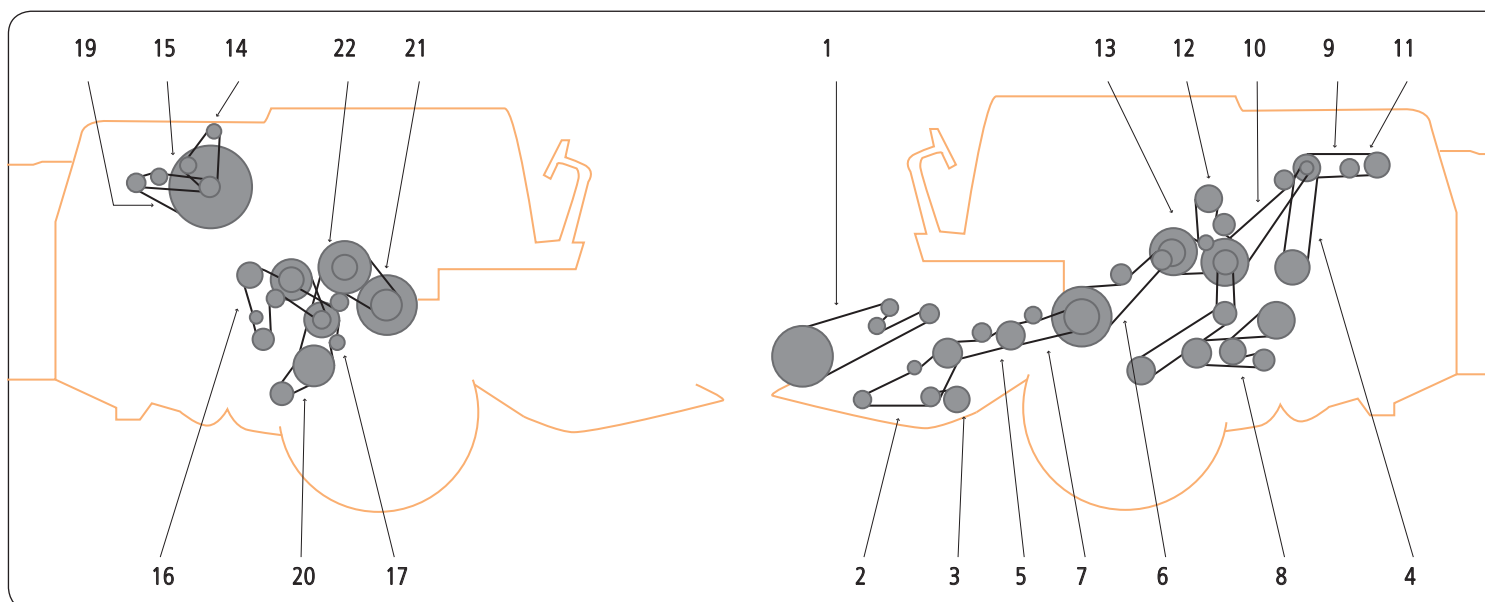

ITEM	APPLICATION	QUANTITY OF V-BELTS IN DRIVE	OE PART NUMBER	COMMENT
1	THRESHING DRUM DRIVE	1	80230078	
3	BEATER DRIVE	1	80230080	
4	STRAW WALKER DRIVE	1	80230064	
5	TAILINGS ELEVATOR	1	80230054	
6	STRAW ELEVATOR	1	80230073	
7	STICKLE KNIFE DRIVE	1	80230074	
8	REEL INTERMEDIATE SHAFT. LOWER	1	80230057	
9	REEL INTERMEDIATE SHAFT. UPPER	1	80230052	
10	REEL DRIVE	1	80230060	
11	HYDRAULIC PUMP DRIVE	1	80230043	
12	ENGINE FAN DRIVE - FORD	1	80230037	
12	ENGINE FAN DRIVE - PERKINS	1	80230051	
12	ENGINE COOLING BLOWER DRIVE - DEUTZ	1	80230127	
13	GENERATOR DRIVE - DEUTZ	1	80230038	
14	TAILINGS ELEVATOR RETURN	1	80230042	X
15	STRAW SPREADER DRIVE	1	80230049	
15	STRAW SPREADER DRIVE / TYPE 9501 M	1	80230050	
16	STRAW PRESS DRIVE	1	80230069	
16	STRAW PRESS DRIVE	1	80230070	
16	STRAW PRESS DRIVE	1	80230071	X
17	DISCHARGE AUGER	1	80230053	
18	POWER STEERING	1	80230043	
18	POWER STEERING	1	80230151	
19	STRAW CHOPPER DRIVE	1	80230068	
20	CHOFF BLOWER DRIVE	1	80230066	
21	MAIZE THRESHING DRUM DRIVE	1	80230056	
22	MAIZE REEL DRIVE	1	80230065	
23	MAIZE REEL DRIVE	1	80230063	
24	CHOFF BLOWER DRIVE	1	80230048	
24	CHOFF BLOWER DRIVE	1	80230154	
25	GRAIN TANK AUGER DRIVE	1	80230041	
26	GRAIN TANK AUGER DRIVE	1	80230045	
27	DIVIDING ROLLER	1	80230062	
28	FAN WHEEL DRIVE	1	80230040	

X - not in standard offer

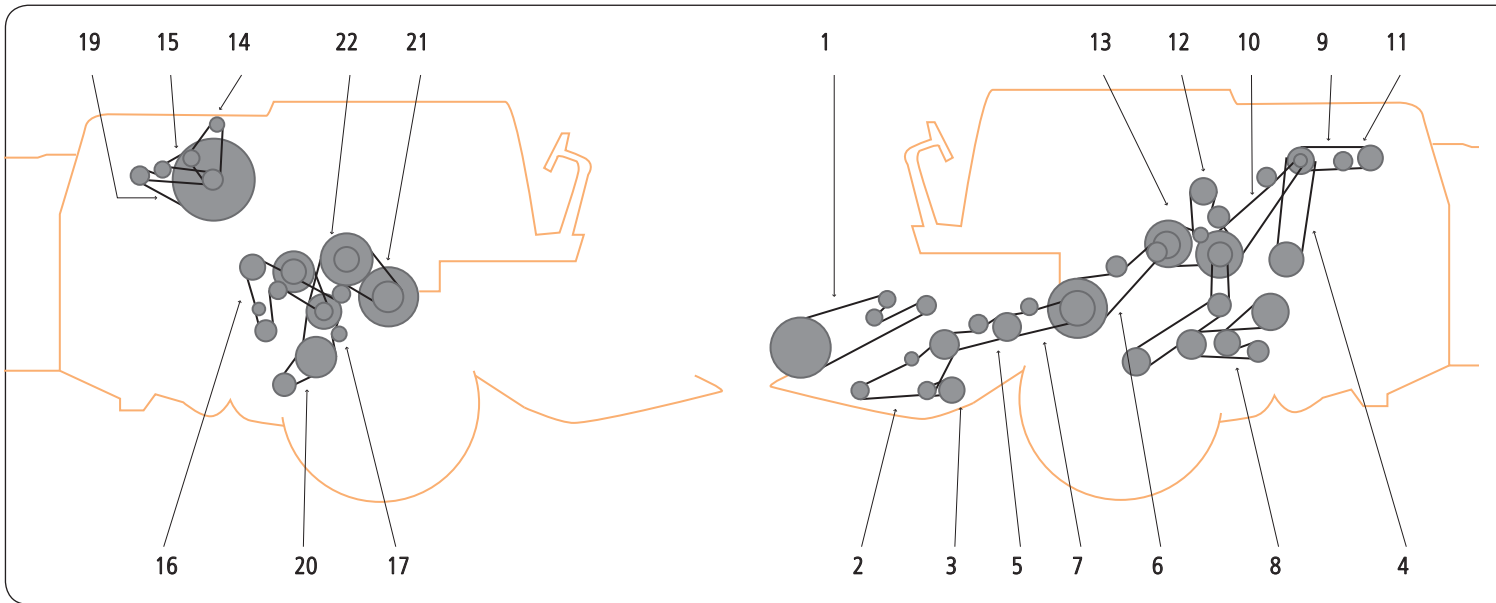

ITEM	APPLICATION	QUANTITY OF V-BELTS IN DRIVE	OE PART NUMBER	COMMENT
1	HYDRAULIC PUMP	1	80230043	
2	TAILINGS ELEVATOR	1	80230046	
3	STRAW ELEVATOR DRIVE	1	80230059	
4	GRAIN TANK DRIVE	1	80230061	
5	REEL DRIVE	1	80230061	
6	BEATER DRIVE	1	80230079	
7	REEL SPEED DRIVE	1	80230101	
8	SICKLE KNIFE DRIVE	1	80309087	
9	TRACTION DRIVE	1	80326954	X
10	TRACTION DRIVE	1	80328424	
11	ELEVATOR DRIVE	1	80230046	
12	CYLINDER	1	80230078	
13	UNLOADING SYSTEM	1	80326298	
14	FAN DRIVE	1	80330204	
15	DEUTZ ENGINE	1	80327040	
16	DEUTZ ENGINE	1	80327041	
17	FORD ENGINE	1	80327062	

X - not in standard offer

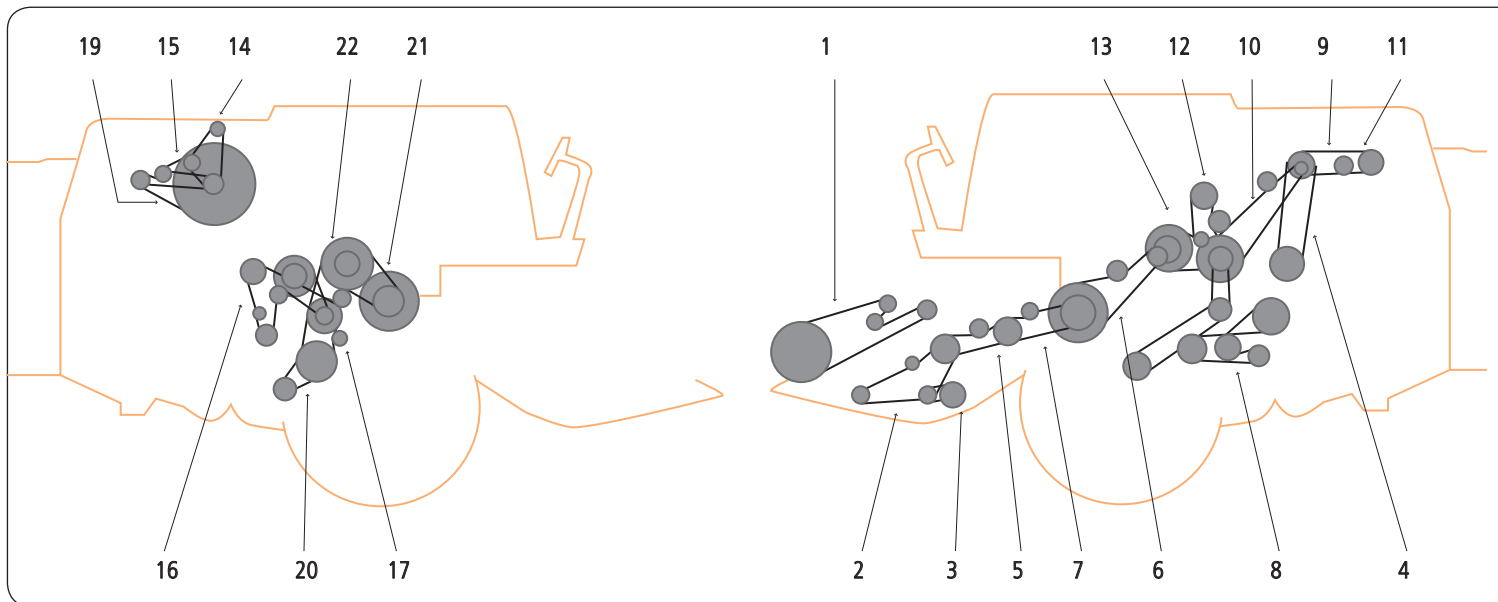

ITEM	APPLICATION	QUANTITY OF V-BELTS IN DRIVE	OE PART NUMBER	COMMENT
1	HYDRAULIC PUMP	1	80230043	
2	REEL ECCENTRIC DRIVE	1	80230060	
3	REEL DRIVE	1	80230061	
4	STRAW ELEVATOR DRIVE	1	80230073	
6	BEATER DRIVE	1	80230080	
7	CUTTING TABLE	1	80230074	
7	SICKLE KNIFE DRIVE	1	80309087	
8	REEL SPEED VARI-DRIVE	1	80230101	
9	STRAW FUNNEL	1	80309364	
10	ROTARY SCREEN	1	80230041	
11	FAN VARI-DRIVE	1	80230056	
12	TAILINGS ELEVATOR DRIVE	1	80230057	
12	GRAIN ELEVATOR	1	80230059	
13	ELEVATOR DRIVE	1	80230059	
14	CYLINDER	1	80230078	
15	ELEVATOR DRIVE M135	1	80230062	
16	DISCHARGE AUGER	1	80230103	
17	STRAW WALKER DRIVE	1	80230108	
18	FAN BELT	1	80327024	
18	FAN BELT	1	80336386	
19	GENERATOR DRIVE	1	80327041	
19	GENERATOR DRIVE	1	80336426	

X - not in standard offer

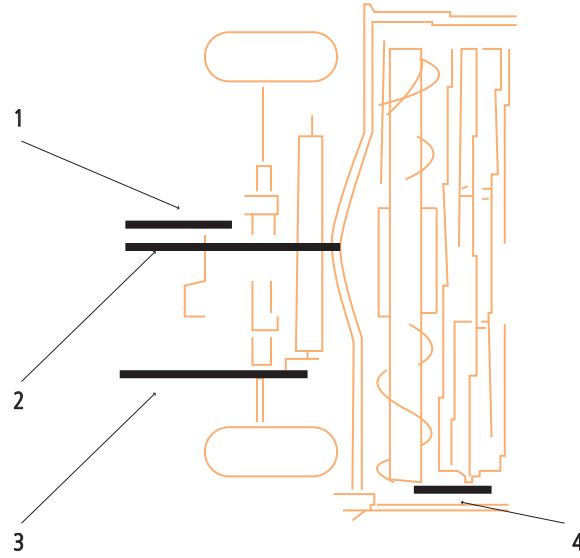

ITEM	APPLICATION	QUANTITY OF V-BELTS IN DRIVE	OE PART NUMBER	COMMENT
1	JACKSHAFT 3 BAND	1	189130	
2	HEADER DRIVE	1	182381	
3	CONDITIONING DRIVE 4 BAND	1	186623	
4	REEL	1	137695	
1	HEADER CLUTCH 3 GROOVE	1	189131	
2	HEADER 2 GROOVE	1	643307	
3	CONDITIONER	1	625241	X
4	REEL	1	189130	

X - not in standard offer

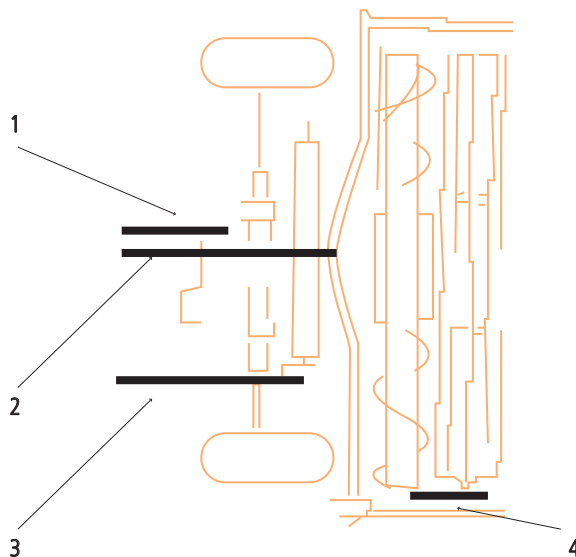

ITEM	APPLICATION	QUANTITY OF V-BELTS IN DRIVE	OE PART NUMBER	COMMENT
1	SICKLE DRIVE AND AUGER	1	703747	
2	CONDITIONER	1	131725	

X - not in standard offer

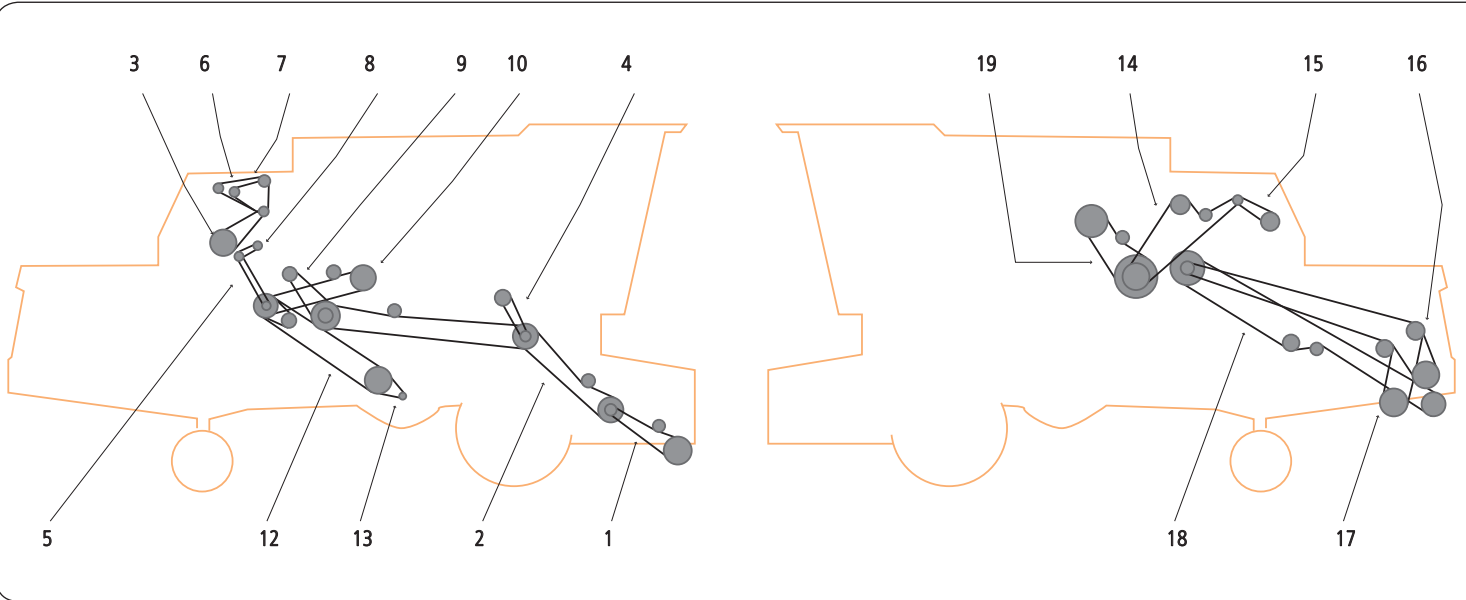

ITEM	APPLICATION	QUANTITY OF V-BELTS IN DRIVE	OE PART NUMBER	COMMENT
1	CLEANING FAN VARI-DRIVE	1	80284521	X
2	SHAKER SHOE DRIVE	1	80717699	
3	STRAW CHOPPER. FRONT	1	80619748	
4	STRAW CHOPPER. REAR	1	80614040	
5	ROTARY SCREEN. LOWER	1	80612305	
6	HYDRAULIC PUMP. TR 85	1	80248332	
6	HYDRAULIC PUMP. TR 75	1	80576772	
7	WATER PUMP AND ALTERNATOR. TR 85	1	80716253	
8	WATER PUMP ALTERNATOR. TR 75	1	80500594	X
9	ENGINE FAN. TR 85	1	80719213	X
9	ENGINE FAN. TR 75	1	80719214	X
10	ROTARY SCREEN. UPPER	1	80716254	X
11	ROTOR VARI-DRIVE	1	80717700	X
12	DISCHARGE BEATER	1	80621104	
13	CLEAN GRAIN ELEVATOR DRIVE	1	80703747	
14	HEADER DRIVE	1	80246980	
15	STRAW SPREADER DRIVE	1	80230143	
16	STRAW CHOPPER BEATER DRIVE	1	80246727	
17	STANDARD TRACTION VARI-DRIVE. UPPER	1	80261000	X
18	HYDROSTATIC DRIVE. UPPER	1	80716416	
19	STANDARD TRACTION VARI-DRIVE. LOWER	1	80261001	
20	HYDROSTATIC DRIVE. LOWER	1	80716414	
21	UNLOADING AUGER DRIVE	1	80247782	
22	MAIN SHAFT DRIVE. TR 85	1	80246978	
22	MAIN SHAFT DRIVE. TR 75	1	80576771	
23	AIR CONDITIONING COMPRESSOR. TR 85	1	80264557	
23	AIR CONDITIONING COMPRESSOR. TR 75	1	80576776	
24	HYDROSTATIC CHANGE PUMP	1	80259477	

X - not in standard offer

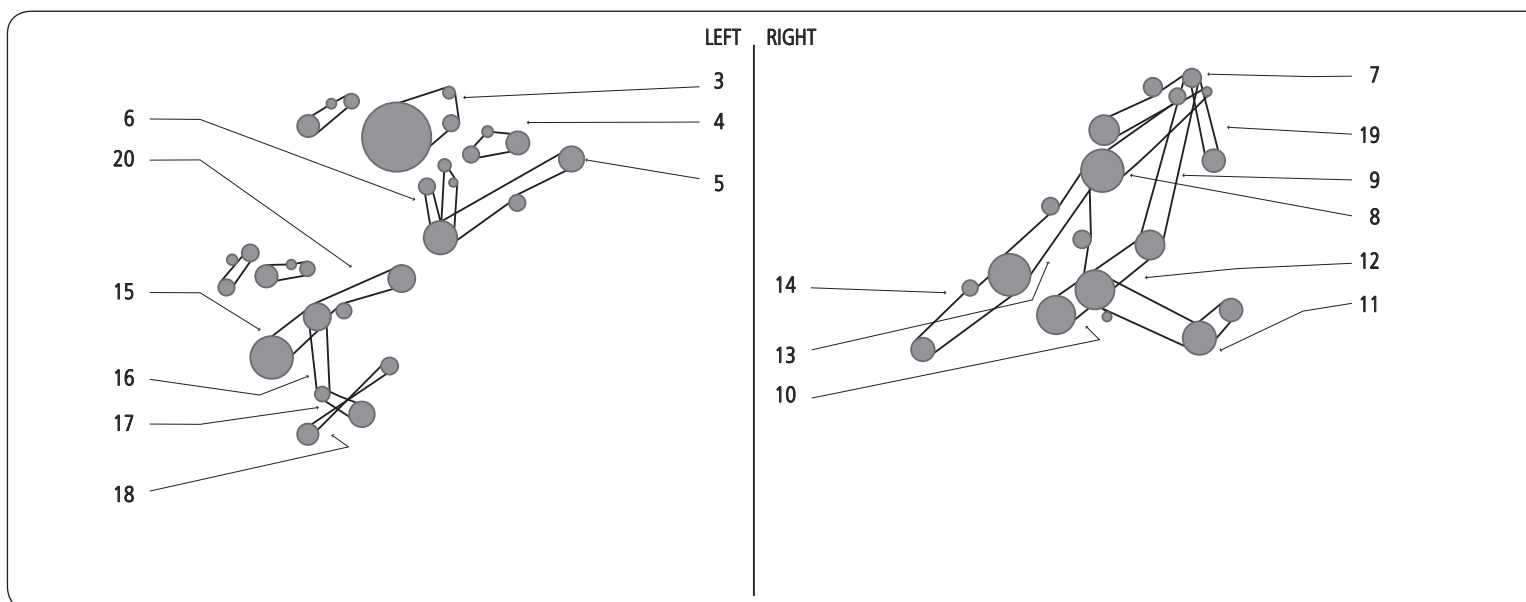

ITEM	APPLICATION	QUANTITY OF V-BELTS IN DRIVE	OE PART NUMBER	COMMENT
3	ROTARY DUST SCREEN	1	89514310	
4	RADIATOR FAN (FOR TC52 ONLY)	1	89831515	
4	RADIATOR FAN (FOR TC54-56 ONLY)	1	89818704	
5	ENGINE	1	89818705	
0	WATER PUMP - ALTERNATPR - ENG. (WO AIR CO)	1	84005860	X
7	INTERMEDIATE SHAFT - ENGINE	1	89838606	
8	BEATERSHAFT - MAIN DRIVE	1	89817374	
11	GRAIN AUGER	1	80422731	
12	BEATER SHAFT - ECCENTRIC SHAFT	1	80387469	
13	STRAW ELEVATOR - BEATER SHAFT	1	80066232	
13	STRAW ELEVATOR - BEATER SHAFT	1	80424563	
14	HEADER DRIVER (CODE 0209) TC56	1	89817487	
14	HEADER DRIVER (CODE 0212) TC52-54	1	89817487	
14	HEADER DRIVER (CODE 0212) TC 52-54	1	89817488	
14	HEADER DRIVER (CODE 0209) TC56	1	89817488	
14	HEADER DRIVER (CODE 1000) F.L. CONV. TC56	1	89835120	
14	HEADER DRIVER (CODE 1300) F.L. CONV. TC52-54	1	89835120	
14	HEADER DRIVER (CODE 1000) F.L. CONV. TC56	1	89839375	
14	HEADER DRIVER (CODE 1300) F.L. CONV. TC52-54	1	89839375	
15	DRUM - BEATER SHAFT	1	80336784	
16	BEATER SHAFT	1	89515075	
17	FAN	1	89515076	
18	STRAW WALKERS - ECCENTRIC SHAFT	1	80431784	
19	HYDROSTATIC PUMP (CODE 0800)	1	89818873	
20	ROTARY SEPARATOR (CODE 2300)	1	89837412	

X - not in standard offer

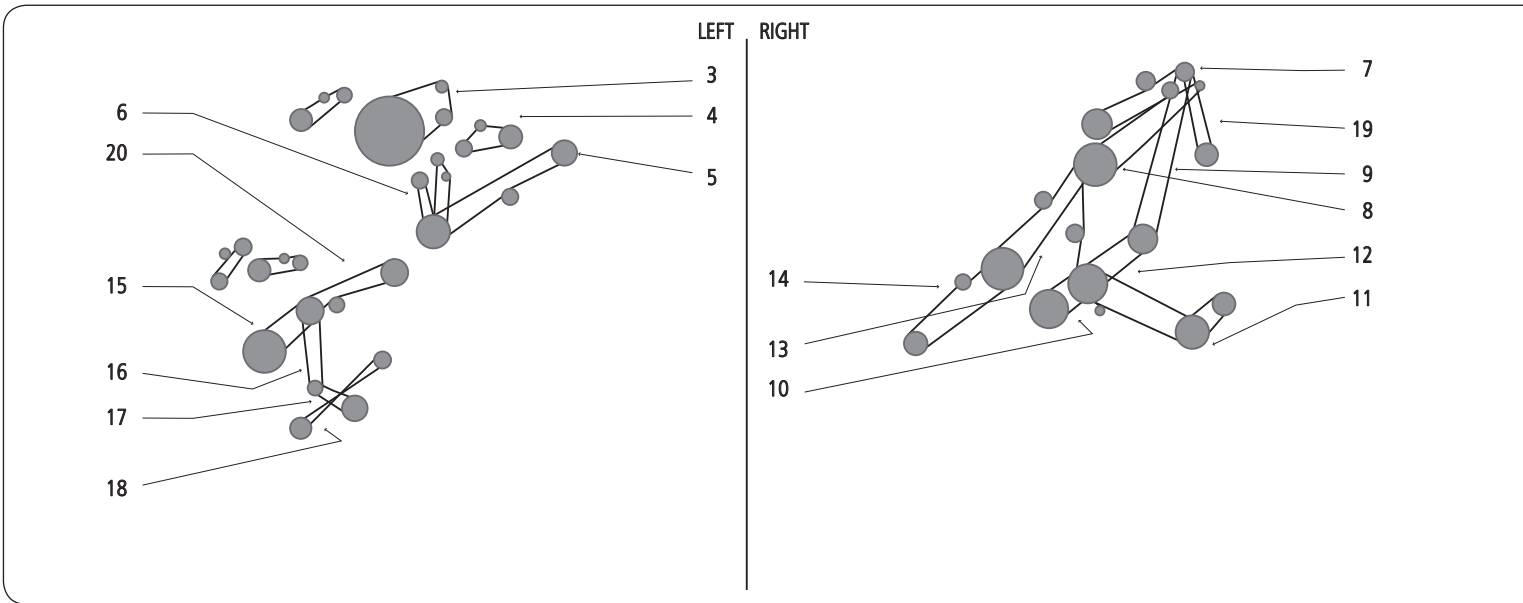

ITEM	APPLICATION	QUANTITY OF V-BELTS IN DRIVE	OE PART NUMBER	COMMENT
1		1	89838606	
2		1	80824182	X
3		1	80825117	
4	STRAW ELEVATOR - BEATER SHAFT	1	80424563	
5		1	80825013	
7		1	80330715	
8		1	89575153	
9		1	80755808	X
10		1	80753053	
11		1	80824176	
12		1	80724518	X
13		1	80824175	X
14		1	89575059	
15	BEATER SHAFT	1	89515075	
16	FAN	1	89515076	
17		1	80387460	X
18	STRAW WALKERS - ECCENTRIC SHAFT	1	80431784	

X - not in standard offer

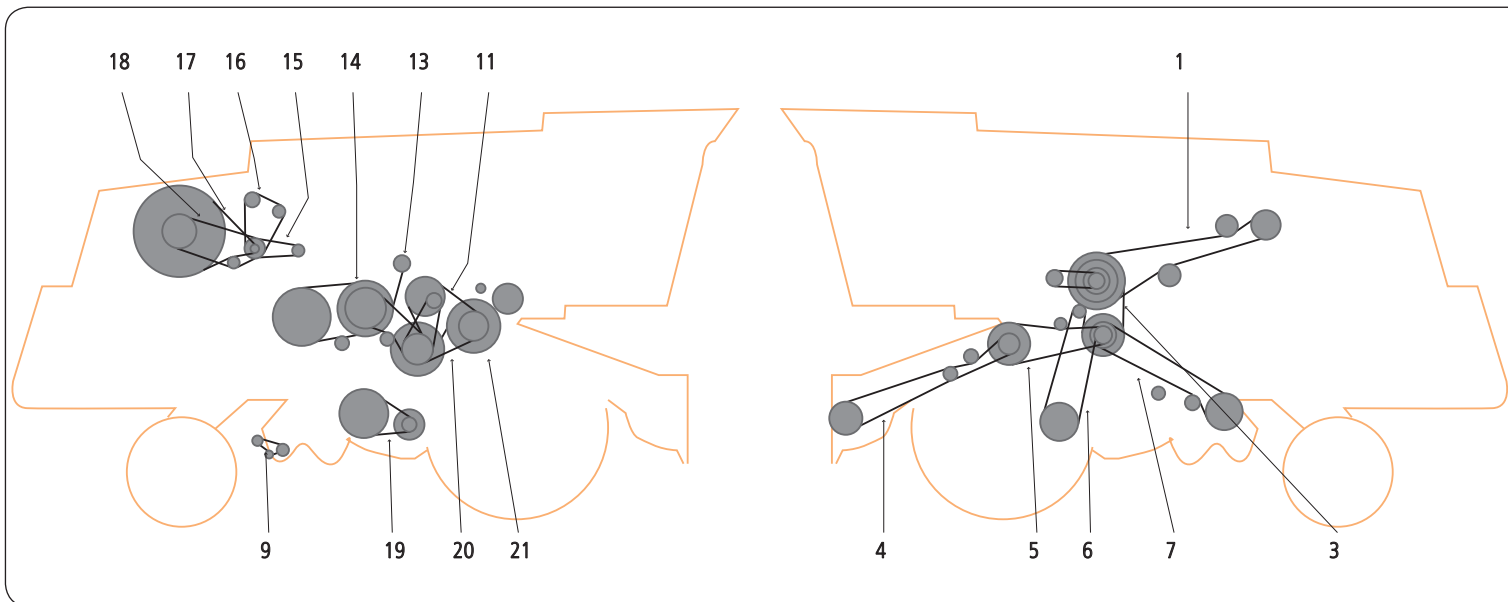

ITEM	APPLICATION	QUANTITY OF V-BELTS IN DRIVE	OE PART NUMBER	COMMENT
1	ENGINE TO BEATER SHAFT	1	80434044	
2	BEATER TO GRAIN TANK INTERMEDIATE SHAFT	1	80445640	
3	BEATER TO INTERMEDIATE SHAFT (FIAT ENGINE)	1	80434045	
3	BEATER TO INTERMEDIATE SHAFT (MERCEDES ENGINE)	1	80455865	
4	STRAW ELEVATOR DRIVE	1	80433746	
5	BEATER TO STRAW ELEVATOR	1	80434222	
5	BEATER TO STRAW ELEVATOR	1	80350236	
5	BEATER TO STRAW ELEVATOR	1	80743877	
6	GROUND SPEED VARIATOR	1	80440780	
7	SHAKER SHOE DRIVE	1	80448794	
11	REAR BEATER TO DRUM SHAFT	1	80186347	
13	INTERMEDIATE SHAFT TO ROTARY SEPARATOR	1	80434047	
14	ROTARY SEPARATOR TO ROTOR	1	80434046	
15	AIR CONDITIONING	1	80381237	
16	AIFO ENGINE	1	80449380	
16	MERCEDES ENGINE	1	80432642	
17	DUST CAP	1	80439495	
18	FAN DRIVE	1	80439496	
19	FAN DRIVE	1	80439832	
20	DRUM SHAFT TO INTERMEDIATE SHAFT	1	80434160	
21	INTERMEDIATE SHAFT TO GRAIN ELEVATOR	1	80433639	

X - not in standard offer

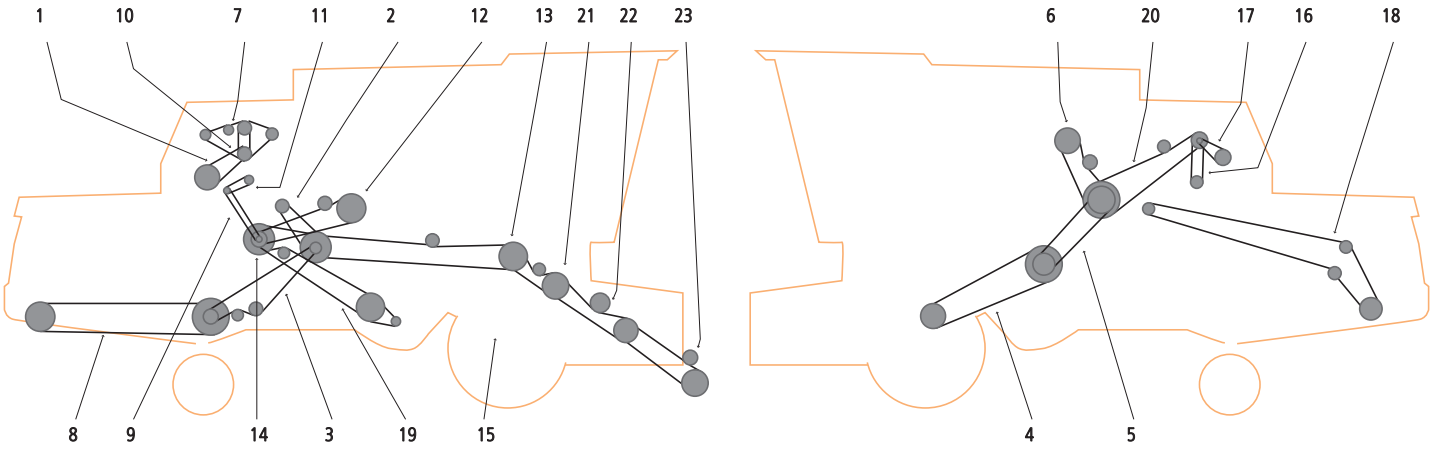

ITEM	APPLICATION	QUANTITY OF V-BELTS IN DRIVE	OE PART NUMBER	COMMENT
1	HYDRAULIC PUMP DRIVE (W/CAT)	1	248332	
1	HYDRAULIC PUMP DRIVE (FORD)	1	576772	
2	ROTARY VARI-DRIVE	1	717700	X
2	ROTARY VARI-DRIVE. HIGH SPEED ROTOR	1	637783	X
2	ROTOR VARI-DRIVE. STANDARD ROTOR	1	640143	X
3	STRAW CHOPPER. FRONT	1	619748	
4	TRACTION HYDRO DRIVE. LOWER	1	716414	
4	TRACTION HYDRO DRIVE. LOWER	1	634042	
4	TRACTION HYDRO DRIVE. LOWER	1	636645	
5	TRACTION HYDROSTATIC DRIVE. UPPER	1	716416	
5	STANDARD TRACTION. VARI-DRIVE. UPPER	1	717700	X
5	STANDARD TRACTION. VARI-DRIVE. UPPER	1	254093	
6	UNLOADING AUGER DRIVE	1	247782	
7	ENGINE FAN (W/CAT)	1	647901	X
7	ENGINE FAN (FORD)	1	772654	X
8	STRAW CHOPPER. REAR	1	614040	
9	ROTARY SCREEN. LOWER 65.75	1	610767	
9	ROTARY SCREEN. LOWER 68.3	1	612305	
10	WATER PUMP AND ALTERNATOR	1	772656	X
11	ROTARY SCREEN. UPPER	1	716254	X
12	CLEAN GRAIN ELEVATOR DRIVE	1	703747	
13	HEADER DRIVE. 167-9/32	1	246980	
13	HEADER DRIVE. 193	1	682008	X
14	DISCHARGE BEATER	1	621104	
15	CLEANING FAN. VARI-DRIVE 46 SLOW DO	1	624398	X
15	CLEANING FAN. VARI-DRIVE 58 STANDARD	1	642569	X
16	HYDROSTATIC CHARGE PUMP	1	259477	
17	AIR COMPRESSOR. 48	1	259346	X
17	AIR COMPRESSOR. 52.75	1	264557	
17	AIR COMPRESSOR. 54.5	1	576776	
18	STRAW CHOPPER DRIVE	1	246727	
18	STRAW CHOPPER DRIVE	1	230143	
19	SHAKER SHOE DRIVE	1	785415	
20	MAIN SHAFT DRIVE. STANDARD TRACTION	1	795009	X
20	MAIN SHAFT DRIVE	1	576771	
21	FEEDER DRIVE	1	620944	
22	FIXED SPEED FEEDER DRIVE	1	621367	
22	VARIABLE SPEED FEEDER DRIVE	1	630010	
23	VARIABLE SPEED FEEDER DRIVE	1	699368	X
23	VARIABLE SPEED FEEDER DRIVE	1	632890	

X - not in standard offer

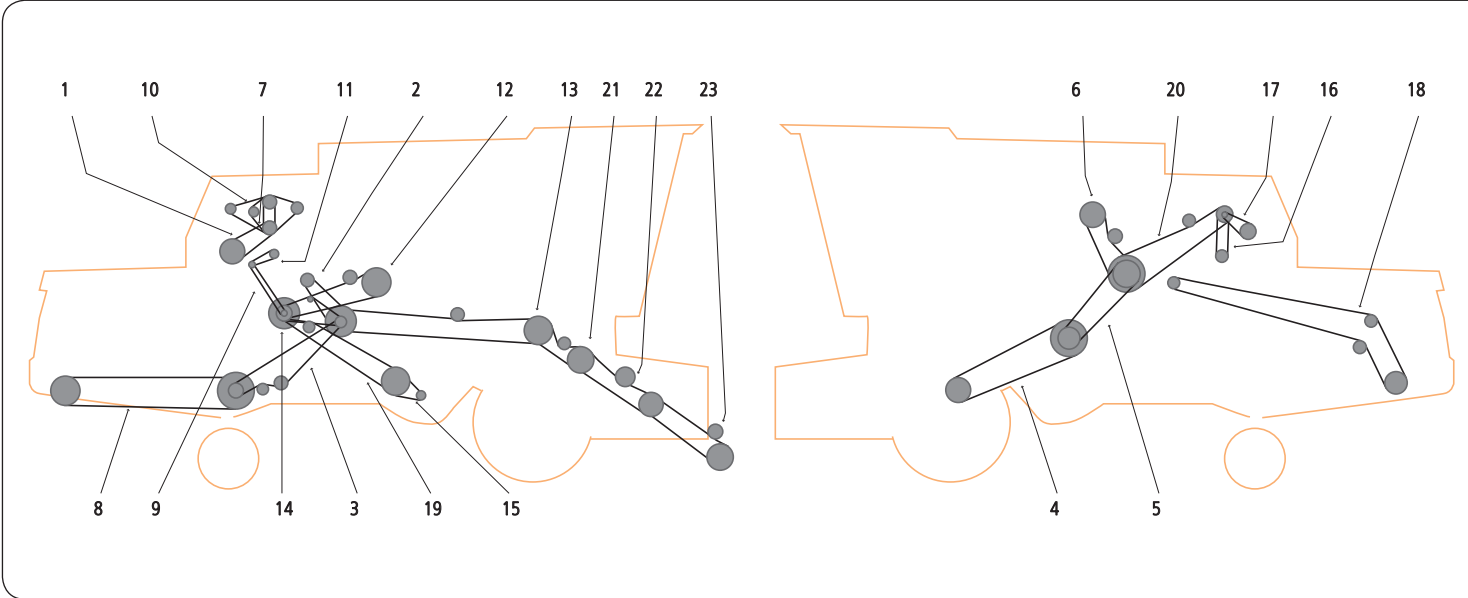

ITEM	APPLICATION	QUANTITY OF V-BELTS IN DRIVE	OE PART NUMBER	COMMENT
2	ROTARY VARI-DRIVE. HIGH SPEED ROTOR	1	637783	X
2	ROTARY VARI-DRIVE	1	717700	X
2	ROTOR VARI-DRIVE. STANDARD ROTOR	1	640143	X
3	STRAW CHOPPER. FRONT	1	619748	
4	TRACTION HYDRO DRIVE. LOWER	1	716414	
4	TRACTION HYDRO DRIVE. LOWER	1	634042	
4	TRACTION HYDRO DRIVE. LOWER	1	636645	
5	TRACTION HYDROSTATIC DRIVE. UPPER	1	716416	
5	STANDARD TRACTION. VARI-DRIVE. UPPER	1	717700	X
5	STANDARD TRACTION. VARI-DRIVE. UPPER	1	254093	
6	UNLOADING AUGER DRIVE	1	247782	
7	ENGINE FAN (W/CAT)	1	647901	X
7	ENGINE FAN (FORD)	1	772654	X
8	STRAW CHOPPER. REAR	1	614040	
9	ROTARY SCREEN. LOWER 65.75	1	610767	
9	ROTARY SCREEN. LOWER 68.3	1	612305	
11	ROTARY SCREEN. UPPER	1	716254	X
12	CLEAN GRAIN ELEVATOR DRIVE	1	703747	
13	HEADER DRIVE. 167-9/32	1	246980	
13	HEADER DRIVE. 193	1	682008	X
14	DISCHARGE BEATER	1	621104	
15	CLEANING FAN. VARI-DRIVE 46 SLOW DO	1	624398	X
15	CLEANING FAN. VARI-DRIVE 58 STANDARD	1	642569	X
16	HYDROSTATIC CHARGE PUMP	1	259477	
17	AIR COMPRESSOR. 48	1	259346	X
17	AIR COMPRESSOR. 52.75	1	264557	
17	AIR COMPRESSOR. 54.5	1	576776	
18	STRAW CHOPPER DRIVE	1	246727	
18	STRAW SPREADER DRIVE	1	230143	
19	SHAKER SHOE DRIVE	1	785415	
20	MAIN SHAFT DRIVE. STANDARD TRACTION	1	795009	X
20	MAIN SHAFT DRIVE	1	246978	
21	FEEDER DRIVE	1	620944	
22	FIXED SPEED FEEDER DRIVE	1	621367	
22	VARIABLE SPEED FEEDER DRIVE	1	630010	
23	VARIABLE SPEED FEEDER DRIVE	1	699368	X
23	VARIABLE SPEED FEEDER DRIVE	1	632890	

X - not in standard offer

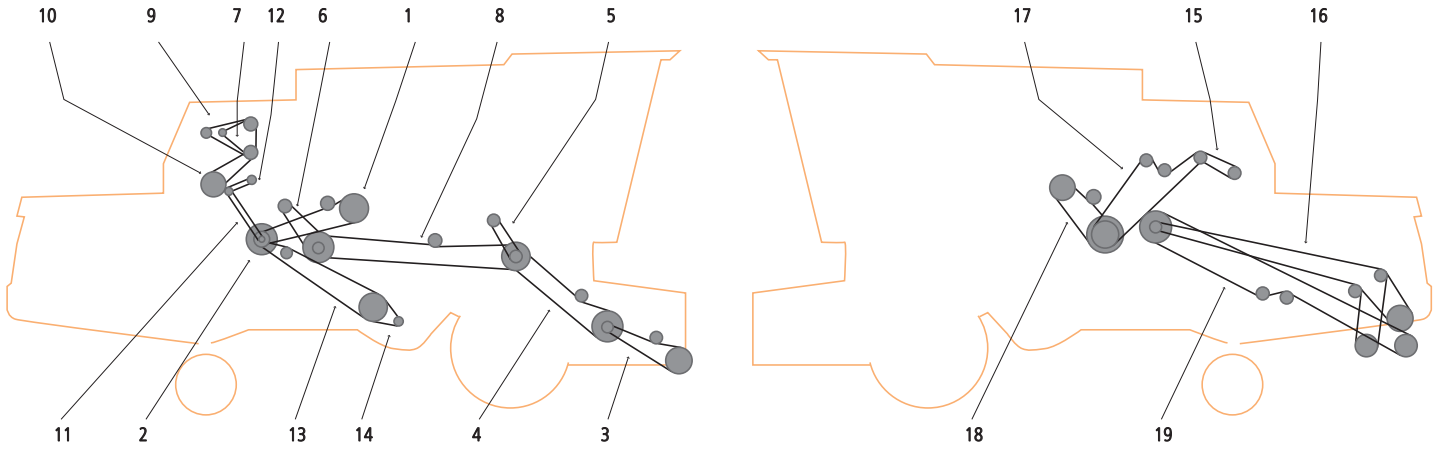

ITEM	APPLICATION	QUANTITY OF V-BELTS IN DRIVE	OE PART NUMBER	COMMENT
1	CLEAN GRAIN ELEVATOR DRIVE	1	703747	
2	DISCHARGE BEATER DRIVE	1	617362	X
3	FEEDER DRIVE	1	699268	X
4	SMALL GRAIN SPECIAL	1	9613963	X
4	FIXED SPEED FEEDER DRIVE	1	621367	
4	VARI-SPEED FEEDER	1	849514	X
5	HYDRAULIC REEL DRIVE PUMP DRIVE	1	244025	
6	ROTOR VARI-DRIVE. HIGH SPEED	1	637783	X
6	ROTOR VARI-DRIVE. STANDARD	1	640143	X
7	ENGINE FAN. HYDRAULIC PUMP. SET OF 2	1	855676	X
7	ENGINE FAN. SET OF 2	1	647901	X
8	HEADER DRIVE	1	682008	X
9	ALTERNATOR. SET OF 2	1	572981	X
9	ALTERNATOR. SET OF 2	1	626654	
10	HYDRAULIC PUMP. SET OF 2	1	855676	X
10	HYDRAULIC PUMP. SET OF 2	1	248332	
11	ROTARY SCREEN DRIVE (PRIMARY)	1	610767	
11	ROTARY SCREEN DRIVE (PRIMARY)	1	612305	
12	ROTARY SCREEN (SECONDARY)	1	716254	X
13	SHAKER SHOE DRIVE	1	785415	
14	CLEANING FAN. VARI-DRIVE 52	1		
14	CLEANING FAN. VARI-DRIVE 58 STANDARD	1	792809	X
15	AIR CONDITIONING COMPRESSOR	1	259346	X
15	AIR CONDITIONING COMPRESSOR	1	577240	X
16	STRAW SPREADER DRIVE	1	230143	
17	MAIN SHAFT DRIVE. HYDROSTATIC	1	797978	
17	MAIN SHAFT DRIVE. HYDROSTATIC	1	788803	X
18	UNLOADING AUGER DRIVE	1	694982	X
19	STRAW CHOPPER DRIVE	1	618853	

X - not in standard offer

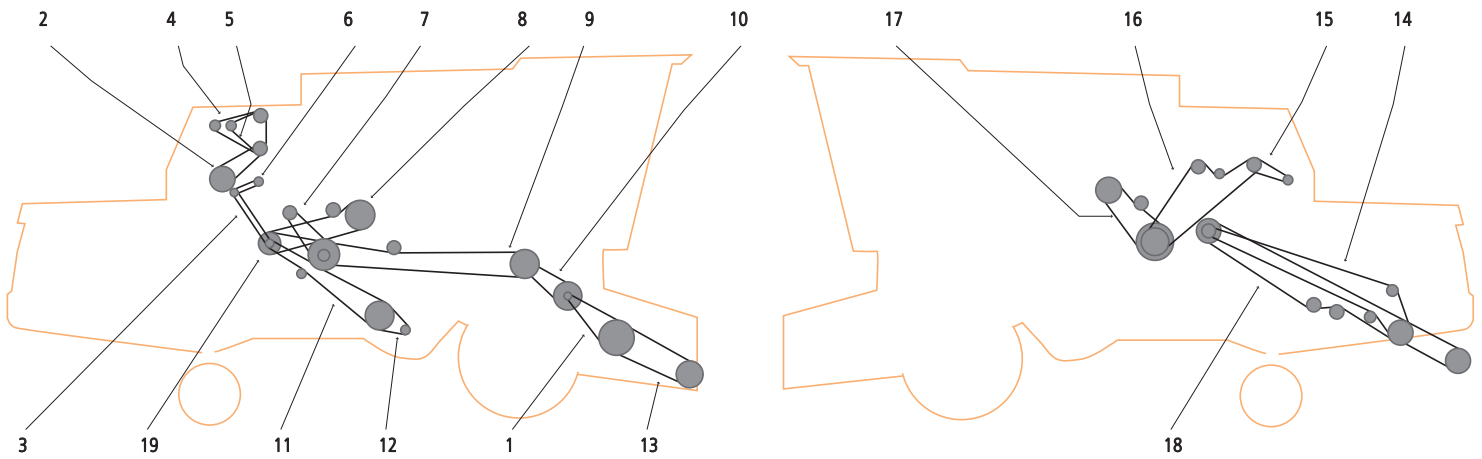

ITEM	APPLICATION	QUANTITY OF V-BELTS IN DRIVE	OE PART NUMBER	COMMENT
1	FIXED SPEED FEEDER	1	621367	
1	VARI SPEED FEEDER	1	630010	
2	HYDRAULIC PUMP	1	624650	
3	ROTARY SCREEN DRIVE	1	615790	
4	ALTERNATOR. WATER PUMP DRIVE	1	626654	
5	ENGINE FAN DRIVE	1	758340	X
6	ALTERNATOR. SET OF 2	1	626657	X
6	ROTARY SCREEN SECONDARY DRIVE	1	716254	X
7	ROTOR DRIVE	1	692974	X
7	ROTOR DRIVE	1	692975	X
7	ROTOR DRIVE	1	787583	X
8	CLEAN GRAIN ELEVATOR DRIVE	1	230164	
9	HEADER DRIVE	1	246980	
9	ROTOR. VARI-DRIVE. HIGH SPEED	1	692975	X
10	FEEDER DRIVE. SET OF 3	1	620944	
11	SHAKER SHOE DRIVE	1	774747	X
12	CLEANING FAN. VARI-DRIVE	1	710751	X
12	CLEANING FAN. VARI-DRIVE W/SLOW DOWN	1	710752	X
12	CLEANING FAN. VARI-DRIVE W/INT.SPD KIT	1	773300	X
13	STONEROLL DRIVE. SET OF 5	1	632890	
14	STRAW CHOPPER BEATER DRIVE	1	230143	
15	AIR CONDITIONING COMPRESSOR 48	1	259346	X
15	AIR CONDITIONING COMPRESSOR 52.75	1	264557	
16	MAIN SHAFT AND HYDROSTATIC PUMP DRIVE	1	649035	X
16	MAIN SHAFT AND HYDROSTATIC PUMP DRIVE	1	638337	X
17	UNLOADING AUGER DRIVE	1	618805	
18	STRAW SPREADER	1	618040	

X - not in standard offer

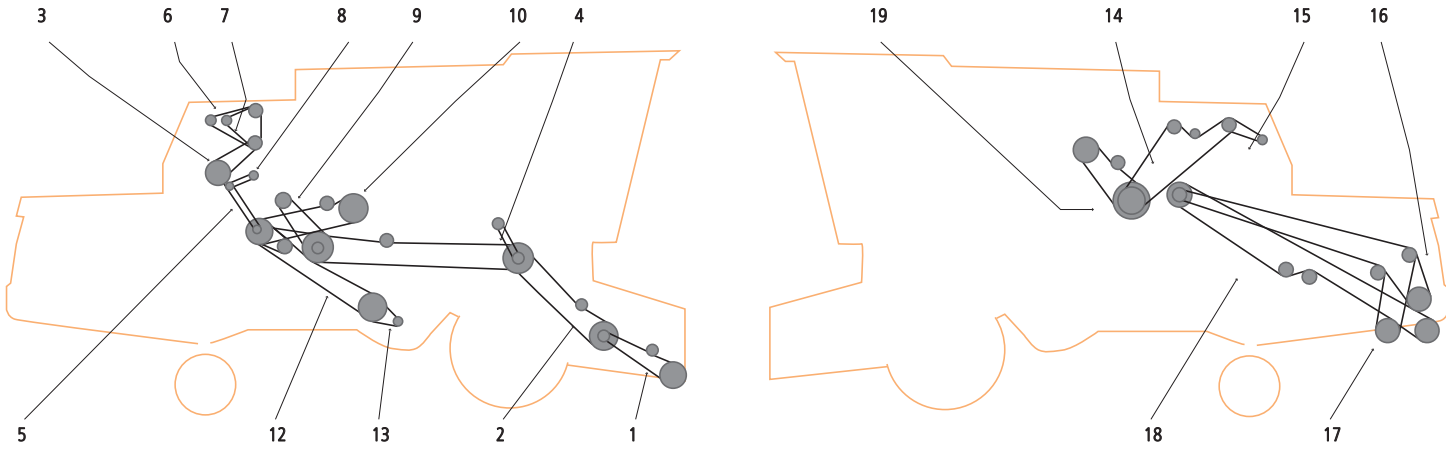

ITEM	APPLICATION	QUANTITY OF V-BELTS IN DRIVE	OE PART NUMBER	COMMENT
1	FEEDER DRIVE	1	699268	X
2	SMALL GRAIN SPECIAL. 3HB	1	9613963	X
2	FIXED SPEED FEEDER DRIVE	1	621367	
2	VARI-SPEED FEEDER DRIVE	1	849514	X
2	VARI-SPEED FEEDER DRIVE	1	9601511	X
3	ENGINE FAN AND HYDRAULIC PUMP	1	855676	X
3	HYDRAULIC PUMP	1	624650	
3	ENGINE FAN	1	768340	X
4	HYDRAULIC PUMP DRIVE	1	244025	
5	ROTARY SCREEN DRIVE PRIMARY	1	615790	
5	ROTARY SCREEN DRIVE PRIMARY	1	859063	X
6	ALTERNATOR. SET OF 2	1	572981	X
6	ALTERNATOR. SET OF 2	1	626654	
6	ALTERNATOR. SET OF 2	1	626657	X
7	WATER PUMP DRIVE	1	592711	X
8	ROTARY SCREEN (SECONDARY)	1	716254	X
9	ROTOR. VARI-DRIVE. STANDARD	1	692974	X
9	ROTOR. VARI-DRIVE. HIGH SPEED	1	692975	X
10	CLEAN GRAIN ELEVATOR DRIVE (IMPROVED)	1	9604713	X
10	CLEAN GRAIN ELEVATOR DRIVE	1	230164	
11	HEADER DRIVE	1	682008	X
12	SHAKER SHOE DRIVE	1	774747	X
13	CLEAN FAN. VARI-DRIVE 61.6 INT SPE	1	773300	X
13	CLEAN FAN. VARI-DRIVE 69.5 HIGH SPE	1	792811	X
14	MAIN SHAFT DRIVE. HYDROSTATIC	1	649035	X
14	MAIN SHAFT DRIVE. HYDROSTATIC	1	797979	X
15	AIR CONDITIONING COMPRESSOR	1	259346	X
15	AIR CONDITIONING COMPRESSOR	1	626657	X
16	STRAW SPREADER DRIVE	1	618040	
17	STRAW CHOPPER. INFEED DRUM DRIVE	1	230143	
18	STRAW CHOPPER DRIVE	1	618853	
19	UNLOADING AUGER DRIVE	1	618805	

X - not in standard offer

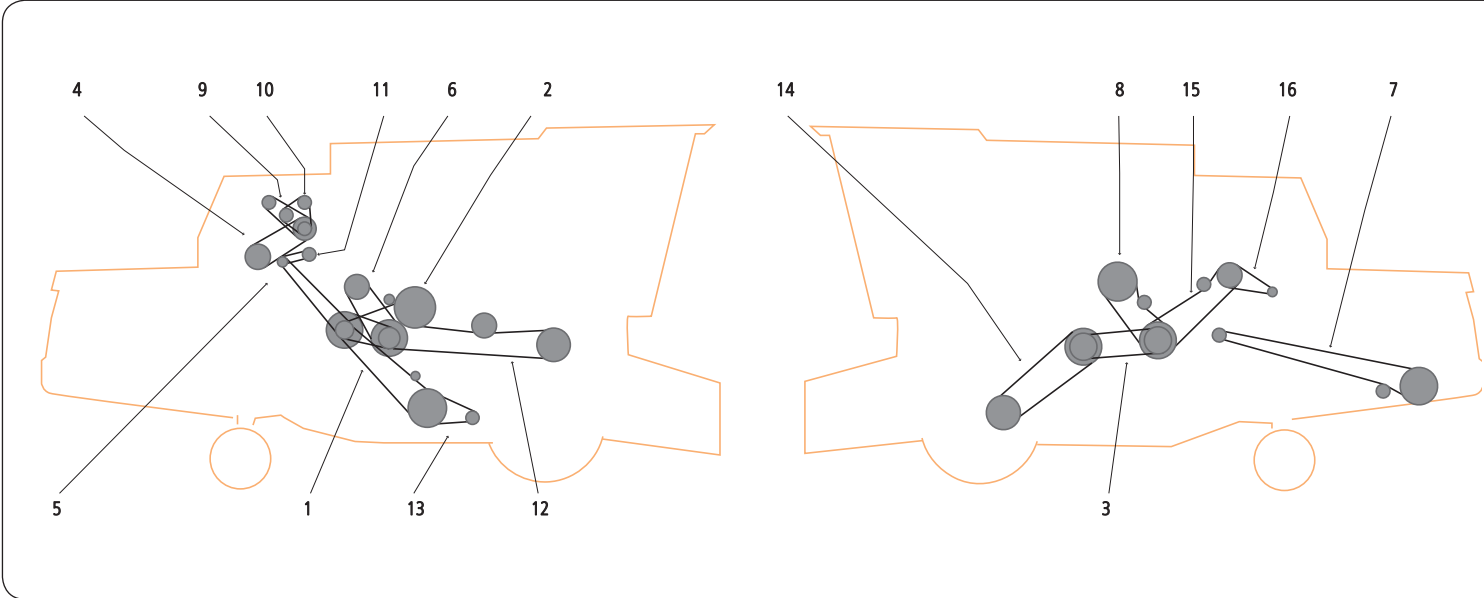

ITEM	APPLICATION	QUANTITY OF V-BELTS IN DRIVE	OE PART NUMBER	COMMENT
1	BEATER DRIVE	1	621104	
2	GRAIN ELEVATOR DRIVE	1	703747	
3	GROUND SPEED VARI-DRIVE	1	261000	X
4	HYDRAULIC PUMP DRIVE (GAS AND CAT DIESEL)	1	248332	
4	HYDRAULIC PUMP DRIVE (FORD DIESEL ENGINE)	1	576772	
5	ROTARY SCREEN. JACKSHAFT DRIVE	1	246771	
6	ROTOR DRIVE	1	254093	
6	ROTOR DRIVE (OPT FOR HIGH SPEED)	1	715785	X
7	STRAW CHOPPER DRIVE	1	578206	
7	STRAW SPREADER	1	246727	
7	STRAW SPREADER	1	230143	
8	UNLOADING AUGER DRIVE	1	247782	
9	GOVERNOR (GAS ENGINE)	1	266209	
10	FAN AND ALTERNATOR (CAT DIESEL)	1	254084	
10	FAN AND ALTERNATOR (GAS)	1	261472	X
10	FAN AND ALTERNATOR (FORD DIESEL)	1	576774	
10	FAN AND ALTERNATOR (CAT DIESEL)	1	626654	
11	ROTARY SCREEN DRIVE	1	126805	X
12	HEADER DRIVE	1	246980	
13	CLEANING FAN DRIVE	1	284521	X
14	GROUND SPEED. HYDRO DRIVE	1	268612	
14	GROUND SPEED. VARI-DRIVE	1	261001	
15	MAIN DRIVE. POWER BAND (GAS AND CAT DIESEL)	1	246978	
15	MAIN DRIVE. POWER BAND (FORD DIESEL)	1	576771	
16	AIR CONDITIONING (GAS AND CAT DIESEL)	1	264557	
16	AIR CONDITIONING (FORD DIESEL)	1	576776	

X - not in standard offer

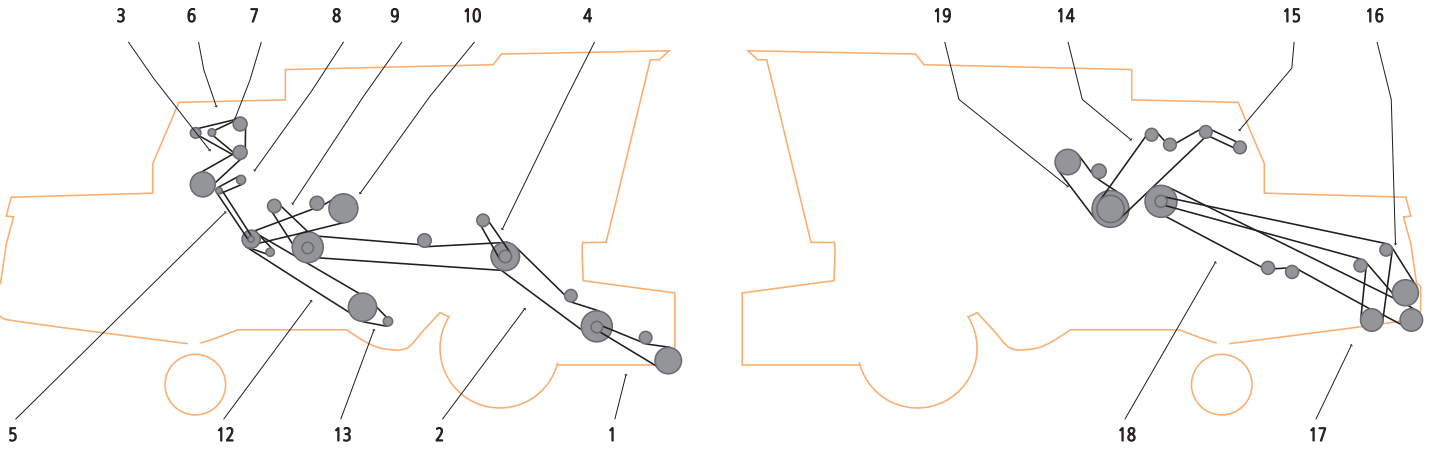

ITEM	APPLICATION	QUANTITY OF V-BELTS IN DRIVE	OE PART NUMBER	COMMENT
1	ENGINE FAN. HYDRAULIC PUMP (SET OF 2)	1	855676	X
2	ALTERNATOR. SET OF 2	1	572981	X
3	WATER PUMP DRIVE (FORD)	1	592711	X
4	ROTOR. VARI-DRIVE. STANDARD	1	692974	X
4	ROTOR. VARI-DRIVE. HIGH SPEED	1	692975	X
5	DISCHARGE BEATER	1	709806	
6	CLEAN GRAIN ELEVATOR DRIVE	1	230164	
6	CLEAN GRAIN ELEVATOR DRIVE IMPROVED	1	9604713	
7	HEADER DRIVE	1	682008	
8	HYDRAULIC REEL DRIVE PUMP	1	9609607	
9	ROTARY SCREEN DRIVE (PRIMARY)	1	859063	X
10	SHAKER SHOE DRIVE	1	774747	
12	FEEDER. DRIVE. BANDED	1	699268	X
13	FIXED SPEED FEEDER. SET OF 2	1	621367	
14	VARI-SPEED FEEDER	1	9601511	X
15	MAIN SHAFT DRIVE. HYDROSTATIC. BANDED	1	797979	X
16	AIR CONDITIONING COMPRESSOR	1	626657	X
17	STRAW SPREADER DRIVE	1	618040	
18	STRAW CHOPPER DRIVE	1	618853	
19	STRAW CHOPPER. INFEED DRUM DRIVE	1	230143	
20	UNLOADING AUGER DRIVE	1	618805	

X - not in standard offer

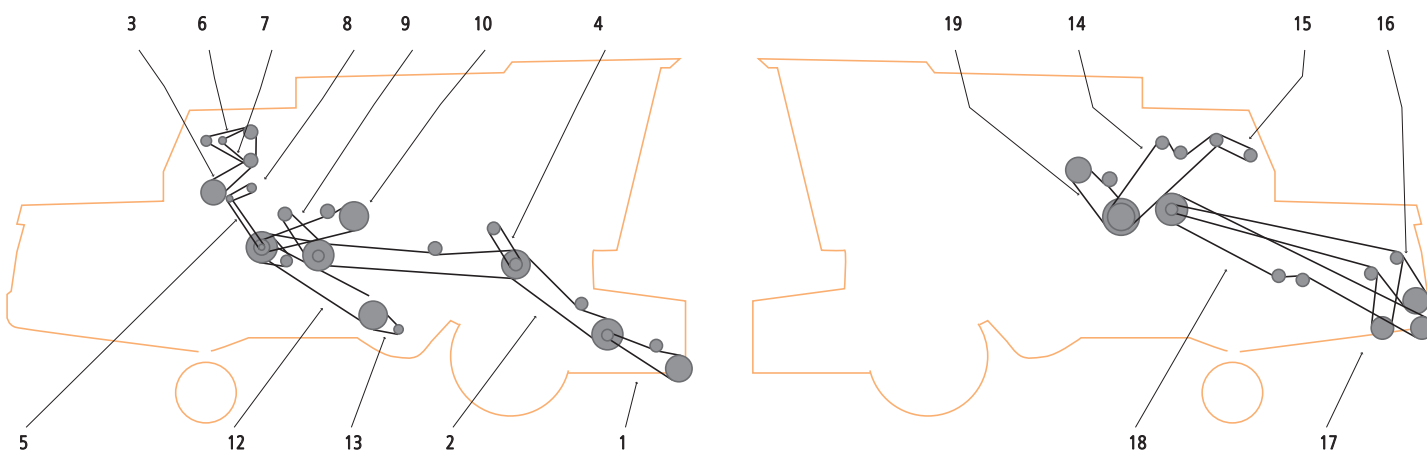

ITEM	APPLICATION	QUANTITY OF V-BELTS IN DRIVE	OE PART NUMBER	COMMENT
1	HYDRAULIC PUMP (SET OF 2)	1	773255	X
2	ALTERNATOR	1	86513664	X
3	WATER PUMP DRIVE	1	8652069	X
4	ROTOR. VARI-DRIVE. STANDARD	1	86518568	X
4	ROTOR. VARI-DRIVE. HIGH SPEED	1	86518659	X
5	DISCHARGE BEATER	1	86520042	
6	CLEAN GRAIN ELEVATOR DRIVE	1	230164	
6	CLEAN GRAIN ELEVATOR DRIVE IMPROVED	1	9604713	
7	HEADER DRIVE	1	86503087	X
8	HYDRAULIC REEL DRIVE PUMP	1	9609607	
9	ROTARY SCREEN DRIVE (PRIMARY)	1	859063	X
10	SHAKER SHOE DRIVE	1	774747	
12	FEEDER. DRIVE. BANDED	1	699268	X
13	FIXED SPEED FEEDER	1	9613963	
14	VARI-SPEED FEEDER	1	9601511	X
15	MAIN SHAFT DRIVE. HYDROSTATIC. BANDED	1	86514163	X
16	AIR CONDITIONING COMPRESSOR	1	577240	X
17	STRAW SPREADER DRIVE	1	618040	
18	STRAW CHOPPER DRIVE	1	618853	
19	STRAW CHOPPER. INFEED DRUM DRIVE	1	230143	
20	UNLOADING AUGER DRIVE	1	86514256	X

X - not in standard offer

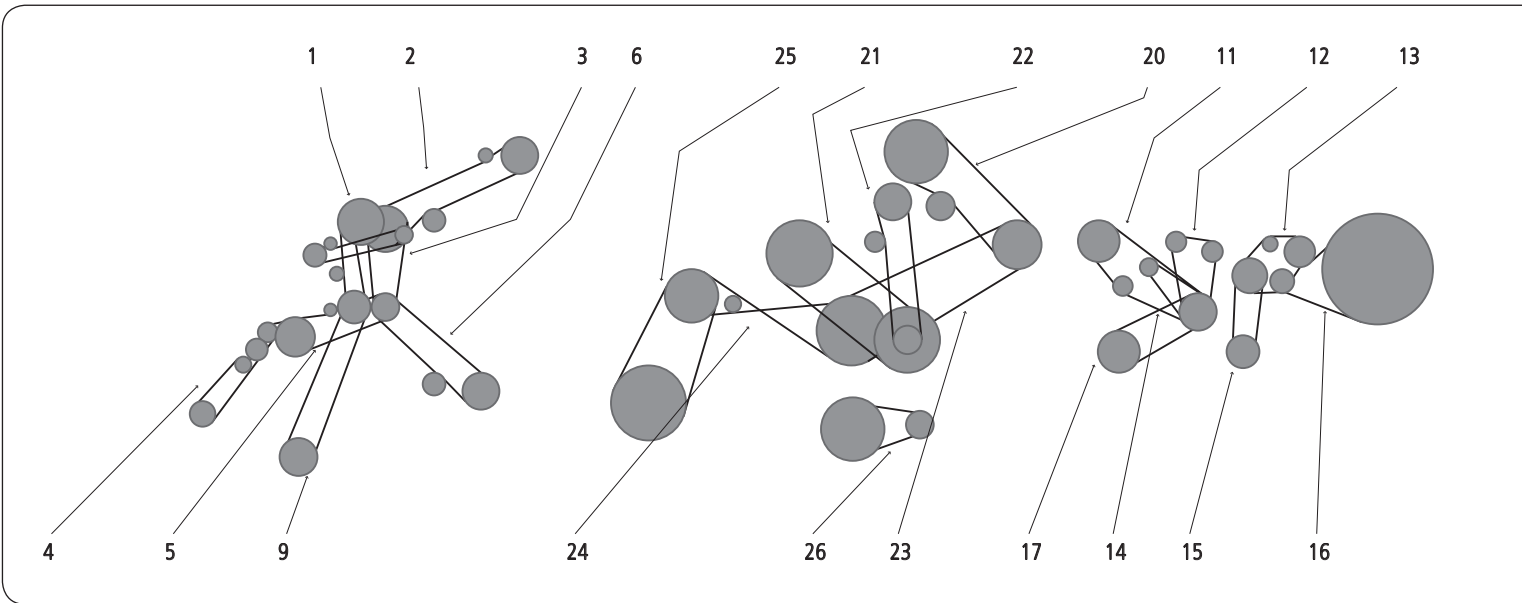

ITEM	APPLICATION	QUANTITY OF V-BELTS IN DRIVE	OE PART NUMBER	COMMENT
1	BEATER TO INTERMEDIATE DRIVE	1	80455865	
2	ENGINE TO BEATER SHAFT - HYDROSTATIC DRIVE	1	80922872	
2	ENGINE TO BEATER SHAFT - MECHANICAL DRIVE	1	80922911	
3	UNLOADING AUGER ENGAGING / CODE 100	1	80445640	
3	UNLOADING AUGER ENGAGING	1	89512971	
4	STRAW ELEVATOR	1	80433746	
5	BEATER TO STRAW ELEVATOR	1	80350236	
6	CLEANING SHOE DRIVE BELT	1	80448794	
9	GROUND SPEED VARIATOR	1	80440780	
11	COOLING FAN DRIVE - INTERMEDIATE SHAFT	1	80913151	
12	WATER PUMP DRIVE	1	80443634	
13	ROTARY DUST SCREEN DRIVE	1	80913153	X
14	ALTERNATOR DRIVE	1	89501182	X
15	COMPRESSOR DRIVE	1	89506748	X
16	DUST SCREEN BELT	1	80923019	
17	HYDRAULIC PUMP TO ENGINE	1	89508558	
20	BEATER DRIVE BELT	1	89513984	
21	ROTARY SEPARATOR DRIVE BELT	1	80754285	
22	GRAIN STORAGE DRIVE	1	80433639	
23	DRUM TO INTERMEDIATE DRIVE	1	80434160	
24	STRAW WALKER INTERMEDIATE SHAFT DRIVE	1	80754389	
25	STRAW WALKER DRIVE BELT	1	80754388	
26	CLEANING FAN VARI - DRIVE BELT	1	89502654	

X - not in standard offer

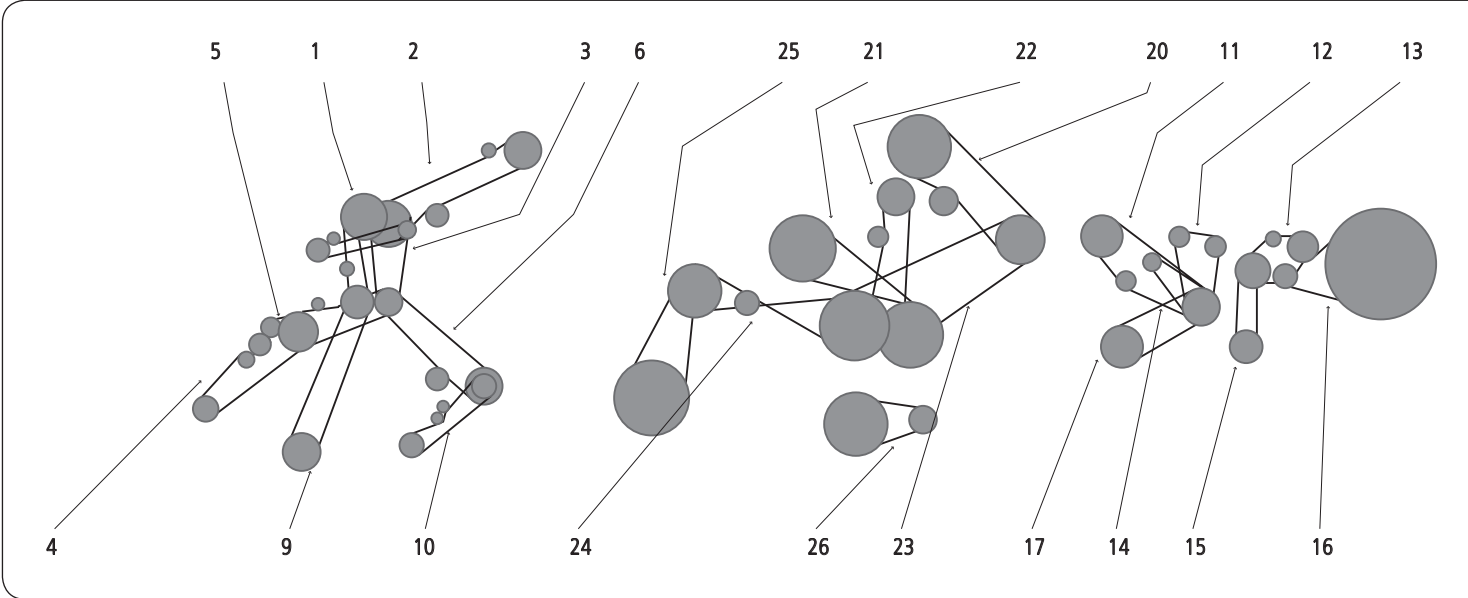

ITEM	APPLICATION	QUANTITY OF V-BELTS IN DRIVE	OE PART NUMBER	COMMENT
1	BEATER TO INTERMEDIATE DRIVE	1	80455865	
2	ENGINE TO BEATER SHAFT - HYDROSTAT DRIVE	1	80922872	
2	ENGINE TO BEATER SHAFT - MECHANICAL DRIVE	1	80922911	
3	UNLOADING AUGER ENGAGING / CODE 129	1	80445640	
3	UNLOADING AUGER ENGAGING	1	89512971	
4	STRAW ELEVATOR SIDE	1	80433746	
4	STRAW ELEVATOR SIDE	1	80454990	
5	BEATER TO STRAW ELEVATOR	1	80434222	
5	BEATER TO STRAW ELEVATOR	1	80350236	
6	CLEANING SHOE DRIVE BELT / FIXED SHOE	1	80446780	
6	CLEANING SHOE DRIVE BELT / SELF-LEVELLING	1	80448794	
9	GROUND SPEED VARIATOR	1	80440780	
10	ECCENTRIC SHAFT DRIVE / FIXED SHOE ONLY	1	80230164	
11	COOLING FAN DRIVE - INTERMEDIATE SHAFT	1	80913151	
12	WATER PUMP DRIVE	1	80443634	
13	ROTARY DUST SCREEN DRIVE	1	80913153	X
14	ALTERNATOR DRIVE	1	89501182	X
15	COMPRESSOR DRIVE	1	89506748	X
16	DUST SCREEN DRIVE	1	80923019	
17	HYDRAULIC PUMP TO ENGINE	1	89508558	
20	BEATER DRIVE BELT / CODE 124	1	80186347	
0	BEATER DRIVE BELT / CODE 123	1	89513984	
21	ROTARY SEPARATOR DRIVE BELT	1	80754285	
22	GRAIN STORAGE DRIVE	1	80433639	
23	DRUM TO INTERMEDIATE SHAFT	1	80434160	
24	STRAW WALKER INTERMEDIATE SHAFT DRIVE	1	80754389	
25	STRAW WALKER DRIVE BELT	1	80754388	
26	CLEANING FAN - CODE 111 / SELF-LEVELLING	1	89502654	
26	CLEANING FAN - CODE 111 / FIXED SHOE	1	80919739	X
26	CLEANING FAN - CODE 110 / SELF-LEVELLING	1	80439832	

X - not in standard offer

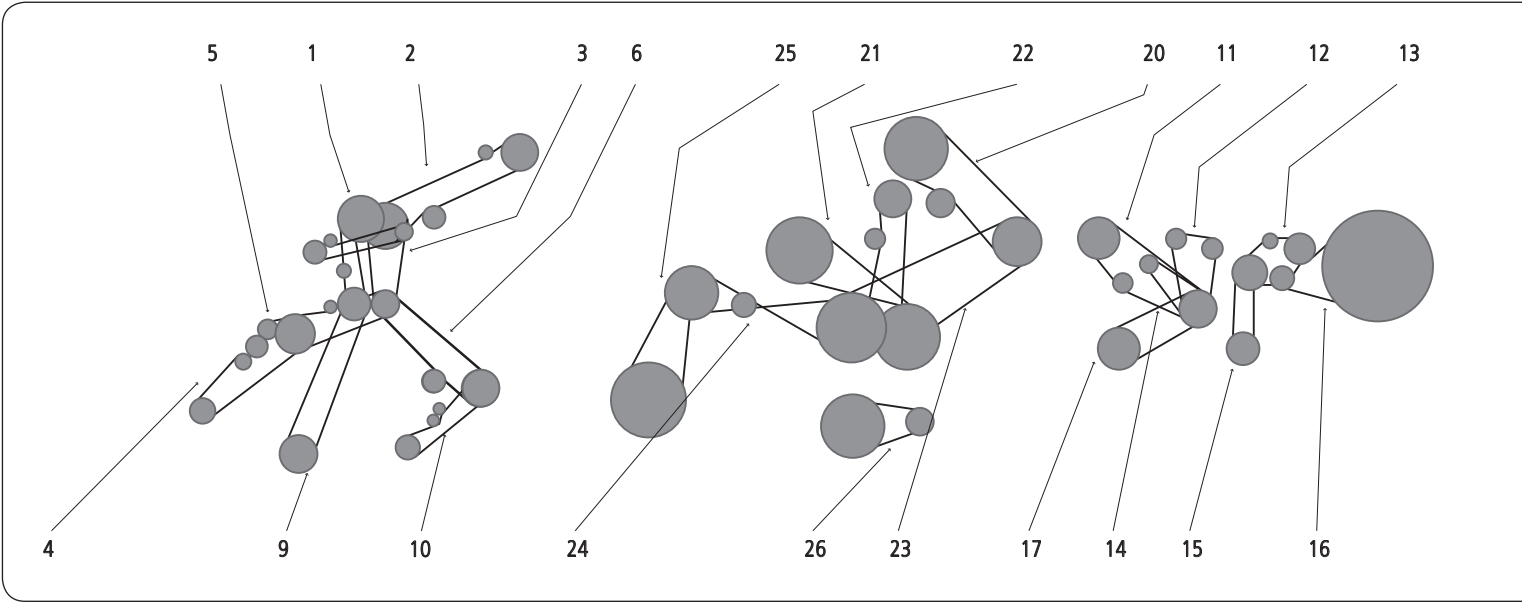

ITEM	APPLICATION	QUANTITY OF V-BELTS IN DRIVE	OE PART NUMBER	COMMENT
1	UNLOADING AUGER ENGAGING	1	80445640	
2	ENGINE TO BEATER SHAFT (HYDROSTATIC)	1	80922872	
2	ENGINE TO BEATER SHAFT (MECHANICAL)	1	80922911	
3	STRAW ELEVATOR DRIVE	1	80433746	
3	STRAW ELEVATOR DRIVE	1	80454990	
4	BEATER TO REINFORCED STRAW ELEVATOR	1	80350236	
4	BEATER TO STRAW ELEVATOR	1	80434222	
4	BEATER TO STRAW ELEVATOR	1	80743877	
5	GROUND SPEED VARIATOR	1	80440780	
6	BEATER TO INTERMEDIATE DRIVE	1	80455865	
7	CLEANING SHOE DRIVE BELT	1	80448794	
8		1	80923019	
9	WATER PUMP & ALTERNATOR DRIVE	1	89501863	X
10		1	80913153	X
11		1	80443634	
12		1	89501182	X
13	ROTARY SEPARATOR DRIVE BELT	1	80754285	
14		1	80434047	
15		1	80754165	X
16		1	80921698	X
17		1	80912771	X
18	STRAW WALKER DRIVE BELT	1	80754388	
19	STRAW WALKER INTERMEDIATE SHAFT DRIVE	1	80754389	
20	CLEANING FAN VARI-DRIVE BELT	1	80439832	
21	GRAIN STORAGE DRIVE	1	80433639	
22	DRUM TO INTERMEDIATE SHAFT	1	80434160	

X - not in standard offer

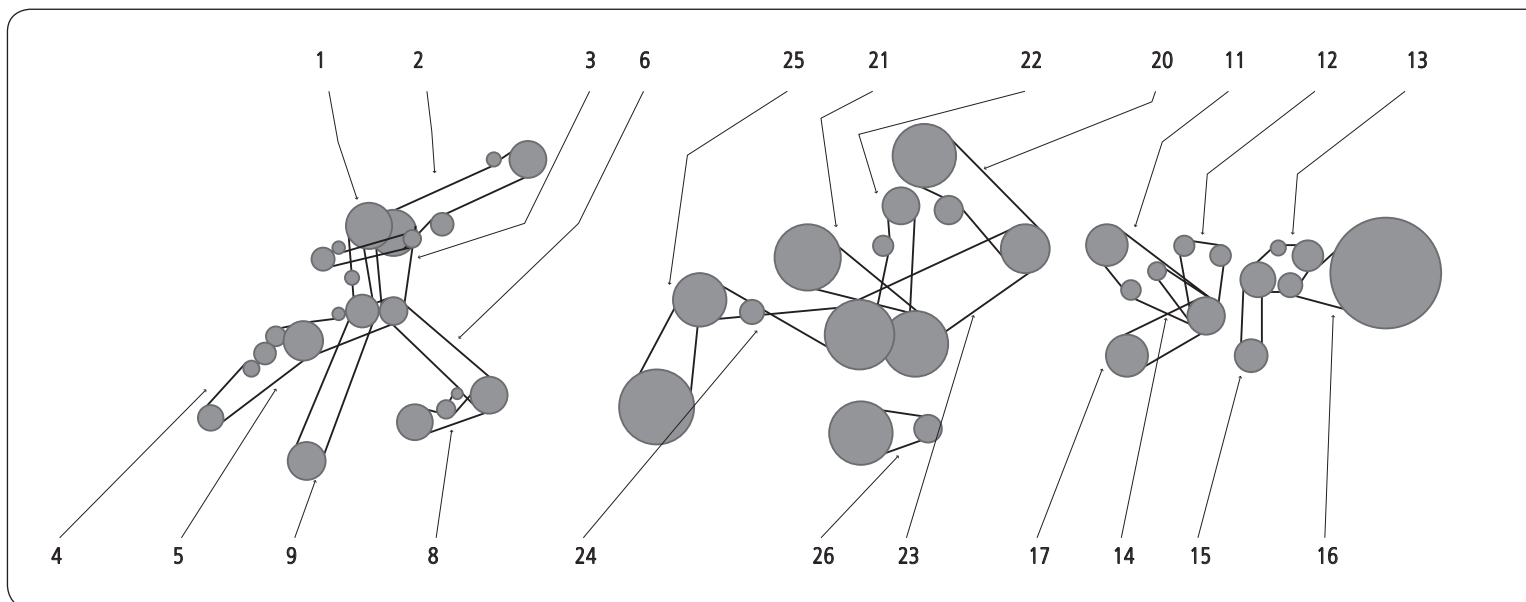

ITEM	APPLICATION	QUANTITY OF V-BELTS IN DRIVE	OE PART NUMBER	COMMENT
1	BEATER TO INTERMEDIATE DRIVE	1	80455865	
2	ENGINE TO BEATER SHAFT	1	80922872	
3	UNLOADING AUGER ENGAGING - CODE 130	1	80445640	
3	UNLOADING AUGER ENGAGING - CODE 129	1	89512971	
4	STRAW ELEVATOR SIDE	1	89504547	
4	STRAW ELEVATOR SIDE	1	89504005	
5	BEATER TO STRAW ELEVATOR	1	80434222	
5	BEATER TO STRAW ELEVATOR	1	80350236	
6	ECCENTRIC SHAFT - CODE 108 / BLOCKED FRAME	1	80230164	
6	CLEANING SHOE DRIVE BELT	1	80448794	
8	ECCENTRIC SHAFT - CODE 109 / BLOCKED FRAME	1	89513620	
11	COOLING FAN DRIVE - INTERMEDIATE SHAFT	1	80913151	
12	WATER PUMP DRIVE	1	80443634	
13	ROTARY DUST SCREEN DRIVE	1	80913153	X
14	ALTERNATOR DRIVE	1	89501182	X
15	COMPRESSOR DRIVE	1	89506748	X
16	DUST SCREEN DRIVE	1	80923019	
17	HYDRAULIC PUMP TO ENGINE	1	89508557	
20	BEATER DRIVE BELT - CODE 118	1	80186347	
20	BEATER DRIVE BELT - CODE 117	1	89513984	
21	ROTARY SEPARATOR DRIVE BELT	1	80754285	
22	GRAIN STORAGE DRIVE	1	80433639	
23	DRUM TO INTERMEDIATE SHAFT	1	80434160	
24	STRAW WALKER INTERMEDIATE SHAFT DRIVE	1	80754389	
25	STRAW WALKER DRIVE BELT	1	80754388	
26	CLEANING FAN VARI-DRIVE BELT	1	89502654	

X - not in standard offer

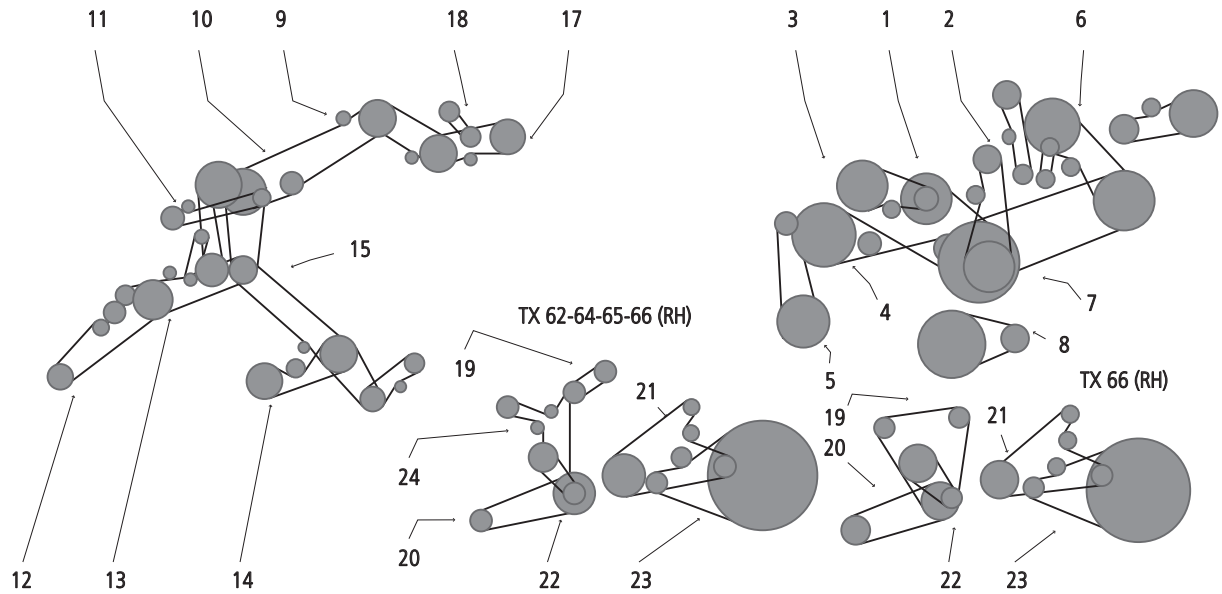

ITEM	APPLICATION	QUANTITY OF V-BELTS IN DRIVE	OE PART NUMBER	COMMENT
1		1	84015531	
1		1	89850770	
2		1	84015852	
3		1	84015852	
4		1	80754389	
5		1	80754388	
6		1	89513984	
7		1	80434160	
7		1	89832601	
8	GRAS SEED. (SELF LEVELLING)	1	84023277	X
8	(SELF LEVELLING)	1	89502654	
8	GRAS SEED. (FIXED SHOE) (BLOCKED FRAME)	1	84023278	X
9	I	1	80922911	X
9		1	89831571	
10		1	80455865	
11		1	89814069	
12	(WITH LATERAL FLOTATION) (4HB)	1	89593400	
12	(WITH LATERAL FLOTATION) (HC)	1	89593418	
12	(HC)	1	89593440	
12	(4HB)	1	89593464	
13	(2HB)	1	80434222	
13	(3HB)	1	89832309	
14	(BLOCKED FRAME)	1	89513620	
14	(FIXED SHOE)	1	80230164	
15	(BLOCKED FRAME)	1	80446780	
15	(FIXED SHOE)	1	80448794	
16	(SELF LEVELLING)	1	84005417	
16		1	84004444	
17	STRAW CHOPPER	1	84004443	
17	STRAW CHOPPER	1	84017621	
18	CHAFF SPREADER	1	84018864	
19		1	89835876	
19		1	80754165	X
19		1	84007307	
20		1	89839030	
20		1	89835816	
21		1	89833619	
21		1	89514311	
21		1	89817454	

ITEM	APPLICATION	QUANTITY OF V-BELTS IN DRIVE	OE PART NUMBER	COMMENT
21		1	89817959	
21		1	89850261	
22		1	89833619	
22		1	84007307	
22		1	89514311	
22		1	84000838	
22		1	84037964	
22		1	84041518	
23		1	89818830	
23		1	89835743	X
23		1	84022715	X
24		1	89835683	X
24		1	84036070	X

X - not in standard offer

„STOMIL SANOK” S.A.
Poland, 38-500 Sanok, ul. Reymonta 19



„STOMIL SANOK” S.A.
Poland, 38-500 Sanok, ul. Reymonta 19

